



MARINE ENVIRONMENT PROTECTION  
COMMITTEE  
54th session  
Agenda item 21

MEPC 54/21  
27 March 2006  
Original: ENGLISH

**REPORT OF THE MARINE ENVIRONMENT PROTECTION COMMITTEE  
ON ITS FIFTY-FOURTH SESSION**

<b>Section</b>	<b>Paragraph Nos.</b>	<b>Page No.</b>
1 INTRODUCTION	1.1 – 1.25	5
2 HARMFUL AQUATIC ORGANISMS IN BALLAST WATER	2.1 – 2.28	11
3 RECYCLING OF SHIPS	3.1 – 3.24	14
4 PREVENTION OF AIR POLLUTION FROM SHIPS	4.1 – 4.34	21
5 CONSIDERATION AND ADOPTION OF AMENDMENTS TO MANDATORY INSTRUMENTS	5.1 – 5.30	27
6 INTERPRETATIONS AND AMENDMENTS OF MARPOL 73/78 AND RELATED INSTRUMENTS	6.1 – 6.23	31
7 IMPLEMENTATION OF THE OPRC CONVENTION AND THE OPRC-HNS PROTOCOL AND RELEVANT CONFERENCE RESOLUTIONS	7.1 – 7.30	35
8 IDENTIFICATION AND PROTECTION OF SPECIAL AREAS AND PARTICULARLY SENSITIVE SEA AREAS	8.1 – 8.20	39
9 INADEQUACY OF RECEPTION FACILITIES	9.1 – 9.6	43
10 REPORTS OF SUB-COMMITTEES	10.1 – 10.45	44

<b>Section</b>	<b>Paragraph Nos.</b>	<b>Page No.</b>	
11	WORK OF OTHER BODIES	11.1 – 11.27	49
12	STATUS OF CONVENTIONS	12.1 – 12.3	55
13	HARMFUL ANTI-FOULING SYSTEMS FOR SHIPS	13.1 – 13.3	56
14	PROMOTION OF IMPLEMENTATION AND ENFORCEMENT OF MARPOL 73/78 AND RELATED INSTRUMENTS	14.1 – 14.8	57
15	FOLLOW-UP TO UNCED AND WSSD	15.1 – 15.2	60
16	TECHNICAL CO-OPERATION PROGRAMME	16.1 – 16.13	60
17	FUTURE ROLE OF FORMAL SAFETY ASSESSMENT AND HUMAN ELEMENT ISSUES	17.1 – 17.5	62
18	WORK PROGRAMME OF THE COMMITTEE AND SUBSIDIARY BODIES	18.1 – 18.10	63
19	APPLICATION OF THE COMMITTEES' GUIDELINES	19.1 – 19.7	65
20	ANY OTHER BUSINESS	20.1 – 20.11	66

### **LIST OF ANNEXES**

ANNEX 1	RESOLUTION MEPC.140(54) – GUIDELINES FOR APPROVAL AND OVERSIGHT OF PROTOTYPE BALLAST WATER TREATMENT TECHNOLOGY PROGRAMMES (G10)
ANNEX 2	RESOLUTION MEPC.141(54) – AMENDMENTS TO THE ANNEX OF THE PROTOCOL OF 1978 RELATING TO THE INTERNATIONAL CONVENTION FOR THE PREVENTION OF POLLUTION FROM SHIPS, 1973 (AMENDMENTS TO REGULATION 1, ADDITION TO REGULATION 12A, CONSEQUENTIAL AMENDMENTS TO THE IOPP CERTIFICATE AND AMENDMENTS TO REGULATION 21 OF THE REVISED ANNEX I OF MARPOL 73/78)
ANNEX 3	RESOLUTION MEPC.142(54) – AMENDMENTS TO THE GUIDELINES FOR THE APPLICATION OF THE REVISED MARPOL ANNEX I REQUIREMENTS TO FLOATING PRODUCTION, STORAGE AND OFFLOADING FACILITIES (FPSOs) AND FLOATING STORAGE UNITS (FSUs) (RESOLUTION MEPC.139(53))

- ANNEX 4 RESOLUTION MEPC.143(54) – AMENDMENTS TO THE ANNEX OF THE PROTOCOL OF 1978 RELATING TO THE INTERNATIONAL CONVENTION FOR THE PREVENTION OF POLLUTION FROM SHIPS, 1973 (ADDITION OF REGULATION 13 TO ANNEX IV OF MARPOL 73/78)
- ANNEX 5 RESOLUTION MEPC.144(54) – AMENDMENTS TO THE CODE FOR THE CONSTRUCTION AND EQUIPMENT OF SHIPS CARRYING DANGEROUS CHEMICALS IN BULK (BCH CODE)
- ANNEX 6 RESOLUTION MEPC.145(54) – EARLY AND EFFECTIVE APPLICATION OF THE 2006 AMENDMENTS TO THE CODE FOR THE CONSTRUCTION AND EQUIPMENT OF SHIPS CARRYING DANGEROUS CHEMICALS IN BULK (BCH CODE)
- ANNEX 7 UNIFIED INTERPRETATION TO REGULATION 12A OF THE REVISED MARPOL ANNEX I
- ANNEX 8 UNIFIED INTERPRETATION TO REGULATION 22.5 OF THE REVISED MARPOL ANNEX I
- ANNEX 9 RESOLUTION MEPC.146(54) – AMENDMENTS TO THE EXPLANATORY NOTES ON MATTERS RELATED TO THE ACCIDENTAL OIL OUTFLOW PERFORMANCE UNDER REGULATION 23 OF THE REVISED MARPOL ANNEX I
- ANNEX 10 PROPOSED AMENDMENTS TO THE REVISED ANNEX I OF MARPOL 73/78 (SOUTHERN SOUTH AFRICAN SEA AREA AS A SPECIAL AREA)
- ANNEX 11 UNIFORM FORMAT OF THE MEPC RESOLUTION FOR THE DESIGNATION OF PARTICULARLY SENSITIVE SEA AREAS
- ANNEX 12 GUIDANCE DOCUMENT FOR SUBMISSION OF PSSA PROPOSALS TO IMO
- ANNEX 13 PROPOSED AMENDMENTS TO ANNEX III OF MARPOL 73/78 (REVISED ANNEX III)
- ANNEX 14 TIMEFRAME LEADING TO THE ENTRY INTO FORCE OF THE AMENDED ANNEX III OF MARPOL 73/78
- ANNEX 15 PROPOSED AMENDMENTS TO THE CONDITION ASSESSMENT SCHEME (RESOLUTION MEPC.96(46), AS AMENDED)  
PROPOSED AMENDMENTS TO CAS (RESOLUTION MEPC.94(46), AS AMENDED)
- ANNEX 16 RESOLUTION MEPC.147(54) – GUIDELINES ON THE ASSESSMENT OF RESIDUAL FILLET WELD BETWEEN DECK PLATING AND LONGITUDINALS

- ANNEX 17      REVISED GUIDELINES FOR SYSTEMS FOR HANDLING OILY WASTES IN MACHINERY SPACES OF SHIPS INCORPORATING GUIDANCE NOTES FOR AN INTEGRATED BILGE WATER TREATMENT SYSTEM (IBTS)
- ANNEX 18      UNIFIED INTERPRETATION TO REGULATION 25A OF THE CURRENT MARPOL ANNEX I
- ANNEX 19      REVISED GUIDELINES FOR THE PROVISIONAL ASSESSMENT OF LIQUID SUBSTANCES TRANSPORTED IN BULK  
REVISED GUIDELINES FOR THE PROVISIONAL ASSESSMENT OF LIQUID SUBSTANCES TRANSPORTED IN BULK
- ANNEX 20      RESOLUTION MEPC.148(54) – REVISED GUIDELINES FOR THE TRANSPORT OF VEGETABLE OILS IN DEEPTANKS OR IN INDEPENDENT TANKS SPECIALLY DESIGNED FOR THE CARRIAGE OF SUCH VEGETABLE OILS IN GENERAL DRY CARGO SHIPS
- ANNEX 21      ITEMS TO BE INCLUDED IN THE AGENDAS OF MEPC 55, MEPC 56 AND MEPC 57

## 1 INTRODUCTION

1.1 The fifty-fourth session of the Marine Environment Protection Committee was held at IMO Headquarters from 20 to 24 March 2006 under the chairmanship of Mr. A. Chrysostomou (Cyprus).

1.2 The session was attended by delegations from the following 88 Members of IMO:

ALGERIA	JAMAICA
ANGOLA	JAPAN
ANTIGUA AND BARBUDA	KENYA
ARGENTINA	KUWAIT
AUSTRALIA	LATVIA
BAHAMAS	LIBERIA
BANGLADESH	LITHUANIA
BARBADOS	LUXEMBOURG
BELGIUM	MALAYSIA
BELIZE	MALTA
BOLIVIA	MARSHALL ISLANDS
BRAZIL	MAURITANIA
BULGARIA	MEXICO
CANADA	MOROCCO
CHILE	NETHERLANDS
CHINA	NEW ZEALAND
COLOMBIA	NIGERIA
CROATIA	NORWAY
CUBA	PAKISTAN
CYPRUS	PANAMA
DEMOCRATIC PEOPLE'S REPUBLIC OF KOREA	PERU
DEMOCRATIC REPUBLIC OF THE CONGO	PHILIPPINES
DENMARK	POLAND
DOMINICA	PORTUGAL
ECUADOR	QATAR
EGYPT	REPUBLIC OF KOREA
ESTONIA	ROMANIA
FINLAND	RUSSIAN FEDERATION
FRANCE	SAINT VINCENT AND THE GRENADINES
GABON	SAUDI ARABIA
GERMANY	SINGAPORE
GHANA	SLOVENIA
GREECE	SOUTH AFRICA
HONDURAS	SPAIN
ICELAND	SWEDEN
INDIA	SWITZERLAND
INDONESIA	THAILAND
IRAN (ISLAMIC REPUBLIC OF)	TRINIDAD AND TOBAGO
IRELAND	TUNISIA
ISRAEL	TURKEY
ITALY	TUVALU
	UKRAINE

UNITED KINGDOM  
UNITED STATES  
URUGUAY

VANUATU  
VENEZUELA

by representatives from the following Associate Member of IMO:

HONG KONG, CHINA

by representatives from the following United Nations and Specialized Agencies:

UNITED NATIONS (UN)  
UNITED NATIONS ENVIRONMENT PROGRAMME (UNEP)  
INTERNATIONAL LABOUR ORGANIZATION (ILO)

by observers from the following six intergovernmental organizations:

EUROPEAN COMMISSION (EC)  
INTERNATIONAL COUNCIL FOR THE EXPLORATION OF THE SEA (ICES)  
REGIONAL ORGANIZATION FOR THE PROTECTION OF THE MARINE  
ENVIRONMENT (ROPME)  
PORT MANAGEMENT ASSOCIATION OF EASTERN AND SOUTHERN AFRICA  
(PMAESA)  
SOUTH PACIFIC REGIONAL ENVIRONMENT PROGRAMME (SPREP)  
INTERNATIONAL MOBILE SATELLITE ORGANIZATION (IMSO)

and by observers from the following 29 non-governmental organizations:

INTERNATIONAL CHAMBER OF SHIPPING (ICS)  
INTERNATIONAL UNION OF MARINE INSURANCE (IUMI)  
INTERNATIONAL CONFEDERATION OF FREE TRADE UNIONS (ICFTU)  
INTERNATIONAL ASSOCIATION OF PORTS AND HARBORS (IAPH)  
BIMCO  
INTERNATIONAL ASSOCIATION OF CLASSIFICATION SOCIETIES (IACS)  
EUROPEAN CHEMICAL INDUSTRY COUNCIL (CEFIC)  
OIL COMPANIES INTERNATIONAL MARINE FORUM (OCIMF)  
FRIENDS OF THE EARTH INTERNATIONAL (FOEI)  
INTERNATIONAL ASSOCIATION OF THE INSTITUTES OF NAVIGATION (IAIN)  
INTERNATIONAL FEDERATION OF SHIPMASTERS' ASSOCIATIONS (IFSMA)  
COMMUNITY OF EUROPEAN SHIPYARDS' ASSOCIATIONS (CESA)  
INTERNATIONAL ASSOCIATION OF INDEPENDENT TANKER OWNERS  
(INTERTANKO)  
THE INTERNATIONAL TANKER OWNERS POLLUTION FEDERATION LTD  
(ITOPF)  
WORLD CONSERVATION UNION (IUCN)  
GREENPEACE INTERNATIONAL  
INTERNATIONAL ASSOCIATION OF DRY CARGO SHIPOWNERS  
(INTERCARGO)  
WORLD WIDE FUND FOR NATURE (WWF)

ASSOCIATION OF EUROPEAN MANUFACTURERS OF INTERNAL  
COMBUSTION ENGINES (EUROMOT)  
THE INSTITUTE OF MARINE ENGINEERING, SCIENCE AND TECHNOLOGY  
(IMarEST)  
INTERNATIONAL PARCEL TANKERS ASSOCIATION (IPTA)  
INTERNATIONAL SAILING FEDERATION (ISAF)  
THE INTERNATIONAL MARINE CONTRACTORS ASSOCIATION (IMCA)  
WORLD NUCLEAR TRANSPORT INSTITUTE (WNTI)  
INTERNATIONAL HARBOUR MASTERS' ASSOCIATION (IHMA)  
INTERNATIONAL BULK TERMINALS ASSOCIATION (IBTA)  
THE ROYAL INSTITUTION OF NAVAL ARCHITECTS (RINA)  
INTERFERRY  
INTERNATIONAL BUNKER INDUSTRY ASSOCIATION (IBIA)

1.3 The Chairman of the Maritime Safety Committee (MSC), Mr. I.M. Ponomarev (Russian Federation); the Chairman of the Sub-Committee on Bulk Liquids and Gases (BLG), Mr. Z. Alam (Singapore); and the Chairperson of the Sub-Committee on Dangerous Goods, Solid Cargoes and Containers (DSC), Mrs. O.P. Lefèvre (France), were also present.

#### **The Secretary-General's opening remarks**

1.4 In welcoming participants, the Secretary-General stated that, in many ways, the major issues in global shipping were the same as those that global society as a whole was currently facing and, like any other industry, shipping's environmental credentials were under sharper scrutiny than ever before as society came to terms with the understanding that this planet and its resources were not ours to do with as we chose. Shipping had to ensure that its activities were environmentally friendly and sustainable right from ship design, construction and equipment, through ship operation, to the final disposal of ships once their economic lives were over.

1.5 The Secretary-General stated further that IMO was determined to play its part in ensuring environmental sustainability, which was one of the eight Millennium Development Goals (MDGs) set by the 2000 Millennium Summit and re-affirmed at the 2005 World Summit. In this regard, he stated that the theme for this year's World Maritime Day would be "Technical Co-operation: IMO's response to the 2005 World Summit", with special emphasis on the maritime needs of Africa, which would give the Organization the opportunity to contribute, from its perspective, to the fulfilment of the MDGs. The international maritime community had a key role to play in meeting those Goals, by making use of the mechanisms it had at its disposal to promote economic development, which, in turn, would stimulate growth, foment job creation and generate an important source of invisible income in many developing countries. The Secretary-General referred also to the emphasis IMO was giving to the maritime needs of Africa, highlighting some large-scale programmes related to marine environment protection that would be carried out in the Gulf of Guinea, North Africa, West and Central Africa and the Western Indian Ocean sub-regions, in conjunction with several partners including the European Commission, GEF, IPIECA and REMPEC.

1.6 The Secretary-General noted that the work of the Organization in the current biennium regarding the marine environment would continue to focus principally on certain environmental issues, such as air pollution from ships, ship recycling and ballast water management, which, if left unattended, would have the potential to cause considerable damage to the atmosphere, health and the marine environment.

1.7 With regard to air pollution in general and greenhouse gas emissions in particular, the Secretary-General drew the attention of the Committee to the previous week's revelations by the World Meteorological Organization and the US National Oceanic and Atmospheric Administration that the atmosphere's gases associated with climate change were hitting record highs, which must be seriously addressed by all those concerned with the state of our planet.

1.8 The Secretary-General went on to say that shipping had, for many years, been considered as a clean and environmentally friendly mode of transport. However, as air pollution from land-based sources was being substantially reduced, there was increasing apprehension as to the pollution of the air caused by ships. Therefore, there was a clear urgency for the Committee to consider follow-up action to the IMO policies and practices related to the reduction of greenhouse gas emissions from ships, adopted by the last Assembly through resolution A.963(23). The Secretary-General wished the Committee success in devising and introducing achievable implementation measures as soon as practicable.

1.9 The Secretary-General said that, following the entry into force of MARPOL Annex VI in May 2005, the experience thus far gained in the implementation and enforcement of the Annex had demonstrated that there was a need to revise it, to take account of current technology and the imperative of further reducing air pollution from ships. The revision of Annex VI, with a target completion date of 2007, was a major task for the Committee during the current biennium. Since this work would necessitate expert advice from all sectors of the industry, Member States and observers were invited to ensure that expertise of the required depth was made available to the BLG Sub-Committee, which had been mandated to complete this task within a limited timeframe.

1.10 The Secretary-General noted that the issue of ship recycling had become a growing concern, not only from the environmental, but also from the occupational health and safety points of view, and that the Assembly, through resolution A.981(24), requested the Committee to develop a new mandatory instrument providing legally-binding and globally-applicable ship recycling regulations for international shipping and recycling facilities, in time for adoption in the 2008-2009 biennium. Since the item had been on the agenda of the Committee for some time, the Committee was at the forefront of the debate with the clear mandate to develop a pragmatic, workable, effective and well-balanced solution, taking into account the particular characteristics of world maritime transport and the need to ensure that ships reaching the end of their operational lives did so with maximum respect for the health of those involved, the safety of the ships concerned and the environment of the countries in which the recycling activities took place. The Secretary-General expressed his confidence that, for the lasting benefit of human and environmental health, the Committee would be able to achieve all these objectives.

1.11 The Secretary-General stated that the Organization would continue its close co-operation with ILO and the appropriate bodies of the Basel Convention so as not only to serve the purpose of this joint effort in the best interests of all the sides concerned, but also in order to avoid duplication of effort and overlapping of responsibilities and competencies among the three organizations.

1.12 In this connection, the Secretary-General informed that, as recommended by the Committee and the Technical Co-operation Committee and endorsed by the Council, an "International Ship Recycling Trust Fund" was being established to finance relevant technical co-operation activities for the benefit of all interested parties, especially the major ship-recycling countries.



1.13 Turning to the item on ballast water management, the Secretary-General highlighted the emphasis the international community placed on the issue of invasive species in ships' ballast water and the benefits to be derived from a globally agreed and standardized approach to it. Therefore, no effort should be spared to bring the 2004 Ballast Water Management Convention into force at the earliest possible date. The Secretary-General noted that, since MEPC 53, five more countries had become Party to the Convention, bringing the total number to six with an aggregate merchant shipping tonnage under their flag of 0.62%, against the required 30 countries representing 35% of the world total, and he hoped that many more countries would become Party to the Convention in the near future.

1.14 The Secretary-General noted that a GESAMP Ballast Water Working Group was recently established which, at its first meeting in January 2006, reviewed two proposals for the approval of Active Substances, and he was confident that the outcome of that meeting of the new Group would assist the Committee in taking forward its consideration of ballast water treatment technologies. In view of these positive developments, the Secretary-General invited Member States and observer organizations to provide IMO with the latest information on ballast water management technologies so as to allow for meaningful and fruitful deliberations during the second meeting of the Ballast Water Review Group.

1.15 Moving on to the proposed adoption of the Revised Guidelines for the Provisional Assessment of Liquid Substances Transported in Bulk, the Secretary-General noted that these Guidelines aimed at enabling Administrations of States producing mixtures of substances assessed by IMO to authorize manufacturers to carry out assessments of such mixtures on their behalf. Adoption of the Guidelines would be crucial for the Committee to respond to the challenge of putting in place all the prerequisites before the entry into force, on 1 January 2007, of the revised MARPOL Annex II and the amended IBC Code. In this regard, the Secretary-General considered the co-operation of all interested stakeholders in the full implementation of these two important IMO instruments to be of great importance, if the Committee was to ensure a level playing field in the international trade of bulk chemical products.

1.16 On the subject of PSSAs, the Secretary-General stated that the adoption by the last Assembly of the Revised Guidelines for the Identification and Designation of Particularly Sensitive Sea Areas was a crucial step in the on-going process of clarifying and strengthening the procedures for the establishment of such areas. Once the Committee had finalized, at this session, the review of the Guidance document for submission of PSSA proposals to IMO, proposals for new PSSAs would be considered in a more robust and consistent manner.

1.17 Regarding other important issues on the agenda of the Committee, the Secretary-General noted the proposed adoption of a new regulation on oil fuel tank protection; a further amendment to the definition of heavy grade of oil; and a new regulation on port State control on operational requirements under MARPOL Annex IV. The Secretary-General also noted the outcome of the work of the OPRC-HNS Technical Group, which had met the previous week to progress the finalization of the draft Manual on oil spill risk evaluation and assessment of response preparedness; the draft Guidance document on planning and response to chemical releases in the marine environment; the draft IMO/UNEP Guidance manual on the assessment and reinstatement of environmental damage following marine oil spills; and two introductory courses on preparedness for, and response to, HNS incidents.

1.18 With respect to the ratification and entry into force of IMO environment-related instruments, the Secretary-General was happy to inform the Committee that the 1996 Protocol to

the London Convention 1972 would enter into force on Friday, 24 March 2006, following Mexico's accession to it as its 26<sup>th</sup> party.

1.19 Notwithstanding that positive development, the Secretary-General remained concerned that, more than four years after its adoption, the number of States that had acceded to the 2001 AFS Convention was still not enough to bring it into force. The Secretary-General had accordingly written to Member States and now reiterated his invitation to all Governments that had not as yet done so, to give consideration to the ratification, acceptance, approval of, or accession to, the AFS Convention at the earliest possible opportunity.

1.20 The Secretary-General went on to state that the Voluntary IMO Member State Audit Scheme was widely anticipated as the catalyst in IMO's numerous, persistent and consistent attempts to eliminate sub-standard shipping. Following the previous year's decisions of the Council and Assembly, based on sound advice provided by the MSC, MEPC and TCC, the Scheme was ready for implementation and, to that end, the Secretary-General invited Member Governments to offer themselves for audit; nominate auditors to enable him to select audit teams from among them; and nominate qualified auditors for participate in the regional training courses planned by the Organization for the effective implementation of the Scheme. Having pledged his personal commitment to the Scheme, the Secretary-General informed the Committee that the Governments of Chile, Cyprus, Denmark, Egypt, Liberia, the Netherlands, Spain and the United Kingdom had notified the Organization of their preparedness to be audited and he looked forward to receiving many more offers of the same type in the near future.

1.21 Concerning the planned refurbishment of the Headquarters Building, which would be closed for approximately 12 months between the summers of 2006 and 2007, the Secretary-General informed that the Secretariat would move temporarily to other offices provided by the Host Government and the meetings of the Committees and Sub-Committees would be held elsewhere in London and abroad. He expressed the hope that delegates would be prepared to face, with resolute spirit and good humour, any discomfort and disruption from normal operations. The Secretary-General informed further that MEPC 55 would be held in London, at Central Hall Westminster, from 9 to 13 October 2006, as scheduled.

1.22 In closing his opening remarks, the Secretary-General stated that the maritime community as a whole would focus on the work of the Committee during that week for direction, guidance and assistance to all those concerned with the protection of the marine environment. He was confident that the Committee, under the Chairmanship of Mr. Chrysostomou, would reach sound decisions with the usual spirit of co-operation to serve well the cause of marine environmental protection and the interests of the world maritime community at large.

### **Chairman's remark**

1.23 In responding, the Chairman thanked the Secretary-General for his remarks and advice and stated that they would be given every consideration in the work of the Committee.

### **Adoption of the agenda**

1.24 The Committee adopted the agenda (MEPC 54/1) and the provisional timetable for guidance during the session (MEPC 54/1/1, annex 2, as amended). The agenda, as adopted, with a list of documents considered under each agenda item, is set out in document MEPC 54/INF.8.

## **Credentials**

1.25 The Committee noted the report of the Secretary-General that credentials of the delegations were in due and proper order.

## **2 HARMFUL AQUATIC ORGANISMS IN BALLAST WATER**

2.1 The Committee noted that, to date, six countries (Maldives, Nigeria, Saint Kitts and Nevis, Spain, the Syrian Arab Republic and Tuvalu) had ratified or acceded to the Ballast Water Management Convention, becoming Contracting States. The Committee urged Member States to give consideration to the ratification, acceptance, approval of, or accession to, the BWM Convention at the earliest possible opportunity.

2.2 The Committee recalled that, according to the updated programme for the development of the remaining guidelines, further work under this agenda item should be undertaken by relevant Sub-Committees, leaving policy matters and adoption of various Guidelines to the Committee itself. The Committee agreed to consider the policy aspects submitted at this session in the plenary and to refer the proposals for further development of the Guidelines to the Ballast Water Working Group to be established at BLG 10.

### **Further work on the remaining guidelines for uniform implementation of the Ballast Water Management Convention**

2.3 The Committee recalled that MEPC 53 adopted five Guidelines relating to ballast water management and instructed BLG and FSI Sub-Committees to continue to develop the remaining guidelines as indicated in an updated programme.

2.4 The Committee, having considered documents MEPC 54/2/6 and MEPC 54/2/7, mainly relating to the Guidelines under development by the BLG Sub-Committee, decided to refer the comments provided on Guidelines (G2), (G11), (G13) and (G7) to BLG 10 for further consideration by the Ballast Water Working Group and invited Brazil to provide draft text for the suggested amendments. Furthermore the Committee did not agree with the proposed changes to Guidelines (G10).

2.5 In this connection, the delegation of Brazil thanked the Committee for the opportunity to hold an informal consultation meeting concerning documents MEPC 54/2/6 and MEPC 54/2/7. The delegation expressed its intention to request BLG 10 to consider the two documents further.

### **Adoption of the Guidelines (G10)**

2.6 The Committee recalled that, at its 4th intersessional meeting, the Ballast Water Working Group completed the work on the Guidelines for approval and oversight of prototype ballast water treatment technology programmes (G10) and that MEPC 53 agreed to consider the final draft (MEPC 53/WP.1, annex 2), together with a draft MEPC resolution, at this session with a view to adoption. In the absence of further comments regarding the final draft, the Committee adopted the above Guidelines by resolution MEPC.140(54) as set out at annex 1.

### **Report of the first meeting of the GESAMP-BWWG**

2.7 The Committee noted that following the instruction by MEPC 53, the Secretariat worked together with the GESAMP Inter-Secretariat and established the GESAMP-Ballast Water

Working Group (GESAMP-BWWG) to review the proposals for approval of ballast water management systems that make use of Active Substances. The Committee further noted that the Group held its first meeting from the 23 to 27 January 2006 and reviewed two proposals submitted by Germany and the Republic of Korea.

2.8 Having considered the report of the first meeting of the GESAMP-BWWG (MEPC 54/2/12), the Committee endorsed the recommendation of the Group and agreed to give Basic Approval to both proposals (i.e. Paraclean Ocean by Germany and Electro Clean System by the Republic of Korea). With a view to minimising risks to ship, crew and the environment, the Committee invited the flag State Administrations involved to authorize on-board testing only when the concerns identified in annexes 5 and 6 of the Group's report had been addressed to their complete satisfaction.

2.9 Germany thanked the Secretariat for the effort to establish the GESAMP-BWWG in such a short period of time and expressed its appreciation to the Group, in particular to its Chairman Mr. Finn Pedersen, for the work done.

2.10 IUCN was of the view that information on 'by and end-products' together with their interactive effects should not be treated as confidential after basic approval is given and expressed some concern regarding the completeness of the dossiers submitted to GESAMP-BWWG. IUCN noted further that 'by and end-products' and their interactive effects were not included in the 'Risk Characterization' chapter of document MEPC 54/2/1 (European Commission) and suggested that their inclusion be considered.

### **Methodology for information gathering and the conduct of work**

2.11 The Committee noted that in the limited time available, the GESAMP-BWWG initiated the development of the 'Methodology for information gathering and the conduct of work' (MEPC 54/2/12, annex 4) taking into consideration the provisions of the BWM Convention, Procedure (G9) and the Technical guidance on data requirements, principles of risk assessment and documentation contained in document MEPC 54/2/1 (European Commission).

2.12 The Committee noted the usefulness of a generic Emission Scenario Document (ESD) for ballast water discharges and invited Members and observers to explore the possibility of developing such a document.

2.13 The Committee requested the GESAMP-BWWG to continue to develop the Methodology during its next meeting, taking into account the comments made in plenary.

2.14 The Committee noted the concern regarding acute toxicity at discharge and the short-term effects of the treated ballast water on the environment expressed by Japan and its intention to submit a paper on this particular aspect to MEPC 55.

2.15 The Committee noted the comments made by the United States and supported by Norway regarding the need to follow the recently adopted Procedure (G9) and to avoid introducing new requirements in excess to provisions of the Procedure. In this respect, the delegation of the United States expressed concern regarding the use of a document that was not discussed beforehand in the Committee as a basis for the development of the 'Methodology for information gathering and conduct of work' and recommended that further consideration be given to the draft Methodology at MEPC 55.

2.16 The Committee agreed to invite Members and observers to submit further comments on the draft Methodology before 21 April 2006 to allow GESAMP-BWWG to address such comments during its second meeting.

2.17 The Committee, having considered document MEPC 54/2/1 introduced by the European Commission, noted some differences between the technical guidance suggested and the provisions of Procedure (G9) and decided to request the GESAMP-BWWG to further consider this document, so as to identify inconsistencies with Procedure (G9) and advise the Committee accordingly at MEPC 55.

2.18 The Committee, having considered documents MEPC 54/2/2 (European Commission) and MEPC 54/2/11 (Republic of Korea), agreed that further clarification of consequences for applicants and on the possibility of using data waivers may be needed. The Committee invited further comments on these aspects from Members and observers before 21 April 2006 and requested the GESAMP-BWWG to provide expert advice on this matter to MEPC 55.

2.19 The Committee, having considered document MEPC 54/2/8 introduced by the United Kingdom on behalf of the EU countries and the European Commission and document MEPC 54/2/10 by CEFIC providing supplementary information on the risk-benefit analysis, agreed in principle with the concept and decided to request BLG 10 to further consider these documents and assess the need to develop a methodology for conducting risk-benefit analysis for ballast water discharges. In this respect, the Committee also agreed to invite delegations that have conducted ballast water discharges risk-benefit analysis, Formal Safety Assessments related to ballast water management or other risk related activities, to share such information in pursuance of Article 6 of the BWM Convention.

#### **Future work relating to ballast water**

2.20 The Committee recalled that MEPC 53, having considered the recommendations of the Review Group, agreed to conduct a further review of technologies in accordance with regulation D-5 of the Convention during MEPC 55.

2.21 The Committee recalled that MEPC 53 also invited submissions on possible options should the review at MEPC 55 indicate that the anticipated progress had not been achieved. In this respect the Committee considered document MEPC 54/2/4 (International Chamber of Shipping) containing a proposal to put back by one year the first D-2 standard application date (i.e. 1 January 2009), should the outcome of the review at MEPC 55 indicate that sufficient progress in the development and approval of the technology had not been achieved. In view of the wide support for the suggested way forward, the Committee agreed to endorse the proposal in principle. The Committee invited Members and observers to provide statistical information on manufacturing and installation capacity for treatment equipment for consideration at MEPC 55.

2.22 The Committee noted the submission by Japan (MEPC 54/2/9) containing the intention of Japan to propose Basic Approval for three Ballast Water Management systems that made use of Active Substances and the suggested time schedule for the second meeting of the GESAMP-BWWG.

2.23 Having noted the information provided by the Secretariat and the time schedule proposed in annex 2 of document MEPC 54/2/12 (Secretariat), the Committee agreed that, assuming all conditions were met, the GESAMP-BWWG should aim to hold its meetings five months before

MEPC sessions and could consider two or maximum three dossiers in the chronological order of their submission. In this respect, the Committee urged Members to submit the non-confidential description of their Ballast Water Management systems that made use of Active Substances to the MEPC session before the one expected to decide on the Basic Approval or, if this was not possible, at their earliest opportunity after that, but not later than the 28-week deadline established for the submission of the proposal for approval (dossier) for revision by the GESAMP-BWWG.

2.24 On an exceptional basis, the Committee agreed to invite Members to submit their proposals for approval (application dossiers) and the non-confidential description of the systems for MEPC 55, by Friday, 21 April 2006, at the latest to allow some preparation time for the second meeting of GESAMP-BWWG to be held in May/June 2006.

### **Other information relating to ballast water management**

2.25 The Committee, having considered document MEPC 54/2/5 introduced by the United Kingdom, noted the support for the proposed Guidelines concerning ballast water exchange in Antarctic waters and the intention of some delegations to provide their comments directly to the United Kingdom delegation and invited Members and observers to enhance regional co-operation and communicate relevant information in pursuance of Articles 13 and 14 of the BWM Convention.

2.26 The Committee noted the information provided by Germany (MEPC 54/INF.3) regarding a ballast water sampling device, which may be used during in-line sampling for type approval requirements as well as for compliance control.

2.27 The Committee noted the information provided by Sweden (MEPC 54/INF.6) regarding the intention of Sweden to submit a proposal for approval of a ballast water management system that used Active Substances and a brief description of the technologies used.

### **Recommendation to facilitate the work of the Review Group**

2.28 Having considered the recommendations for the conduct of the review of the status of the ballast water management technologies provided by Secretariat (MEPC 54/WP.5), the Committee encouraged Members and observers to provide the latest information on ballast water management technologies so as to ensure meaningful and fruitful deliberations during the second meeting of the Ballast Water Review Group at MEPC 55 and invited Members to submit the relevant information, using both the format recommended in document MEPC 53/2/2 and the matrix contained in the annex to document MEPC 54/WP.5, with a view to facilitating the work of the Review Group.

## **3 RECYCLING OF SHIPS**

3.1 The Committee recalled that at its 53rd session it established a Working Group on Ship Recycling as a result of which the Committee:

- .1 approved the draft Assembly resolution on the development of a new IMO instrument on ship recycling, for submission to the twenty-fourth session of the Assembly for adoption;

- .2 approved the draft Assembly resolution on the adoption of the amendments to the IMO Guidelines on Ship Recycling (resolution A.962(23)), for submission to the twenty-fourth session of the Assembly for adoption;
- .3 approved the draft MEPC circular on the Implementation of the IMO Guidelines on Ship Recycling - "Gas-free-for-hot-work" certification, which was circulated as MEPC/Circ.466; and
- .4 endorsed the outcome of the intersessional meeting of the Working Group on Ship Recycling as the starting point for the development of the new IMO instrument on ship recycling.

3.2 The Committee further recalled that the 24th session of the Assembly noted the work of the MEPC concerning ship recycling, and adopted the two Assembly resolutions: resolution A.980(24) on the "Amendments to the IMO Guidelines on Ship Recycling"; and resolution A.981(24) on the "New Legally-binding Instrument on Ship Recycling".

3.3 The Committee noted that the Assembly endorsed the view that the development of a new legally-binding instrument on ship recycling should not shift the attention of stakeholders away from implementation of the current IMO Guidelines on Ship Recycling adopted by resolution A.962(23) and amended by resolution A.980(24).

3.4 The Committee finally recalled that the second session of the Joint ILO/IMO/BC Working Group on Ship Scrapping was hosted by the Basel Convention in Geneva from 12 to 14 December 2005 and that the Joint Working Group agreed to a number of recommendations in relation to the work programme and activities of ILO, IMO and the Conference of Parties to the Basel Convention with regard to ship recycling issues, for consideration by the three Organizations, as appropriate.

### **Planning of the work**

3.5 The Committee agreed to consider first the proposed draft for the new legally-binding instrument on recycling of ships together with documents commenting on the proposed draft and on related issues; then to consider the two submissions containing initial proposals on Guidelines; then to consider the report on the second session of the Joint ILO/IMO/BC Working Group; and finally, to instruct the Working Group as appropriate.

### **Consideration of the proposed draft for a new legally-binding instrument on recycling of ships**

3.6 The Committee noted that the Assembly, by resolution A.981(24), requested the Committee to develop a new legally-binding instrument on ship recycling to be ready for adoption in the 2008-2009 biennium.

3.7 In introducing document MEPC 54/3 Norway proposed that the draft legally-binding instrument contained in the annex to its document be used by the Committee as the base document for the further development of the legally-binding instrument. Norway also highlighted the main thrust and key elements of the draft convention by providing regulations for:

- .1 the design, construction, operation and preparation of ships so as to facilitate safe and environmentally sound recycling, without compromising the safety and operational efficiency of ships;
- .2 the operation of ship recycling facilities in a safe and environmentally sound manner; and
- .3 the establishment of an appropriate enforcement mechanism for ship recycling.

3.8 The Committee thanked Norway and those delegations that submitted comments documents on the draft legally-binding instrument: MEPC 54/3/4 by Brazil, MEPC 54/3/5/Rev.1 by Greenpeace International, MEPC 54/3/8 by the Secretariat of the Basel Convention, MEPC 54/3/9 by India, MEPC 54/3/10 by the International Labour Office, and MEPC 54/3/11 by ICS, BIMCO, INTERTANKO, INTERCARGO, IPTA and WNTI. The Committee also noted the two submissions related to the draft legally-binding instrument: MEPC 54/3/1 by Japan, and MEPC 54/3/3 by IACS.

3.9 In the ensuing discussion a large number of delegations took the floor, all supporting the Organization's action to develop a mandatory instrument on ship recycling and expressing appreciation to Norway for providing a first draft of such an instrument. All delegations that spoke stated that they would participate actively in the Working Group.

3.10 In summing up, the Chairman stated that the Norwegian document (MEPC 54/3) should be used by the Working Group as a basis to further develop the draft convention, taking into account all comments made in plenary and all documents commenting on the Norwegian draft.

3.11 Regarding the need for further co-operation between IMO, ILO and the Basel Convention, the Chairman stated that, as requested by Assembly resolution A.981(24), the Committee would continue co-operating with ILO and the Basel Convention on the subject of ship recycling.

### **Consideration of initial proposals on associated guidelines under the proposed legally-binding instrument**

3.12 The Committee noted that Germany, in document MEPC 54/3/6, provided a first draft for a structure of the Guidelines for the development of the Inventory of Hazardous Materials as part of the Draft International Convention for the safe and environmentally sound recycling of ships. Because of their close interrelation, a first draft of the structure of the Guidelines for survey and certification was also enclosed.

3.13 The Committee also noted that Japan, in document MEPC 54/3/7, proposed a basis for common survey and inspection guidelines for verifying conformity with the Inventory, as called for in annex 2 of document MEPC 54/3 submitted by Norway and containing its proposal for the draft legally-binding instrument.

3.14 The Committee considered whether the proposal by Germany (MEPC 54/3/6) might form part of the legally-binding instrument instead of a separate guideline. The Committee instructed the Working Group to consider this issue and report back to the plenary.

3.15 The Committee also considered whether the proposal by Japan (MEPC 54/3/7) should be developed as a guideline under the legally-binding instrument when the draft instrument had



become more mature. The Committee instructed the Working Group to consider the issue and report back to the plenary.

### **Report of the Second Session of the Joint ILO/IMO/BC Working Group on Ship Scrapping**

3.16 The Committee noted that IMO maintained close co-operation with ILO and the Basel Convention on the issue of ship recycling, and that the Joint ILO/IMO/Basel Convention Working Group on Ship Scrapping was evidence of this co-operation.

3.17 The Committee recalled that the overall task set by the three Organizations for the Joint Working Group was to act as a platform for consultation, co-ordination and co-operation in relation to their work programmes and activities with regard to issues related to ship recycling. The Committee further recalled that the aims of the Joint Working Group were to promote a co-ordinated approach to the relevant aspects of ship recycling, to avoid duplication of work and overlapping of roles responsibilities and competencies between the three Organizations, and to identify any further needs.

3.18 The Committee, having considered document MEPC 54/3/2 on the report of the second session of the Joint ILO/IMO/BC Working Group on ship scrapping, hosted by the Basel Convention in Geneva from 12 to 14 December 2005 under the chairmanship of Mr. Roy Watkinson (United Kingdom), decided as follows on the 14 action points of the document and instructed the Working Group on Ship Recycling to take them into account as appropriate:

- .1 the Committee noted that the Joint Working Group continued to use the interim Rules of Procedure agreed at its first session;
- .2 the Committee noted the discussions, outcome and information in the report of the Joint Working Group on the proposed new legally-binding instrument on ship recycling submitted by Norway to MEPC 54 which had also been submitted to the Joint Working Group as document ILO/IMO/BC WG 2/INF.1. The Committee further noted that the Joint Working Group had welcomed IMO's decision to develop a legally-binding instrument on ship recycling;
- .3 the Committee noted the views expressed at the Joint Working Group on the issue of promotion of the implementation of the Guidelines on ship scrapping;
- .4 the Committee considered the Joint Working Group's view that the analysis and recommendations given in the report of the intersessional Working Group on the comparison of the guidelines of the ILO, IMO and BC on ship scrapping (ILO/IMO/BC WG 2/6) be taken into account, as appropriate, in the development at the IMO of the mandatory requirements on the recycling of ships;
- .5 the Committee noted the views, in general, of the Joint Working Group as regards Joint Technical Co-operation activities and, in particular, considered and agreed to its recommendation that each Organization invite the other two Organizations to participate in workshops or seminars organized by the Organization;
- .6 the Committee considered and agreed to the Joint Working Group's recommendation that each Organization includes in the programme of its activities a section providing information on the Guidelines of the other two Organizations;

- .7 the Committee considered and agreed to the Joint Working Group's recommendation that the secretariats of the three Organizations make efforts to enhance co-ordination and co-operation in the organizations of such activities;
- .8 the Committee considered the view of the Joint Working Group on the subject of abandonment of ships on land or in ports and agreed that the outcome of the consideration of this issue by other bodies be considered by the Group. In this respect, the Committee noted that the IMO Legal Committee would discuss the issue of abandonment at its 91st session in April 2006; the outcome of LEG 91 on the matter would be brought to the attention of MEPC 55;
- .9 the Committee considered the view by the Joint Working Group, with respect to the paper on Environmentally Sound Management (ILO/IMO/BC/WG 2/8), that the concepts embodied in that document could provide useful input to the IMO process to develop a mandatory instrument for ship recycling. The Committee noted the discussions, outcome and information in the report of the Joint Working Group and instructed the Working Group to take these into account as appropriate;
- .10 the Committee considered the Joint Working Group's agreement that any reporting system developed at the IMO for the purposes of ship recycling should take into account the specific circumstances of ship recycling and have regard to the objectives to be met by such reporting, e.g. to ensure scrapping is conducted in an environmentally sound manner. The Committee noted the Joint Working Group's agreement and instructed the Working Group to take this into account as appropriate;
- .11 the Committee considered the Joint Working Group's recommendation that experience of prior informed consent, as established under the Basel Convention and other existing reporting systems, be considered in the development at the IMO of a reporting system as part of a mandatory instrument for ship recycling. The Committee noted the above and, following some discussion, instructed the Working Group to further consider reporting systems, taking into account relevant experience gained under the Basel Convention as well as other existing international reporting systems;
- .12 the Committee noted the views of the Joint Working Group on pre-cleaning and preparation of ships and its role in sustainable ship scrapping operations and instructed the Working Group to take these into account as appropriate;
- .13 the Committee noted the Joint Working Group's views in considering the issue of a future meeting of the Group and requested the Working Group to consider this issue and make recommendations to the plenary of the Committee; and
- .14 the Committee noted the Joint Working Group's views as regards its objectives and future work programme and requested the Working Group to consider this issue and make recommendations to the plenary of the Committee.

### **Establishment of the Working Group**

3.19 The Committee re-established the Working Group on Ship Recycling under the chairmanship of Mr. Jens Koefoed (Norway), with the following Terms of Reference:

Taking into consideration submissions by Members and comments made in Plenary, the Working Group on Ship Recycling is instructed to:

- .1 further develop the text of the draft legally-binding instrument for the safe and environmentally sound recycling of ships on the basis of document MEPC 54/3 (Norway), taking into account comments made during plenary and proposals in documents: MEPC 54/3/4 (Brazil), MEPC 54/3/5/Rev.1 (Greenpeace International), MEPC 54/3/8 (Secretariat of the Basel Convention), MEPC 54/3/9 (India), MEPC 54/3/10 (ILO), MEPC 54/3/11 (ICS and co-sponsoring industry Associations), MEPC 54/3/1 (Japan), MEPC 54/3/3 (IACS) and MEPC 54/3/2 (Report of the second session of the Joint ILO/IMO/BC Working Group on Ship Scrapping); including, if possible, reaching an agreement in principle on the lay-out and main thrust of the draft legally-binding instrument;
- .2 consider whether the proposal contained in document MEPC 54/3/6 by Germany should form part of the legally-binding instrument or be developed as a separate guideline and consider the proposal contained in document MEPC 54/3/7 by Japan and any possible implications for the draft legally-binding instrument;
- .3 further consider reporting systems, taking into account experience of prior informed consent as established under the Basel Convention as well as other existing international reporting systems;
- .4 consider action items .13 and .14 of paragraph 4 of document MEPC 54/3/2; and make recommendations to the plenary of the Committee;
- .5 develop a work plan for the further development of the draft legally-binding instrument;
- .6 consider the need for an intersessional correspondence group and, if agreed, develop draft Terms of Reference for such a group; and
- .7 submit a written report to plenary on Thursday, 23 March 2006.

### **Report of the Working Group on Ship Recycling**

3.20 The Working Group on Ship Recycling met from 20 to 23 March 2006. The report of the Group had been presented to the Committee as document MEPC 54/WP.6.

3.21 The Chairman of the Group introduced the Group's report and advised the Committee that the Group had agreed to include the following addition to Article 3 of the draft instrument: "(4) This Convention shall not apply to any ships of less than [...]."

3.22 The Committee approved the report of the Group in general and, in particular:

- .1 noted the discussions and draft amendments of the draft instrument as set out in annex 1 and paragraphs 4 to 29 of document MEPC 54/WP.6;

in connection to Article 3(2) of the draft instrument and paragraph 10 of the Group's report, the Committee was reminded that Singapore had supported the position of the United States;

in connection to the timetable for implementing regulation B-I-4 to existing ships, IACS requested that the Committee give careful consideration to this issue, since serious difficulties could be expected if existing ships had to comply with the requirements of draft regulation B-I-4(1) by the first safety construction renewal survey after the entry into force of the Convention, as stated in draft regulation B-I-4(2);

- .2 concurred with the Working Group's approach on the development of guidelines for Inventory of Hazardous Materials, as set out in paragraphs 30 to 32 of document MEPC 54/WP.6;
- .3 noted the discussions of the Working Group on the reporting systems and the draft amendments to Section D, as set out in paragraphs 33 and 34 and Section D of annex 1 of document MEPC 54/WP.6;
- .4 noted the Working Group's views on the possible need for a future meeting of the Joint ILO/IMO/BC Working Group, as set out in paragraph 35 of document MEPC 54/WP.6;
- .5 noted the following provisional work plan for the development of the new instrument on recycling of ships:

CG	Report by 10 July 2006	Amend first draft of Instrument and List of Guidelines.
MEPC 55 WG	October 2006	Second draft of Instrument and draft of some Guidelines. Discuss possible involvement of other IMO bodies. Discuss the 3 <sup>rd</sup> JWG ILO/IMO/BC.
[CG]		Amend the second draft of Instrument and continue with the Guidelines.
[ISWG]	July 2007	Third draft of Instrument and continue with Guidelines.
MEPC 56 WG	July 2007	Consider third draft and advise on the holding of a Conference.
25 <sup>th</sup> Assembly	December 2007	Assembly decides on the holding of a diplomatic Conference.

- .6 agreed to having an intersessional Correspondence Group on Ship Recycling<sup>1</sup> and to its draft terms of reference as set out below, and noted the invitation from the Working Group that all interested parties take part in the work of the Correspondence Group:
- 6.1 further develop the draft legally-binding instrument, including Sections A, B and D of its Annex, based on the discussions and the report of the Working Group on Ship Recycling established at MEPC 54;
  - 6.2 develop Section C of the Annex of the draft legally-binding instrument, on the basis of document MEPC 54/3, maintaining the layout contained in the document, and taking into consideration relevant comments and other inputs received;
  - 6.3 develop a provisional list of guidelines necessary under the draft legally-binding instrument; and
  - 6.4 submit a written report to MEPC 55.

3.23 Malta stated that the development of the draft instrument, including the issue of reporting systems, should be based on principles already agreed at previous sessions of the Committee. Malta stated further that if had certain reservations regarding the speed of development of the draft instrument.

3.24 Many delegations thanked Norway for providing a first draft of the legal instrument and also thanked the Chairman of the Working Group for the progress achieved during this session.

#### **4 PREVENTION OF AIR POLLUTION FROM SHIPS**

##### **Entry into force of MARPOL Annex VI**

4.1 The Committee noted that MARPOL Annex VI, Regulations for the Prevention of Air Pollution from Ships, entered into force on 19 May 2005. The Committee also noted that as per 9 February 2006, the Protocol of 1997 to MARPOL 73/78 (Annex VI) had 30 Parties, representing approximately 63.73% of the gross tonnage of the world's merchant shipping.

##### **Review of MARPOL Annex VI and the NO<sub>x</sub> Technical Code**

4.2 The Committee recalled further that it was widely acknowledged by scientists and marine engine manufacturers that different technology improvements now existed that would enable significant improvement over the existing standards found in MARPOL Annex VI.

---

<sup>1</sup> **Co-ordinator:**  
Mr. Sveinung Oftedal  
Address:  
P.O. Box 8123 Dep.,  
N-0032 Oslo,  
Norway  
Tel: +47 22 45 44 10  
E-mail: sveinung.oftedal@sjofartsdir.no

4.3 The Committee also recalled that MEPC 53 agreed to a general review of MARPOL Annex VI and the NO<sub>x</sub> Technical Code and approved the Terms of Reference for the revision work to be undertaken by the BLG Sub-Committee with a target completion date of 2007.

4.4 The Committee considered documents MEPC 54/4 by Hong Kong, China and MEPC 54/4/9 by India, and agreed that the Unified Interpretation to regulation 16(9) of MARPOL Annex VI, approved by MEPC 53 and circulated by MEPC.1/Circ.473, should not be amended. However, the Committee also agreed that there might be a need to restrict the use of shipboard incinerators installed prior to January 2000 inside ports, harbours and estuaries, and instructed the Working Group on Air Pollution to consider the issue further.

#### **Standardization of on-shore power supply**

4.5 The Committee considered documents MEPC 54/4/3 by Germany and Sweden and MEPC 54/4/10 by Friends of the Earth International regarding standardization of onshore power supply connections and the justification for this. The Committee agreed that standardized power supply connections could benefit the industry but that further studies were needed before any decision could be made. The Committee noted the information provided by the International Association of Ports and Harbors (IAPH) regarding ongoing standardization work: a meeting on the subject with the industry was deferred until after MEPC 54 so that IMO would be able to reach a conclusion and IAPH offered to co-operate with IMO on further work. The Committee also noted the view of the delegation from Venezuela to involve the IAPH, and in particular the Inter-American Commission of Ports, as the appropriate forums. The Committee further noted the ongoing work in the International Standardization Organization (ISO) related to onshore power supply. The Committee instructed the Secretariat to liaise with relevant international and intergovernmental organizations and report back to the Committee at the next session.

#### **Wash water discharge criteria**

4.6 The Committee considered document MEPC 54/4/6 by Sweden regarding waste streams from existing inert gas scrubbers installed in tankers and the connection with the Guidelines for on-board exhaust gas SO<sub>x</sub> cleaning systems adopted by resolution MEPC.130(53).

4.7 The Committee recalled that the Guidelines for Exhaust Gas SO<sub>x</sub> Cleaning Systems (EGCS-SO<sub>x</sub>) state that waste streams from such equipment shall not be discharged into enclosed ports unless it can be documented that there is no adverse impact on the ecosystems in such waters.

4.8 The Committee recalled also that MEPC 53 agreed that more specific recommendations and criteria relevant to EGCS-SO<sub>x</sub> wash-water discharges should be developed in the near future and that Members were invited to submit information to MEPC 54. The Committee noted that no information was submitted to this session but that several Members gave information about ongoing trials and developments and that this information on the outcome would be submitted to the next session. The Committee therefore agreed to extend the invitation and revisit the issue at the next session.

4.9 The Committee agreed to refer the following documents to BLG 10 as they were directly related to the revision of Annex VI and NO<sub>x</sub> Technical Code:

- .1 MEPC 54/4/4 (the Republic of Korea) on suitable NO<sub>x</sub> emission test cycle for propeller-law-operated engine equipped with variable-pitch propeller; and

- .2 MEPC 54/4/6 (Sweden) on Waste Streams from inert gas scrubbers in existing tankers.

### **Amendments to the Survey Guidelines under the Harmonized System of Survey and Certification**

4.10 The Committee considered document MEPC 54/4/11 by INTERTANKO covering a proposal for further improvements to the amendments to the revised Survey Guidelines under the Harmonized System of Survey and Certification (HSSC) for the purpose of MARPOL Annex VI adopted by resolution MEPC.128(53).

4.11 In this connection, the Committee noted that the amendments to MARPOL Annex VI on the introduction of the Harmonized System of Survey and Certification (HSSC) were expected to enter into force on 22 November 2006. Recognizing that the Guidelines were adopted only seven months ago at MEPC 53, the Committee agreed that it would be premature to consider further amendments until the ongoing revision work of MARPOL Annex VI and the NOx Technical Code was finalized.

4.12 The Committee agreed to refer the document (MEPC 54/4/11) to BLG to be considered in connection with the ongoing revision of MARPOL Annex VI and the NOx Technical Code.

### **Progress of the revision of MARPOL Annex VI and the NOx Technical Code**

4.13 The Committee acknowledged the complexity and technical nature of the revision of MARPOL Annex VI and the NOx Technical Code, and the large numbers of documents to be considered by the BLG Sub-Committee at its next session in April 2006. The Chairman invited the Committee to consider how it would be possible for the BLG Sub-Committee to meet the target completion date of 2007 or if this date should be postponed, and proposed to come back to the discussion when considering the report of the Working Group on Air Pollution.

### **Implementation of MARPOL Annex VI**

#### **Bunker delivery documents**

4.14 The Committee considered document MEPC 53/4/1 by the Secretariat, which recalled that MARPOL Annex VI, by regulation 18, placed requirements on ship owners in respect of bunker delivery notes and representative samples of the fuel received. The Committee further recalled that MEPC 47, by resolution MEPC.96(47), adopted Guidelines for the Sampling of Fuel Oil for Determination of Compliance with Annex VI of MARPOL 73/78.

4.15 The Committee noted the concern expressed by several Members on problems relating to ships that cannot obtain the appropriate documentation from bunker suppliers located in ports of both Parties and non-Parties to the 1997 Protocol (Annex VI).

4.16 The Committee further noted that the Secretariat, since the entry into force of MARPOL Annex VI, had received numerous enquiries from fuel oil suppliers, port authorities, shipping companies, individual ship officers, ship agents and other stakeholders in the maritime industry, relating to interpretation and understanding of regulation 18 of Annex VI and resolution MEPC.96(47) with regard to the issuing of bunker delivery notes and the obtaining of a representative fuel oil sample to be provided to the receiving ship in connection with a bunker

operation. The Committee considered that the answers to most of the enquiries raised could be found in the texts of regulation 18 of MARPOL Annex VI and resolution MEPC.96(47).

4.17 The Committee agreed that there was an urgent need to raise awareness on the necessity to enhance implementation and enforcement of regulation 18 of Annex VI, and to urge Member States to request fuel oil suppliers to comply with the requirements of regulation 18 of MARPOL Annex VI and resolution MEPC.96(47).

4.18 The Committee agreed further to issue an MEPC Circular addressing the matter and instructed the Working Group on Air Pollution to develop a draft MEPC circular for consideration and adoption.

### **Notification to IMO on VOCs regulations in Ports and Terminals**

4.19 The Committee recalled that regulation 15(4) of MARPOL Annex VI requested the Organization to circulate, for information, a list of the ports and terminals designated by Parties to the Protocol of 1997 for the regulation of VOCs emissions from tankers, to other Parties to the Protocol and Member States of the Organization. To that effect, MEPC 42 agreed to issue MEPC/Circ.345 (19 November 1998) on Notification to the Organization on Ports and Terminals where Volatile Organic Compounds (VOCs) Emissions are to be regulated.

4.20 The Committee noted the information provided by the Secretariat in document MEPC 54/4/8, that only one Party to the Protocol of 1997 had so far notified the Organization of VOC regulations in place in their ports and terminals.

4.21 The Committee agreed that it was essential for tanker operators and others involved in design or operation of vessels applicable to such regulations, to be adequately informed of the different national and local VOCs requirements.

4.22 The Committee agreed to urge Parties to the Protocol of 1997 and other Member States to notify the Organization of any such VOCs requirements already in place or planned to be introduced, and instructed the Working Group on Air Pollution to draft an MEPC circular to that effect for consideration by the Committee.

### **Greenhouse gas emissions from ships**

#### **Ship CO<sub>2</sub> emission indexing**

4.23 The Committee recalled that MEPC 53 approved the MEPC circular on the Interim Guidelines for Voluntary Ship CO<sub>2</sub> Emission Indexing for Use in Trials, circulated as MEPC/Circ.471, by which industries, organizations and interested Administrations were invited to promote the use of the Interim Guidelines and report their experience back to MEPC.

4.24 The Committee noted the information submitted on trials by India (MEPC 54/4/5 and MEPC 54/4/5/Add.1). The Committee agreed that it was premature to revise the Guidelines at this stage and further noted that the Guidelines state that such revision should take place at or after MEPC 58, in order to gain as much as possible practical experience to provide a better foundation for an update.



## **GHG Policy**

4.25 The Committee recalled that, following the request by MEPC 42, there had been ongoing co-operation between the Secretariats of IMO and UNFCCC and its Subsidiary Body for Scientific and Technical Advice (SBSTA) on the reduction of greenhouse gas emissions from ships and the use of bunker fuel oils in recognition of the Kyoto Protocol requirements.

4.26 The Committee noted that the Secretariat reported the outcome of MEPC 53 to the meeting of the Parties to the Kyoto Protocol held in Canada in November 2005. However, due to time constraint, the meeting was not able to conclude its discussions regarding emissions from international bunkers. It was expected that the next meeting in Bonn in May 2006 would consider the matter further. The outcome of the SBSTA Meeting would be reported to MEPC 55.

4.27 The Committee recalled that the Assembly, by resolution 963(23), adopted “IMO Policies and Practices related to the Reduction of Greenhouse Gas Emissions from Ships”. In the resolution, the Assembly urged MEPC to undertake further work to identify and develop the necessary mechanisms needed to achieve limitation or reduction of GHG emissions from ships.

4.28 The Committee noted that climate change caused by greenhouse gas emissions from burning of fossil fuel was a steadily growing concern for many countries and that scientists were finding more and more proof of the damage caused by greenhouse gases. Many Governments were considering how best to address the matter at the local, national and international levels.

4.29 The Committee agreed that there was a need to co-operate with other relevant UN bodies in considering the matter.

4.30 The Committee considered documents MEPC 54/4/2 (United Kingdom) and MEPC 54/4 (Norway) on the follow-up to resolution A.963(23).

4.31 The Committee had an extensive debate on the matter, and taking into account paragraphs 1 and 2 of resolution A.963(23), noted that only paragraph 1(b) had been dealt with when MEPC 53 approved the Interim Guidelines for Voluntary Ship CO<sub>2</sub> Emission Indexing for Use in Trials. The Committee agreed that further action needed to be considered in response to the Assembly resolution by identifying the mechanism or mechanisms needed to achieve the possible limitation or reduction of GHG emissions from international shipping.

## **Establishment of the Working Group**

4.32 Following the debate, the Committee re-established the Working Group on Air Pollution with the following Terms of Reference:

- “1 Taking into consideration submissions by Members and comments made in Plenary, the Working Group on Air Pollution is instructed to:
- .1 consider documents MEPC 54/4, MEPC 54/4/9, and their relevance to the ongoing revision of MARPOL Annex VI and the NO<sub>x</sub> Technical Code and propose relevant instructions to the BLG Sub-Committee during the revision of MARPOL Annex VI and the NO<sub>x</sub> Technical Code;

- .2 consider the information given by the Secretariat in document MEPC 54/4/1 regarding documentation of fuel oil quality and prepare an MEPC circular on the matter; and
  - .3 consider the information given by the Secretariat in document MEPC 54/4/8 regarding the Member States' obligation in accordance with regulation 15 of MARPOL Annex VI about different national VOCs requirements, and propose how best to get Members to fulfil their obligations and prepare an MEPC circular on the matter, recognizing that MARPOL Annex VI has entered into force.
- 2 Taking into consideration paragraphs (1) and (2) of resolution A.963(23) from technological and methodological perspectives:
- .1 consider the need to develop an MEPC Circular on the promotion of the use of the "Interim Guidelines for Voluntary Ship CO<sub>2</sub> Emission for Use in Trials", in trials;
  - .2 consider the issue of limitation or reduction of GHG emissions from ships and develop a draft framework and a work plan with timetable, on how the Committee can identify and develop mechanism or mechanisms to limit or reduce GHG emissions from ships. The framework referred to above shall be flexible enough to allow the Committee to evaluate solutions which are technical, operational and or market-based; and
  - .3 consider the issue of a GHG emission baseline and provide advice to the Committee.
- 3 Consider the need to establish a Correspondence Group to progress the matter of GHG emission from ships, and if appropriate, draft Terms of Reference for the Group.
- 4 Present a written report to Plenary for the Terms of Reference 1.1.1 to 1.1.3 on Thursday, 23 March 2006. Written report for the rest of the Terms of Reference should be submitted in the form of Working Group Chairman's report to MEPC 55."

### **Report of the Working Group on Air Pollution**

4.33 Having received the report of the Working Group (MEPC 54/WP.7/Rev.1) regarding the work undertaken in accordance with the Terms of Reference in paragraphs 1.1.1 to 1.1.3, the Committee approved the report in general and, in particular:

- .1 the draft MEPC circular on Bunker delivery note and fuel oil sampling, as set out in annex 1 of document MEPC 54/WP.7/Rev.1 and instructed the Secretariat to issue them as MEPC/Circ.508; and
- .2 the draft MEPC circular on Notification to the organization on ports or terminals where volatile organic compounds (VOCs) emissions are to be regulated, as set out in annex 2 of document MEPC 54/WP.7/Rev.1 and instructed the Secretariat to issue them as MEPC/Circ.509.

4.34 The Committee noted the oral report by the Chairman of the Working Group regarding the progress made on the tasks given in paragraphs 2 and 3 of the Terms of Reference of the Group and noted that a written report would be submitted in the form of a report by the Chairman of the Group to MEPC 55. The Committee noted in particular that the Group had agreed to a “Draft Work Plan to Identify and Develop the Mechanisms Needed to Achieve the Limitation or Reduction of GHG Emission from International Shipping”, which would be an annex to the report by the Chairman of the Group for consideration by MEPC 55.

## **5 CONSIDERATION AND ADOPTION OF AMENDMENTS TO MANDATORY INSTRUMENTS**

### **Proposed amendments to the revised MARPOL Annex I**

5.1 The Committee recalled that MEPC 53 (18 to 22 July 2005) considered and approved amendments to the revised MARPOL Annex I with a view to adoption at the present session (MEPC 53/24, paragraphs 10.4, 10.5 and annex 25). The proposed amendments were circulated by the Secretary-General of the Organization, in accordance with Article 16(2)(a) of the MARPOL Convention, under cover of Circular letter No.2657 of 1 August 2005.

5.2 The Committee considered document MEPC 54/5 (Secretariat) providing the text of the proposed amendments to the revised MARPOL Annex I as follows: new proposed regulation 13A on oil fuel tank protection, consequential amendments to the IOPP Certificate and amendments to regulation 21 relating to the definition of Heavy Grade Oil. The Committee noted that the text of a draft MEPC resolution on adoption of the amendments was also provided in annex to document MEPC 54/5.

5.3 The Committee noted that the Secretariat was also suggesting, in document MEPC 54/5, to split the proposed new regulation 13A, as approved by MEPC 53, in two, so that part of it would become paragraph 28.9 in regulation 1 (Definitions) in order to keep consistency with the layout of the revised Annex I where definitions of ship age groups are placed together in regulation 1 instead of being scattered across many different regulations. The Committee endorsed this suggestion.

5.4 The Committee had before it three documents commenting on the proposed amendments to the revised MARPOL Annex I: MEPC 54/5/3 (International Association of Drilling Contractors (IADC)); MEPC 54/5/4 (IACS); and MEPC 54/5/6 (IACS).

5.5 The Committee noted that IADC, in document MEPC 54/5/3, expressed concern that, under the present text of the proposed new regulation 13A, the regulation would apply to column-stabilized mobile offshore drilling units (MODUs) which, by their special hull forms, could not comply with the required protection distance of fuel tanks from the outer shell. IADC was proposing amendments to the proposed regulation or appropriate guidance, in this respect.

5.6 The Committee noted also that IACS, in document MEPC 54/5/4, suggested that, as regards the application of proposed regulation 13A to Floating Production Storage and Offloading units (FPSOs) and Floating Storage Units (FSUs), only side protection (not double bottom) was needed for oil fuel tanks in these specialized vessels to keep consistency with related requirements in current MARPOL Annex I regulation 22(1) and (2) on damage assumptions, as recommended for FPSOs and FSUs in MEPC/Circ.406 as updated by MEPC.139(53).

5.7 On a different concern by IACS in document MEPC 54/5/4, the Committee agreed that the revised MARPOL Annex I regulation 37.4 on prompt access to computerised shore-based stability and residual strength calculation programmes should also apply to FPSOs and FSUs. However, on a related issue, the Committee decided that the conversion from an existing oil tanker into an FPSO or an FSU should not be excluded from the requirements of the proposed new regulation 13A.

5.8 The Committee noted further that IACS, in document MEPC 54/5/6, was seeking clarification on some possible ambiguities in the proposed regulation 13A such as: meaning of “Capacity”; definition of “C”; definition of “oil fuel tank” and definition of “minimum oil outflow”. The Committee tasked the Drafting Group on mandatory amendments to carry out the necessary clarification on this issue.

5.9 Following debate, the Committee agreed to refer the proposed amendments to the revised MARPOL Annex I and the draft MEPC resolution on their adoption to the drafting group for review, taking into account comments made in plenary and proposals provided in documents MEPC 54/5/3, MEPC 54/5/4 and MEPC 54/5/6.

#### **Proposed amendments to MARPOL Annex IV**

5.10 The Committee recalled that MEPC 53 (18 to 22 July 2005) considered and approved amendments to MARPOL Annex IV with a view to adoption at the present session (MEPC 53/24, paragraph 6.2 and annex 17). The proposed amendments were circulated by the Secretary-General of the Organization, in accordance with Article 16(2)(a) of MARPOL 73/78, under cover of Circular letter No.2657 of 1 August 2005.

5.11 The Committee noted document MEPC 54/5/1 (Secretariat) with the text of the proposed amendments and draft MEPC resolution on their adoption. The Committee noted also that the proposed amendments were to add a new regulation 13 concerning port State control on operational requirements under MARPOL Annex IV.

5.12 The Committee noted also document MEPC 54/5/5 (India) with a proposal to amend regulation 13 of the revised MARPOL Annex I by including the term “offshore terminals” as an additional location where port State inspections may take place. Following debate, the Committee tasked the drafting group with reviewing this matter.

5.13 The Committee agreed to refer the proposed amendments to MARPOL Annex IV to the drafting group for review.

#### **Proposed amendments to the Code for the construction and equipment of ships carrying dangerous chemicals in bulk (BCH Code)**

5.14 The Committee noted that the BCH Code was a mandatory requirement under MARPOL Annex II and the proposed amendments were consequent to the revised MARPOL Annex II and the amended IBC Code which were expected to enter into force on 1 January 2007.

5.15 The Committee noted also that MEPC 53 considered and approved the amendments to BCH Code (MEPC 53/24, paragraph 10.59 and annex 28) the text of which were circulated by the Secretary-General of the Organization, in accordance with article 16(2)(a) of MARPOL 73/78, under cover of Circular letter No. 2661 of 1 August 2005 with a view to adoption at MEPC 54.

5.16 The Committee noted further that, in accordance with the time frame in the draft resolution as mandated by article 16 of the MARPOL Convention, the date of formal entry into force of the proposed BCH amendments (1 August 2007) would not coincide with the entry into force of the revised MARPOL Annex II and the amended IBC Code (1 January 2007). The Committee recognized that this could result in certain confusion, for example, as it related to the issuance of BCH Certificates of Fitness.

5.17 Following discussion, the Committee decided that the drafting group should address this matter and invited delegations to send members who had been involved in the preparation of the BCH amendments to participate in the drafting group.

### **Establishment of the drafting group**

5.18 The Committee agreed to establish a drafting group on MARPOL amendments and instructed it, taking into account written submissions as well as decisions, comments and proposals made in plenary, to:

- .1 review and finalize the texts of amendments, including any additional amendments to other related instruments, as necessary, to the revised MARPOL Annex I (new regulation 13A, consequential amendments to the IOPP Certificate Supplement and amendments to regulation 21) and to MARPOL Annex IV (new regulation 13) as well as the text of the associated MEPC resolutions on their adoption;
- .2 review and finalize the text of amendments to the BCH Code as well as the text of the associated MEPC resolution on their adoption;
- .3 prepare a resolution for the early application of the BCH amendments; and
- .4 submit a report to the plenary for consideration and adoption of the amendments to MARPOL 73/78 and the BCH Code by the Committee on Thursday, 23 March 2006.

### **Outcome of the drafting group**

5.19 The Committee considered the report of the drafting group on MARPOL amendments (MEPC 54/WP.8) which met on 21 and 22 March 2006 under the chairmanship of Mr. Hendrik Bruhns (Germany) and noted the following main modifications, clarifications and editorial adjustments as proposed by the group.

### **Change of number of the new regulation on oil fuel tank protection**

5.20 The Committee noted that the drafting group, taking into account that number 13A in the proposed new regulation might cause confusion, once the revised Annex I was in force, with the "old" regulations 13A to 13H in the current Annex I, had agreed to change its number to 12A and that, in taking this decision, the group had taken into account that the new regulation was a construction requirement for all ships and, as such, should be included in Chapter 3 of the revised Annex I.

### **Application of proposed regulation 12A to Submersible Drilling Units**

5.21 The Committee noted that the drafting group, in order to address the concerns of IADC in paragraph 5.5 above, had recognized that the requirements of paragraph 8 of draft regulation 12A were in alignment with respective MARPOL Annex I regulations for oil carried in bulk and required a side double hull width of over 1.5 m only if more than 20,000 tons of fuel were carried. Consequently, it had been considered by the group that this was not a realistic value for MODUs so that the concerns regarding the penetration depth of IADC were well addressed by the proposed new regulation as written. The Committee noted also that other concerns of IADC regarding the damage penetration assumptions for the hull form of column stabilized MODUs had been addressed by the drafting group by means of a draft Unified Interpretation.

### **Proposed amendments to the Guidelines for the application of the revised MARPOL Annex I requirements to FPSOs and FSUs**

5.22 The Committee noted that the drafting group had recognized that the most adequate way of addressing the issues affecting FPSOs and FSUs in the proposed new regulation 12A was by amending the Guidelines for the application of the revised MARPOL Annex I requirements to FPSOs and FSUs, adopted by resolution MEPC.139(53), and that the amendments would refer to the application of regulation 12A to FPSOs and FSUs excluding the requirements of paragraph 6. However, the drafting group had concluded that, when undertaking any voyage away from the operating station for whatever purpose, the double bottom oil fuel tanks were to be empty unless they were in compliance with the requirements of paragraph 6.

5.23 The Committee noted further that the drafting group had also developed proposed amendments to the Guidelines to the effect that regulation 37.4 of the revised MARPOL Annex I applied to FPSOs and FSUs, as well as proposed amendments to the IOPP Certificate Supplement for FPSOs and FSUs, as set out in annex 2 to the Guidelines, to take into account the inapplication of paragraph 6 of proposed regulation 12A.

### **Conversion of an existing oil tanker into an FPSO or an FSU**

5.24 The Committee noted that the drafting group, in considering the Committee's previous decision on this issue, as referred to in paragraph 5.7 above, had recognized that whilst existing oil tankers being converted into FPSOs or FSUs would have to comply with the side protection requirements for oil fuel tank in the new regulation 12A, they, nevertheless, would not be subject to the double hull requirements of regulation 21 (regulation 13F of the current Annex I) for cargo oil tanks. The Committee noted also that the drafting group had developed a draft text, for consideration by the Committee, recommending application of the requirements of regulation 12A to FPSOs and FSUs excluding the requirements of paragraph 6 to new, purpose built FPSOs and FSUs only.

5.25 The Committee endorsed the views of the drafting group concerning conversion of an existing oil tanker into an FPSO or FSU and agreed to include appropriate text in the amendments to the Guidelines for the application of the revised MARPOL Annex I requirements to FPSOs and FSUs referred to in paragraph 5.28.2 below.

### **Amendments to MARPOL Annex IV**

5.26 The Committee noted that the drafting group had recognized that only MARPOL Annexes I and VI mentioned offshore terminals as an additional location where port State control

on operational requirements was carried out whilst Annexes II, III, IV and V did not. The Committee further noted that the drafting group, following extensive debate, had agreed to include offshore terminals in the proposed new regulation 13 of MARPOL Annex IV.

### **Amendments to the BCH Code**

5.27 The Committee noted minor editorial changes to the proposed amendments introduced by the drafting group, as well as the latter's view that it was highly desirable for the provisions of the BCH Code, which were mandatory under MARPOL 73/78 and recommendatory from a safety standpoint, to remain identical when adopted by the MEPC and the MSC. In this regard, the drafting group had developed a draft MEPC resolution for the early and effective implementation of the BCH Code amendments, taking into consideration the link with the expected entry into force date of the amended IBC Code (1 January 2007).

### **Adoption of the amendments**

5.28 Having agreed to the above modifications and proposals, the Committee endorsed other minor editorial changes carried out by the drafting group, approved the report in general and, subsequently, adopted:

- .1 amendments to the revised MARPOL Annex I (amendments to regulation 1, addition of regulation 12A, consequential amendments to the IOPP Certificate, and amendments to regulation 21) by resolution MEPC.141(54), set out in annex 2;
- .2 amendments to the Guidelines for the application of the revised MARPOL Annex I requirements to FPSOs and FSUs by resolution MEPC.142(54), set out in annex 3;
- .3 amendments to the revised MARPOL Annex IV (addition of regulation 13) by resolution MEPC.143(54), set out in annex 4;
- .4 amendments to the BCH Code by resolution MEPC.144(54), set out in annex 5;
- .5 resolution MEPC.145(54) on the Early and Effective Application of the 2006 amendments to the BCH Code, set out in annex 6.

5.29 Having resolved the above, the Committee approved a Unified Interpretation to regulation 12A of the revised MARPOL Annex I to column stabilized MODUs, set out in annex 7.

5.30 The Committee agreed to bring the amendments to the BCH Code, adopted by resolution MEPC.144(54), to the attention of the MSC for action as appropriate.

## **6 INTERPRETATIONS AND AMENDMENTS OF MARPOL 73/78 AND RELATED INSTRUMENTS**

### **Proposed amendment to regulation 15 of the revised MARPOL Annex I**

6.1 In document MEPC 54/6/4, Norway invited the Committee to enhance environmental protection in the Antarctic Sea by introducing a ban on the carriage of heavy grade oil (HGO), as

defined in regulation 21 of the revised MARPOL Annex I (13H of current Annex I), as cargo or as fuel. Norway proposed the following amendment to regulation 15.4 of the revised MARPOL Annex I:

“In respect of the Antarctic area, *any use and carriage of heavy grade oil as defined in regulation 21 and* any discharge into the sea of oil or oily mixtures from any ship shall be prohibited.”

6.2 The delegations who spoke supported the intent of the Norwegian proposal to give the Antarctic Sea extra protection from the risk of HGO discharges and spillages. However, most of these delegations raised concerns and questioned whether the proposed actions suggested by Norway were the appropriate ones and in particular cautioned about the implications of the proposed amendment to regulation 15.4, as follows:

- .1 the operation of Search and Rescue vessels in the Antarctic Sea might need to be exempted from this prohibition;
- .2 would this ban also apply to all fishing vessels active in the Antarctic Sea?;
- .3 the definitions under regulation 21 applied to the carriage of HGO in oil tankers only, while the proposed amendment was aimed at all ships;
- .4 the relevant Sub-Committees (DE or BLG) should be consulted on the precise formulation of the amendment; and
- .5 as this was the first time that the question of total prohibition of use and carriage of HGO within any sea area had been brought to the Committee’s attention, such a proposal should be examined carefully.

6.3 The Committee agreed with the thrust of the Norwegian proposal and invited Norway to submit a revised proposal to a future session of the BLG Sub-Committee for consideration, taking into account the comments received at this session. The Committee would then review the issue after having received the report of the BLG Sub-Committee.

### **Unified Interpretation to regulation 22.5 of the revised MARPOL Annex I**

6.4 The Committee recalled that this issue was dealt with by MEPC 53 following a submission by IACS in document MEPC 53/6/2 seeking clarification on issues associated with the application of regulation 22 (pump-room bottom protection) of the revised MARPOL Annex I. IACS expressed the opinion that the requirements applied to cargo and ballast pump-rooms and that ballast piping (which must be located in the double bottoms as they could not be located in cargo tanks as per regulation 13F) was permitted to be located within the required pump-room double bottom, provided any damage to that piping did not render the ship’s pumps (ballast and cargo) ineffective.

6.5 The Committee recalled also that MEPC 53 concurred with this opinion and agreed that it would be desirable to develop a Unified Interpretation at its next session. In this respect, IACS undertook to submit a suitable proposal to MEPC 54 (MEPC 53/24, paragraph 6.14).

6.6 The Committee noted that, in document MEPC 54/6/3, IACS was proposing the text of a draft Unified Interpretation of regulation 22.5 of the revised MARPOL Annex I to the effect that



the term “pump room” should be meant to include ballast and/or cargo-rooms and ballast piping should be permitted to be located within the pump-room double bottom, provided any damage to that piping did not render the ship’s pumps (ballast and cargo) ineffective.

6.7 The Committee noted also that INTERTANKO, in document MEPC 54/6/5, disagreed with the assertion that the term “pump-rooms” should include “ballast pump-rooms” for the purpose of regulation 22. In their view, ballast pump-rooms need not be protected by the double bottom and the placing of ballast pumps above the double bottom would entail a loss in suction power and stripping capability. INTERTANKO suggested that the term “pump-room” should include only “cargo pump-room”.

6.8 All delegations that spoke supported the proposal of IACS for the draft Unified Interpretation of regulation 22.5, as amended by INTERTANKO.

6.9 In response to the request of IACS for clarification in its document MEPC 54/6/3, paragraph 9, the delegation of Australia expressed the view that the double bottom protection for pump-rooms located outside of the cargo tank length should be limited to a tank which does not carry oil.

6.10 Reflecting on the comments received at this session, IACS submitted a further developed text, as follows:

“The term “*pump-room*” means a cargo pump-room. Ballast piping is permitted to be located within the pump-room double bottom provided any damage to that piping does not render the ship’s pumps located in the “*pump-room*” ineffective.

The double bottom protecting the “*pump-room*” can be a void tank, a ballast tank or, unless prohibited by other regulations, a fuel oil tank.”

6.11 The Committee approved the revised Unified Interpretation, as set out in annex 8, and instructed the Secretariat to include this new Unified Interpretation to regulation 22.5 of the revised MARPOL Annex I in the MARPOL consolidated edition currently being prepared.

### **Impact of the entry into force of the revised MARPOL Annex I upon the IOPP Certificate**

6.12 The Committee noted that upon the expected entry into force of the revised MARPOL Annex I on 1 January 2007, the world’s merchant fleet would still be carrying IOPP Certificates, and supplements, issued under the “old” or current MARPOL Annex I. A possible conflict might develop when port State control officers checked the validity of IOPP Certificates issued under the “old” MARPOL Annex I after 1 January 2007.

6.13 The Committee noted further that IACS, in considering the impact of the new requirements under the revised MARPOL Annex I, had identified the need for clarification of the necessity to re-issue the IOPP Certificate and supplements on 1 January 2007. IACS’ opinion, in document MEPC 54/6/2, was that re-issuing all IOPP certificates and supplements on the expected entry into force date of the revised MARPOL Annex I for the world fleet, regardless of the expiry date of existing certificates, would be meaningless and place an undue administrative burden on Administrations and recognized organizations.

6.14 The Committee agreed that, unless the documentation is required to be re-issued as a consequence of a ship having to comply with any new requirements in the revised MARPOL

Annex I, IOPP Certificates and supplements in effect at the time of entry into force of the revised MARPOL Annex I should be accepted, particularly by port State control officers, until the expiry date of the associated IOPP Certificate, at which time a new Supplement complying with the new requirements under the revised MARPOL Annex I would be issued for attachment to the renewed IOPP Certificate. The Committee thanked IACS for bringing this issue to its attention.

6.15 The Committee instructed the Secretariat to prepare and issue an MEPC circular (MEPC/Circ.513) conveying the Committee's decision to Member Governments and Parties to MARPOL 73/78.

### **Amendments to the Explanatory Notes on Accidental Oil Outflow Performance**

6.16 The Committee recalled that the Explanatory Notes on matters related to the accidental oil outflow performance under regulation 23 of the revised MARPOL Annex I were adopted by resolution MEPC.122(52) to provide explanations and interpretations on the uniform application of the said regulation.

6.17 The Committee reviewed document MEPC 54/6 by Germany proposing the deletion of paragraph 6.3 of part B, entitled "Guidance on individual regulations", of the Explanatory Notes, on the grounds that the mean outflow for bottom damage should be calculated for one side of the ship only because the probability that the damage would extend into the transverse zone bounded by  $Y_P$  and  $Y_S$  was the same whether the centre of damage was located to the starboard side or to the port side. The delegation had also prepared a draft MEPC resolution on adoption of the amendment.

6.18 The Committee adopted resolution MEPC.146(54) on Amendments to the Explanatory Notes on matters related to the accidental oil outflow performance under regulation 23 of the revised MARPOL Annex I, set out at annex 9 to this report. The Committee thanked the delegation of Germany for the work carried out.

### **Harmonized implementation of the Revised Guidelines and Specifications for Pollution Prevention Equipment for Machinery Space Bilges of Ships**

6.19 The Committee recalled that the Revised Guidelines and Specifications for Pollution Prevention Equipment for Machinery Space Bilges of Ships were adopted by resolution MEPC.107(49) and came into effect on 1 January 2005.

6.20 The Committee considered document MEPC 54/6/1/Rev.1 by Germany proposing the issuance of an MEPC Circular seeking clarification on several issues where the procedure for type approval, as described in the Revised Guidelines, was vague and different interpretations of the Guidelines were possible.

6.21 The Committee noted that the annex to the proposed MEPC circular provided a harmonized interpretation of the requirements of the Revised Guidelines set out in paragraphs 4.1.5 (on the definition of the term "normal duty"), 1.2.9.6 – Part 1 – (on computing the time during interruptions of the test of the 15ppm bilge separator), paragraph 3.2.2.3 – Part 3 – (on the humidity test) and the diagram in the appendix to Appendix 1 (on computing interruption time).

6.22 The delegation of Japan indicated that it supported the German proposal for the guidance note on paragraph 4.1.5 of resolution MEPC.107(49). However, the delegation disagreed with

the proposed guidance note on paragraph 1.2.9.6 in part 1 of the annex to this resolution, allowing some interruptions in the operation of 15 ppm bilge separators in specific circumstances. Under no circumstances would Japan accept interruptions in the operation of these separators.

6.23 Upon the proposal of some delegations, the Committee agreed to refer the proposal by Germany to the DE Sub-Committee for further consideration (see paragraph 14.4). The Committee would then review a further developed proposal.

## **7 IMPLEMENTATION OF THE OPRC CONVENTION AND THE OPRC-HNS PROTOCOL AND RELEVANT CONFERENCE RESOLUTIONS**

### **General**

7.1 The Committee noted that the fourth session of the OPRC-HNS Technical Group was held from 13 to 17 March 2006 under the Chairmanship of Mr. Ezio Amato (Italy).

7.2 In introducing the report of the Technical Group (MEPC 54/WP.1), the Chairman stated that the OPRC-HNS Technical Group had made considerable progress on its work programme. He then presented the main outcome of the fourth Technical Group meeting, which is summarized in the following paragraphs.

### **Manuals and guidance documents**

7.3 The Committee, having noted the progress made on the **Manual on oil spill risk evaluation and assessment of response preparedness**, approved the re-establishment of a correspondence group to work intersessionally and instructed it to produce a finalized draft of the manual for submission to TG 5 (MEPC 54/WP.1, paragraphs 3.2 to 3.8).

7.4 The delegation of the Russian Federation, in noting the progress of the Group in finalizing the manual, emphasized its importance as a key to planning for oil spills at all levels and noted that the finalized version should take into account considerations such as the volume of oil carried as well as the risk from terrorist activities.

7.5 The Committee, in considering the draft **Guidance document on planning and response to chemical releases in the marine environment** worked out during the fourth session of the Technical Group, noted that several delegations had circulated the document to their respective relevant national counterparts for review and, based on the feedback received, had observed that the current draft was an excellent document covering all the major subjects in a clear and understandable way that would be very useful to end users without any further modification.

7.6 Consequently, the Committee agreed to the draft text as final and, having noted that the guidance document still required the addition of photos and graphics, entrusted the Secretariat to format and edit the document; to work with IPIECA to finalize the selection of photos and graphics in the intersessional period; and to submit the finalized document to MEPC 55 for formal approval (MEPC 54/WP.1, paragraphs 3.9 to 3.12).

7.7 The Committee welcomed the attendance of UNEP at the Technical Group's fourth session as well as its intention to fully participate in the work of the Technical Group to finalize the **IMO/UNEP Manual on the assessment and restoration of environmental damage following marine oil spills**.

7.8 In noting the progress in the development of the manual, the Committee concurred with the recommendation of the Group that it be developed as a pragmatic guide based on sound scientific principles that takes into account the existing international compensation regime, rather than the more strategic document originally considered (MEPC 54/WP.1, paragraphs 3.13 to 3.17).

7.9 The Committee considered the discussions of the Group with regard to the review of the **Manual on oil pollution – Section V: Administrative aspects of oil pollution response**, which emphasized several priority areas for the review including: the need to verify the referencing of IMO instruments within the manual; a substantial rewrite of part I, chapter 7 on salvage; a rewrite of part II on liability and compensation to ensure it was current, taking into account recent modifications to the international compensation regime; an expanded section addressing OPRC-related issues, recognizing its importance within the context of the manual; and a review of the reference section and the addition of new references to the existing list (MEPC 54/WP.1, paragraphs 3.18 to 3.23).

7.10 Subsequently, the Committee approved the course of action proposed by the Technical Group for the review and update of the Manual on oil pollution – Section V: Administrative aspects of oil pollution response (MEPC 54/WP.1, paragraphs 3.18 to 3.23).

7.11 The Committee noted the information provided with regard to a **list of IMO technical publications related to OPRC and HNS** and, taking into account the suggestion of the Technical Group that this would be a useful list to retain as a standing item on its agenda to be considered during its future meetings, approved the addition of this item to the work programme of the Group (MEPC 54/WP.1, paragraphs 3.24 to 3.27).

## **Training**

7.12 The Committee took note of the progress made in the development of **two IMO training courses on the Introduction to preparedness and response for HNS incidents** and also noted the specific suggestions made for further developing the course including the need to: shift the emphasis of the courses to better reflect a planning and preparedness approach rather than a hands-on response approach; develop a stand-alone section on safety; to include information and training on modelling and the various modelling tools available; and to familiarize participants with proper HNS response terminology, so that they are able access the necessary assistance, equipment and other response resources in the event of an HNS incident (MEPC 54/WP.1, paragraphs 4.2 to 4.8).

7.13 The Committee considered the various comments received on the current version of the **OPRC Train-the-Trainer course**, which revealed that the course took a very academic approach emphasizing primarily the pedagogical aspects of training, but with only limited linkages to the OPRC model training courses, for which it was developed. The Committee also noted the suggestions regarding the need to consider e-learning options for the delivery of future courses and recognized the importance of different approaches for the delivery of training in different areas of the world, taking into account cultural variance.

7.14 Subsequently, the Committee approved the revision of the OPRC Train-the-Trainer course, recognizing that the present version is out of date and is too complex to meet the needs of most developing countries (MEPC 54/WP.1, paragraphs 4.9 to 4.15).

7.15 Further to the discussions that took place during the meeting of the Technical Group, the Committee recognized the need for a **standardized briefing package for oil spill response** that could be used to brief senior executives on critical issues of high-level interest when managing a major oil spill response, rather than the more specific technical considerations. The Committee further considered the recommendation that the package should be aimed at government staff and others who may need to brief their own senior officials in order to provide education on the real issues related to responding to marine oil spills and provide the necessary 'reality checks' on the limitations involved.

7.16 The Committee, in noting the information provided, instructed the Secretariat to collect and analyse available materials on the structure and content of briefings to senior officials during oil spills, with a view to the possible development of a standardized briefing package on oil spill response for senior managers and executives, and requested the Secretariat to submit this information to TG 5 for further consideration (MEPC 54/WP.1, paragraphs 4.16 to 4.23).

### **Information services and exchange**

7.17 The Committee approved the information and structure of a **website providing information and assistance for HNS incidents** developed by the Group and, having made some amendments at the request of the delegation of China, instructed the Secretariat to take the necessary steps to convert the information to an appropriate format for inclusion in the IMO website (MEPC 54/WP.1, paragraphs 5.2 to 5.4 and annex 1).

7.18 The Committee was made aware of the implementation of an **IMO web page providing information on preparedness and response to marine oil spills** now activated on the IMO website (MEPC 54/WP.1, paragraphs 5.5 and 5.6).

### **Co-operation with other organizations**

7.19 Having taken into account the progress made by the IMO and UNEP Secretariats in planning and organizing the **2006 IMO/UNEP Forum on regional co-operation in combating marine pollution** that is scheduled to take place from 2 to 5 May 2006 at IMO Headquarters, the Committee noted that the Forum was expected to become an ongoing programmatic activity of both IMO and UNEP to continue to jointly promote and enhance regional co-operation in combating marine pollution (MEPC 54/WP.1, paragraphs 6.2 to 6.5).

7.20 The Committee noted the information provided in the presentation by IAEA on its work and approach to dealing with emergencies involving radiological and nuclear substances, including its responsibilities with respect to incidents occurring in ports and at sea, and the importance of the **Joint Radiation Plan of the International Organizations**, to which IMO would be contributing in 2006.

7.21 The Committee, having noted the ongoing co-operation of the IMO and IAEA Secretariats with respect to preparedness and response to nuclear and radiological incidents, also recognized that the topic was complex and generally outside the remit and expertise of the Technical Group, in particular, given that public vessels with nuclear-propulsion were not covered by any of the IMO instruments (MEPC 54/WP.1, paragraphs 6.6 to 6.9).

7.22 Having recognized that no new information was available on the **implementation of recommendations from the Third R&D Forum** and further noting the amount of time that has

passed since the last Forum in 2002, the Committee agreed to delete the item from the work programme of the OPRC-HNS Technical Group (MEPC 54/WP.1, paragraphs 6.10 and 6.11).

### **Technical co-operation implementation on OPRC and HNS**

7.23 The Committee, in noting the information on the technical co-operation activities undertaken in connection with OPRC and HNS during the period from January 2004 to December 2005, observed the important role played by workshops and training courses in catalysing and strengthening the co-operation between national authorities of any given region and between Governments and industry in the field of preparedness and response. The importance of such co-operation in ensuring viable response systems was also emphasized (MEPC 54/WP.1, paragraphs 7.1 to 7.9).

### **Work programme and provisional agenda for TG 5**

7.24 The Committee approved the work programme and provisional agenda for the fifth meeting of the OPRC-HNS Technical Group (MEPC 54/WP.1, paragraphs 8.1 and 8.2 and annex 2).

### **Any other business**

7.25 The Committee considered the proposal for the review and update of the **Manual on oil pollution, Section I – Prevention**, which is currently out of print. The delegation of Australia, supported by the delegations of New Zealand and Canada, highlighted that this manual is now redundant taking into account other more recent publications that address the topic of prevention, such as:

- MARPOL – How to do it (IMO), 2002;
- Safety Guide for Oil Tankers and Terminals (ISGOTT), 5<sup>th</sup> edition due in 2006;
- Prevention of Oil Spillage through Pump Room Sea Valves (ICS/OCIMF), 1991;
- Clean Seas Guide for Oil Tankers, 1993;
- Ship-to-Ship Transfer Guide; and
- Tanker Management and Self-Assessment – A Best Practice Guide for Ship Operators (OCIMF), 2005,

and therefore considered that an update was not necessary, as it would provide little added-value and would duplicate other manuals that are already in circulation and widely used. Other delegations, including the delegations of Panama, the United Kingdom and Venezuela, reminded the Committee that such publications were particularly important for developing countries and, given the importance of the topic, were of the view that a revision of the current manual was needed (MEPC 54/WP.1, paragraphs 9.2 to 9.5).

7.26 In attempting to reconcile the diverging views on the matter, the Committee concluded that rather than updating the Manual on oil pollution, Section I – Prevention, which is considerably out of date and out of print, and in an effort to avoid duplication, agreed that the “MARPOL – How to do it” manual should be reviewed and updated to include any relevant information from the Manual on oil pollution, Section I – Prevention not covered in the current edition of “MARPOL – How to do it” and instructed the Technical Group to initiate this review at its next meeting.

7.27 Further to its previous comment on the topic, the delegation of Venezuela informed the Committee of its intention to submit a proposal to the next session of MEPC that would consolidate the information on prevention found in the various IMO instruments and guidance manuals, as well as in the relevant publications of other organizations, with a view to updating the Manual on Oil Pollution, Section I – Prevention to serve as a systematic reference guide and to complete the five-part Manual on Oil Pollution series, which is currently missing Section I.

7.28 The Committee noted the comments of the Technical Group, which stressed that a meeting in October 2006 would be crucial to expedite the development and finalization of a number of important products the Group had on its work programme and that the present momentum should not be lost. The Committee approved, in principle, the scheduling of the fifth session of the OPRC-HNS Technical Group meeting the week prior to MEPC 55 and referred the matter to Council for decision, taking into account the financial implications involved and any potential offers of assistance received from Members and International Organizations (MEPC 54/WP.1, paragraphs 9.6 to 9.8).

7.29 The Committee noted the information provided by the delegation of Poland on the upcoming Balex Delta Exercise 2006 it will host in Gdynia from 5 to 7 September 2006 in (MEPC 54/WP.1, paragraph 9.10).

7.30 The Committee approved the report in general.

## **8 IDENTIFICATION AND PROTECTION OF SPECIAL AREAS AND PARTICULARLY SENSITIVE SEA AREAS**

### **Outstanding PSSA issues**

8.1 The Committee recalled that MEPC 53 decided that the Technical Group on PSSAs would need to be re-established at MEPC 54 to: review the Guidance Document for Submission of PSSA Proposals to IMO (MEPC/Circ.398); develop a uniform format of the MEPC resolutions to designate PSSAs; and review the PSSA Proposal Review Form.

8.2 With regard to the Review Form the Committee recalled that the United States, in its submission to MEPC 52 (MEPC 52/8), suggested that this form be eliminated because it tended to promote a “yes” or “no” inquiry rather than a thoughtful discussion of the proposed area in relation to the criteria. The Committee also recalled that ICS and INTERTANKO proposed a new review form, as shown in the annex to their paper (MEPC 52/8/3), the main aim being to ensure that sufficient information was provided in the application.

8.3 The Committee, having noted comments from the floor, agreed that the PSSA Proposal Review Form should be eliminated. However interested delegations could make submissions on this issue at future sessions. The Committee also agreed that the review of the Guidance Document for Submission of PSSA Proposals to IMO (MEPC/Circ.398); and the development of a uniform format of the MEPC resolutions to designate PSSAs be added to the Terms of Reference of the Technical Group on PSSAs.

### **Outcome of Assembly 24 in relation to PSSAs**

8.4 The Committee noted the Outcomes of A 24, as contained in document MEPC 54/11/1, paragraphs 9, 10 and 13 to 16, and in particular, that Assembly:

- .1 had adopted resolution A.982(24) on the revised PSSA Guidelines with the objective of clarifying and, where appropriate, strengthening the current PSSA Guidelines and had requested the Committee and the MSC to keep the Guidelines under review; and
- .2 had adopted two resolutions relating to Ships' Routeing Associated Protective Measures (APMs) for the Galapagos Archipelago PSSA and the Baltic Sea area PSSA, as resolution A.976(24) and A.977(24) respectively. The Committee also noted that the Ships' Routeing APMs for both PSSAs would be implemented at 0000 hours UTC on 1 July 2006.

8.5 In relation to the Galapagos Archipelago PSSA APM, the Committee noted that Assembly had requested the Committee to consider amending the geographical positions of the co-ordinates of the Area to be Avoided (as proposed by Ecuador in document A 24/9/4 in respect of the change in the specified chart datum) including the reference chart number, in annex 3 to resolution MEPC.135(53). Having noted that these modifications were of purely technical nature and did not affect the status of the already designated PSSA for the Galapagos Archipelago and the date of taking effect of the Area to be Avoided, the Committee instructed the Secretariat to issue a corrigendum to annex 23 of MEPC 53/24/Add.2, accordingly.

8.6 The delegation of Portugal, speaking on behalf of the six participant countries in the Western European PSSA (Belgium, France, Ireland, Portugal, Spain and the United Kingdom), informed the Committee on the progress and experiences gained in implementing the WETREP mandatory ship reporting system. The Committee noted that, since 1 July 2005, over two thousand reports had been received. While this was an encouraging start, some start-up problems had occurred with some reports containing incomplete data and other reports being sent by ships not required to do so. In an effort to correct this situation, a dialogue with industry was taking place. The Committee was reminded of resolution MSC.190(79) on the adoption of the mandatory ship reporting system in the Western European PSSA.

### **Proposal for the designation of South Africa's southern continental shelf waters as a Special Area under MARPOL Annex I**

8.7 The Committee noted the information provided by South Africa (MEPC 54/8 and MEPC 54/INF.2) on a proposal for the designation of South Africa's southern continental shelf waters as a Special Area under MARPOL Annex I. It also noted that the area in question was oceanographically unique and hosted a large number of endemic species, some of these and other species for which the proposed Special Area constituted an important habitat, were classified as threatened under the IUCN 'Red List' criteria. Significantly this included the African penguin, Cape gannet, and three cormorant species. The Committee further noted that operational oil discharges and spills from international and domestic shipping constituted risks to these species and the environment sustaining them.

8.8 The Committee, having heard the concerns expressed by India and others that the proposed area was not an enclosed or semi-enclosed sea and therefore may not satisfy the provisions of the Guidelines, noted that this was not a requirement (Guidelines paragraphs 2.1 and 2.2) and that other areas such as the Antarctica area and the North West European waters special areas were not enclosed or semi-enclosed sea areas. In response to requests regarding availability of port waste reception facilities in the proposed special area, the Committee noted that all major ports had adequate port reception facilities for the treatment of oil and oily wastes.



8.9 The Committee further noted that the majority of delegations that spoke supported South Africa's proposal subject to a complete and full analysis by the Technical Group on whether the information provided by South Africa addressed the provisions of the Guidelines for the Designation of Special Areas under MARPOL 73/78.

8.10 The Committee, in considering the comments made by the representative of UN-DOALOS regarding waters superjacent to a continental shelf, agreed that the words "Continental Shelf Waters" given by South Africa for the proposed special area did not reflect terminology used in UNCLOS and should be changed accordingly.

### **Instructions to the Technical Group**

8.11 Having considered all the relevant issues, including the proposal by South Africa, the Committee agreed that a Technical Group on Special Areas and Particularly Sensitive Sea Areas be established to:

- .1 review the proposal by South Africa for the designation of South Africa's southern continental shelf waters as a Special Area under MARPOL Annex I as contained in documents MEPC 54/8 and MEPC 54/INF.2 and determine whether it addresses the provisions of the Guidelines for the Designation of Special Areas under MARPOL 73/78 (Annex 1 of resolution A.927(22)); if so, prepare a draft amendment to relevant regulation of the revised MARPOL Annex I for consideration by the plenary;
- .2 develop a uniform format of the MEPC resolutions to designate PSSAs;
- .3 review and amend the Guidance Document for Submission of PSSA Proposals to IMO (document MEPC/Circ.398) to bring it into line with the revised PSSA Guidelines (annex to Assembly resolution A.982(24)); and
- .4 provide a written report to plenary on Thursday, 23 March 2006.

### **Report of the Technical Group**

8.12 In introducing the report of the Technical Group on Special Areas and Particularly Sensitive Sea Areas (MEPC 54/WP.9), the Chairperson, Ms. Lindy Johnson (United States), drew the attention of the Committee to the following:

- .1 the Technical Group had carried out a robust review of the South African proposal against the requirements of MARPOL Annex I relative to the designation of Special Area, including pertinent regulations of 1(11), 15, 34 and 38, and the Guidelines for the Designation of Special Areas under MARPOL, and agreed that the basic MARPOL requirements for areas outside Special Areas were unacceptable in light of the existing oceanographical and ecological conditions. Furthermore, having noted information provided by South Africa on port reception facilities, the Technical Group agreed that there were adequate reception facilities in the proposed Special Area; and
- .2 the Technical Group agreed that the proposal fully met the requirements to designate the area as a Special Area, and recommended that the Committee agree

to such designation and that this area be named the “Southern South African sea area”.

8.13 The Chairperson also stated that, in discussing the issue of illegal discharges within the area proposed for designation, the Technical Group noted that South Africa should explore mechanisms for enforcement in the area, especially in light of the theme for World Maritime Day. In this regard, it was suggested that perhaps this issue should be taken into account by the Committee when it discusses, at an appropriate time, the expansion of the Long-Range Identification and Tracking Systems on Ships to address environmental issues.

8.14 With regard to any future proposals for Special Areas, the Chairperson suggested that the Committee urge proposing States to bring a full scale nautical chart with the area marked on it. In addition it was noted that it may be helpful for such States to review the report of the assessment of the South African proposal so that they are familiar with the type of information necessary to satisfy the MARPOL requirements and the Guidelines for the Designation of Special Areas under MARPOL.

8.15 The Chairperson also stated that the Technical Group was able to develop a draft uniform resolution for the adoption of PSSA proposals and agree to revisions of the Guidance Document for Submissions of PSSA Proposals to IMO.

8.16 Having considered the report of the Technical Group (MEPC 54/WP.9), the Committee approved the report in general and in particular:

- .1 agreed to the designation of the southern South African sea area as a Special Area under MARPOL Annex I and approved the draft amendment in respect of the Special Area to regulation 1(11) of the revised MARPOL Annex I, as set out in annex 10 and invited the Secretary-General to circulate it in accordance with the MARPOL amendment procedures after MEPC 54 for consideration with a view to adoption at MEPC 55;
- .2 approved a uniform format of the MEPC resolution to designate PSSAs as set out in annex 11; and
- .3 approved the revised Guidance Document for Submission of PSSA Proposals to IMO, as set out in annex 12, and instructed the Secretariat to issue it as an MEPC circular (MEPC/Circ.510) as soon as possible.

8.17 The Committee expressed its appreciation to the members of the Technical Group for their hard work and, especially to Ms. Johnson for her untiring efforts in leading the Group to a successful conclusion of the work.

8.18 The delegation of South Africa thanked the Committee for the designation of the Special Area under MARPOL Annex I in the Southern South African sea area. It stressed that this would now increase the chance future generations have: to be able to appreciate the sights of the rich marine biodiversity in South Africa; enjoy the pristine southern coastal areas; and benefit from the rich food and economic marine resources still prevalent in the area.

8.19 South Africa, in noting the decision made by the Committee to agree to the designation of the southern South Africa sea area as a Special Area under MARPOL Annex I, and in confirming that there were adequate reception facilities in the area, and further noting that, given the

MARPOL amendment procedures, the Special Area status will not enter into force before 2008, requested the Committee to ask Member Governments and industry groups to urge oil tankers, on a voluntary basis, to refrain from washing their cargo tanks in the area, pending the entry into force. It further requested that this information be disseminated in the widest manner possible, which may include an MEPC Circular, Information papers to the Maritime Safety Committee, and to the Safety of Navigation Sub-Committee, as appropriate.

8.20 The Committee agreed to this request and instructed the Secretariat to develop a draft MEPC circular to facilitate the wide dissemination of this request in relation to oil tankers, for adoption at MEPC 55.

## **9 INADEQUACY OF RECEPTION FACILITIES**

9.1 In considering this standing item, the Committee emphasized the importance of adequate reception facilities in the chain of implementation of the MARPOL Convention. Therefore the Committee urged all Parties to the MARPOL Convention, particularly those Parties as port States, to fulfil their treaty obligations on providing reception facilities for wastes generated during the normal operation of ships.

9.2 The Committee recalled that MEPC 53, in considering the outcome of FSI 13 on the matter, approved MEPC/Circ.469 on “Revised consolidated format for reporting alleged inadequacy of port reception facilities”, superseding MEPC/Circ.349. The Committee encouraged all parties concerned to use this reporting format as a tool to promote the provision of reception facilities.

### **Port Reception Facility Database**

9.3 The Committee recalled also that MEPC 53 endorsed a recommendation of FSI 13 concerning development of the Port Reception Facility Database (PRFD) as a module of the IMO Global Integrated Shipping Information System (GISIS), and requested the Secretariat to develop such a database.

9.4 The Committee was pleased to note that the Secretariat had been able to finalize the Internet-based Port Reception Facility Database (PRFD). The Database was designed to allow Member States to update the Database via a log-in password, and to allow the public to access all the information in the Database on a view-only basis. The relevant information for the Database had been circulated by Circular letter No. 2683 in November 2005. The Database went live to the public on 1 March 2006, after a three-month trial period.

9.5 In this respect, the Committee endorsed the view of the FSI Sub-Committee (FSI 13/23, paragraph 19.20), that the hard-copy circulation of MEPC.3/Circular and MEPC.4/Circular on port reception facilities would be discontinued.

### **Draft Action Plan for Port Reception Facilities**

9.6 The Committee noted that, as requested by MEPC 53 in a renewed effort to tackle the inadequacy of port reception facilities, the Secretariat had prepared a draft Action Plan, which had been submitted to FSI 14 as document FSI 14/13 for consideration. The outcome of FSI 14 on the matter would be reported to the next session of the Committee (MEPC 55).

## 10 REPORTS OF SUB-COMMITTEES

### Outcome of DSC 10

10.1 The Committee noted that the Sub-Committee on Dangerous Goods, Solid Cargoes and Containers (DSC) held its tenth session from 26 to 30 September 2005 and its report was circulated under the symbol DSC 10/17.

10.2 The Committee took action on all matters referred to it by the Sub-Committee (MEPC 54/10) as indicated hereunder.

10.3 The Committee approved the text of the draft amendments to MARPOL Annex III, set out at annex 13, and requested that the text be circulated by the Secretary-General as soon as possible after this session for adoption by MEPC 55 (October 2006).

10.4 The Committee endorsed the timeframe, set out at annex 14, for the entry into force date of the amended MARPOL Annex III. This timeframe was developed and agreed by DSC 10 so that the new provisions for marine pollutants would be incorporated in Amendment 34-08 of the IMDG Code, thereby providing a reasonable transition as well as maintaining the recognized process and respecting the cycle of introducing amendments in the IMDG Code.

10.5 The Committee recalled that MEPC 51 had recognized that the application of the GHS criteria to the IMO definition of Marine Pollutants would result in there being no need to distinguish Severe Marine Pollutants from the general definition of Marine Pollutants. Furthermore, it agreed that the deletion of Severe Marine Pollutants would have an effect on the 1973 Intervention Protocol which, at that time, applied to Severe Marine Pollutants only but, in the future, would have to be amended to cover all Marine Pollutants.

10.6 The Committee considered the amendments to the List of Substances referred to in paragraph 2(a) of Article 1 of the Protocol relating to the Intervention on the High Seas in Cases of Pollution by Substances other than Oil, 1973.

10.7 The Committee noted that the List of Substances referred to in paragraph 2(a) of Article 1 of the Protocol relating to the Intervention on the High Seas in Cases of Pollution by Substances other than Oil, 1973 also referred to Noxious Liquid Substances as defined by MARPOL Annex II, and that this would be reviewed by BLG 10 in light of the revised MARPOL Annex II and the amended IBC Code.

10.8 In this context, the Committee requested the Secretariat to prepare a document, which should incorporate all the amendments to the List concerning harmful substances and noxious liquid substances, for approval at MEPC 55 and for subsequent adoption at MEPC 56.

10.9 The Committee approved the draft MSC/MEPC circular on disposal of fumigants as modified in the annex to MSC 81/12/1 and agreed to delete, from the draft circular, the reference to the 2000 edition of the supplement to the IMDG Code. It invited MSC to concur with the proposal and take other action as appropriate.

### **Urgent matters emanating from DE 49**

10.10 The Committee recalled that the Sub-Committee on Ship Design and Equipment held its forty-ninth session from 20 to 24 February 2006 and its report was issued under the symbol DE 49/20.

10.11 The Committee noted the urgent matters emanating from DE 49 and took action on those items referred to it by the Sub-Committee (MEPC 54/10/6).

10.12 The Committee considered the proposed amendments to the Condition Assessment Scheme (MEPC 54/10/6, annex 1). It agreed to replace the existing text of paragraph 13.8.2 with the following:

“there is a change in the recognized organization from the recognized organization that performed the CAS survey work and prepared the CAS final report, which was reviewed and accepted by the Administration for the issuance of the Statement of Compliance by the Administration, to a new recognized organization acceptable to the Administration, and that all information required to be submitted under the requirements of this resolution has been provided to the new recognized organization, or”,.

10.13 The Committee approved the proposed amendments to the Condition Assessment Scheme set out in annex 15 and requested that they be circulated by the Secretary-General as soon as possible after this session for adoption by MEPC 55.

10.14 The Committee adopted the Guidelines on the assessment of residual fillet weld between deck plating and longitudinals by MEPC resolution 147(54), which is set out at annex 16, and endorsed the view of the Sub-Committee that the thickness measurement of the residual fillet weld between deck plating and longitudinals during the course of a CAS survey could be used on an optional and voluntary basis by surveyors.

10.15 The Committee approved the Revised Guidelines for systems for handling oily wastes in machinery spaces of ships incorporating guidance notes for an integrated bilge water treatment system (IBTS), as set out in annex 17, and requested the Secretariat to issue it as an MEPC circular (MEPC/Circ.511) as soon as possible after adapting the cross-references in its text to the new numbering system in the revised MARPOL Annex I (see paragraph 14.5). In this regard, the Committee considered that the work was complete and agreed to delete the item from the Sub-Committee’s work programme.

10.16 The Committee noted the view of the Sub-Committee, that the regulation concerning the applicability of SOLAS regulation II-1/3-6 to single-hull tankers being converted to double-hull tankers, should not apply to such conversions or tankers converting to FPSOs/FSUs, however, if in the course of the conversion substantial new structures were added, these new structures should comply with the regulation.

### **Outcome of SLF 47 and SLF 48**

10.17 The Committee recalled that the Sub-Committee on Stability and Load Lines and on Fishing Vessels Safety (SLF) held its forty-seventh and its forty-eighth sessions from 13 to 17 September 2004 and from 12 to 16 September 2005 reports. The reports of these sessions were circulated under the symbols SLF 47/17 and SLF 48/21, respectively.

10.18 The Committee took action on the relevant matters referred to it by SLF 47 and SLF 48 (MEPC 54/10/3) as indicated hereunder.

10.19 With regard to SLF 47, the Committee approved the draft Unified Interpretation to regulation 25A of MARPOL Annex I, set out at annex 18, and agreed that the Unified Interpretation should also apply to regulation 27 of the revised MARPOL Annex I which was expected to enter into force on 1 January 2007.

10.20 With regard to SLF 48, the Committee noted the Sub-Committee's referral of the draft amendments to the LHNS Guidelines (Guidelines for the transport and handling of limited amounts of hazardous and noxious liquid substances in bulk on offshore support vessels – resolution A.673(16)) to the DSC Sub-Committee for finalization at DSC 11 for subsequent submission to the MSC and the MEPC, for adoption, as well as the Sub-Committee's referral of the model form of Certificate of Fitness contained in the draft amendments to the LHNS Guidelines to the BLG Sub-Committee (BLG 10) for comments.

10.21 The Committee considered the proposal by the United Kingdom that the list of products contained in Appendix 1 – Table of Permitted Cargoes in the LHNS Guidelines be updated to include all the products that could be carried offshore under these guidelines (MEPC 54/10/4).

10.22 Noting that the revised MARPOL Annex II and the amended IBC Code are expected to enter into force on 1 January 2007, the Committee instructed the BLG Sub-Committee (BLG 10) to consider the draft model form of Certificate of Fitness contained in the draft amendments to the LHNS Guidelines as indicated by SLF 48 as well as the proposal by the United Kingdom to update and considerate the list of products contained in Appendix 1 - Table of Permitted Cargoes of the LHNS Guidelines with a view to approval at MEPC 55.

10.23 The Committee noted that the draft amendments to the LHNS Guidelines would be discussed by the DSC 11 in September 2006, and which would finalize a consolidated version of the draft LHNS amendments emanating from SLF 48 (September 2005), BLG 10 (April 2006) and DSC 11 (September 2006) for adoption by MEPC 55 and subsequently by MSC 82.

10.24 The Committee noted and agreed to SLF 48's recommendation that no transitory deviation from safety standards (i.e. intact and damage stability and load line standards), should be permitted during ballast water exchange.

#### **Amendments to the Guidelines for the provisional assessment of liquids transported in bulk (MEPC/Circ.265)**

10.25 The Committee recalled that among the outstanding guidelines from BLG 9, referenced in the 2002 consolidated edition of MARPOL 73/78, which still required consideration, were the Guidelines for the Provisional assessment of liquids transported in bulk (MEPC/Circ.265).

10.26 The Committee further recalled that at BLG 9, due to time constraints, the work on the revision of these Guidelines could not be completed and the Sub-Committee had therefore instructed the Working Group on the Evaluation of Safety and Pollution Hazards of Chemicals (ESPH) to finalize this work during its next intersessional meeting (ESPH 11, 24 to 28 October 2005). MEPC 53 had authorized ESPH 11 to submit the draft revised Guidelines directly to MEPC 54 for approval and to be circulated at the earliest opportunity.

10.27 The Committee approved the revised Guidelines for the Provisional assessment of liquids transported in bulk which would supersede those in MEPC/Circ.265, as set out at annex 19, to be issued under a new circular number (MEPC/Circ.512). In this context, the Committee, following an intervention by a delegation, urged the industry, in particular the chemical industry, to provide information on the revision of List 2 of the MEPC.2/Circular, which contained pollutant only mixtures based on section 5 of the revised Guidelines.

10.28 The Committee thanked the delegation of the Netherlands for its offer to the IMO of the computer programme it developed which would be put on the IMO's public domain website to facilitate the mixture calculation under the revised Guidelines by interested stakeholders.

10.29 The Committee noted an intersessional meeting of the ESPH Working Group (ESPH 12) was scheduled for September 2006. The Committee, taking into account the meeting schedule (BLG 10, 3 to 7 April 2006; GESAMP/EHS, tentatively set for June 2006; ESPH 12, September 2006; MEPC 55, 9 to 13 October 2006 and MSC 82, 4 to 8 November 2006) and the important decisions that needed to be taken by MEPC on certain items to be considered by ESPH 12 before the entry into force date of 1 January 2007 for the amended MARPOL Annex II and the revised IBC Code, allowed BLG 10 to identify those items from ESPH 12 to be reported directly to MEPC 55.

10.30 The Committee noted the information in MEPC 54/INF.7 on the GESAMP/EHS Composite List of Hazard Profiles.

10.31 The Committee was also informed that, following the forty-second session of the GESAMP/EHS Working Group held from 20 to 24 February 2006, the Composite List of Hazard Profiles was substantially complete. The Composite List had been issued as an annex to the report of the forty-second session of the GESAMP Working Group under the symbol BLG/Circ.16 and was available on the IMO website and had been circulated to interested stakeholders.

10.32 The Committee further noted that under the revised Guidelines for the provisional assessment of liquids transported in bulk, the GESAMP/EHS Composite List of Hazard Profiles was utilized when carrying out a provisional assessment.

10.33 The Committee were also informed that, due to time constraints, further work was required by the GESAMP/EHS Working Group which had a bearing on the classification of products under the revised IBC Code, which is expected to enter into force on 1 January 2007. The Working Group felt it necessary to have another meeting tentatively scheduled in June 2006.

10.34 The Secretariat informed the Committee that IMO had funded the regular annual meeting of the GESAMP/EHS Working Group held in February 2006. However, as there was no budgetary allocation for another meeting this year, the support of interested parties attending MEPC to fund this extra meeting was being sought. The cost of such a meeting was estimated to be in the region of £35,000.

10.35 The Committee noted the information provided and thanked the GESAMP/EHS Working Group for its invaluable work. Regarding the funds for an additional meeting of the GESAMP/EHS Working Group, the Committee was informed by the delegation of the Netherlands that, even though the June meeting of the GESAMP/EHS Working Group was not planned for, it has found the funds for its representative to participate in this meeting under the usual conditions should the meeting take place. In this regard, it invited others, in particular the

industry, to carefully study their budgets in order that funding can be found to support such a meeting.

10.36 The delegations of Panama and Malta, supported by a number of delegations, expressed the view that those submitting their cargoes for evaluation should contribute to the funding of the GESAMP/EHS Working Group which is tasked under the global system to carry out these evaluations so that these entities will in turn have the benefit of ships regulated by this Organization to carry their cargoes. This in fact is in line with the way that the GESAMP Ballast Water Working Group is funded.

10.37 Following extensive deliberations to find a viable solution to funding the GESAMP/EHS meeting in June, the Committee suggested that in the absence of finding the funding from donors, and subject to adherence to the financial rules of the Organization, the meeting should be funded by the budgetary allocation for next year's GESAMP/EHS regular meeting and to inform the Council of the current difficulty in financing GESAMP/EHS meetings. The Committee also agreed that a long-term funding solution needs to be found which should involve those cargo interests, namely manufacturers of the products, which benefit directly from the work of the group.

10.38 In considering document MEPC 54/10/3 submitted by the United Kingdom, the Committee noted that, as a consequence of the work carried out by the forty-first session of the GESAMP/EHS and the eleventh session of the ESPH Working Group, some vegetable oils have been (re-)evaluated and consequentially identified as presenting both pollution and safety hazards.

10.39 The Committee also noted that the information on the (re-)evaluation was important as it indicated that some vegetable oils could present a safety risk from an operational point of view. However, it was also noted that the notation of the safety hazard ("s" in column *d* of chapter 17 of the amended IBC Code) did not impact on the carriage requirements when carrying these vegetable oils under the amended IBC Code.

10.40 The Committee further noted that under paragraph 1.1.2 of the Guidelines for the transport of vegetable oils in deep tanks or in independent tanks specifically designed for the carriage of such vegetable oils in general dry cargo ships (resolution MEPC.120(52)), only vegetable oils identified as a pollution hazard (P only) in column *d* of chapter 17 of the amended IBC Code were permitted to be carried.

10.41 The Committee therefore agreed to amend paragraph 1.1.2 of these Guidelines so that unmodified vegetable oils with an S/P notation in column *d* of chapter 17 of the amended IBC Code could be carried in deep tanks or in independent tanks specifically designed for the carriage of such vegetable oils in general dry cargo ships.

10.42 The Committee, recognizing that the revised Guidelines would take effect on 1 January 2007, agreed that, for ease of reference and use, a new MEPC resolution be prepared that would supersede the existing resolution MEPC.120(52). In view of the need by industry to be aware of these changes as soon as possible, the Committee tasked the Secretariat to prepare the draft text of the resolution for adoption at this session. Having considered document MEPC 54/WP.11, the Committee adopted, by resolution MEPC.148(54), the revised guidelines, which is set out at annex 20.



## **Recommendations on the safe transport of dangerous cargoes and related activities in port areas**

10.43 The Committee recalled that, in light of the DSC Sub-Committee's decision to extend the target completion date of this work programme to 2006, MEPC 53 agreed to consider the matter at this session (MEPC 54).

10.44 The Committee also recalled that DSC 9, as the co-ordinating Sub-Committee for this work, had noted that some aspects of the Recommendations addressed marine pollutants, environmental issues and other matters which fell under the scope of MARPOL 73/78. As these fell under the purview of the MEPC, the Sub-Committee did not examine either the marine pollution aspects of the Recommendations or annex 5 of the Recommendations on Bunkering Precautions, including the Bunkering checklist.

10.45 The Chairman of the DSC Committee informed the meeting that DSC had raised some issues on annex 5 of Recommendations on Bunkering Precautions and suggested to the Committee that these be addressed by the BLG Sub-Committee. The Committee concurred with this suggestion and instructed BLG 10 to review these issues and report back to DSC 11 for final approval of the Recommendations by MEPC 55 and MSC 82. The Committee also agreed that as part of the work to be carried out by BLG 10, consideration would be given to referencing the appropriate provisions of the OPRC/HNS Protocol to bring these to the attention of port authorities.

## **11 WORK OF OTHER BODIES**

### **Outcomes of A 24 and C/ES.23**

11.1 The Committee noted that the Assembly, at its twenty-fourth session, had noted those issues arising from the fiftieth to the fifty-third sessions of the Committee, which were brought to its attention (A 24/5(b)/2; MEPC 54/11/1 and Addendum 1). The Assembly had, in particular:

- .1 noted that, in connection with the revised MARPOL Annex II, regulation 4.1.3 of that Annex was the regulation to be used for an exemption for the carriage of vegetable oils, encouraging Administrations to grant such an exemption. In connection with the revised IBC Code, a number of additional hazard profiles of products taken from a previously updated list were completed in November 2005, following the receipt of additional data from industry. In response to a request of Committee 2 of the Assembly, the Secretariat had produced a further updated list of products including the status of their associated hazard profiles for information purposes, as shown in annex 2 to document A 24/5(b)/2.

It should be recalled that, with regard to the revised MARPOL Annex II, which was expected to enter into force on 1 January 2007, regulation 4.1.3 was developed, allowing unmodified oils and fats, displaying footnote (k) in column e in Chapter 17 of the amended IBC Code, to be carried on ship type 3 chemical tankers, under the condition that these chemical tankers shall meet **all** requirements for ship type 3 and are provided with double bottom and double sides meeting the specifications laid out within regulation 4.1.3. The Certificate of Fitness of any such vessel shall indicate that the vessel is entitled to operate under the provisions of this regulation. The Committee noted that the Secretariat would issue a circular letter to summarise the principal points of the revision

process of MARPOL Annex II and the IBC Code to ensure that all stakeholders would be aware of their obligations as from 1 January 2007;

- .2 adopted resolution A.981(24) on the development, as a high priority, of a new legally-binding instrument on ship recycling and requested the Committee to work towards completion of such an instrument in time for consideration and adoption in the biennium 2008-2009. The Assembly had also adopted, by resolution A.980(24), amendments to the IMO Guidelines on Ship Recycling, and urged Governments and all stakeholders to apply these Guidelines without delay;
- .3 noted the Committee's plan to undertake a general review of MARPOL Annex VI and the NO<sub>x</sub> Technical Code with a view to revising the regulations to take account of current technology and the need to further reduce air pollution from ships with a target completion date of 2007;
- .4 adopted resolution A.982(24) on the revised PSSA Guidelines with the objective of clarifying and, where appropriate, strengthening the current PSSA Guidelines and requested the Committee and the MSC to keep the Guidelines under review;
- .5 adopted resolution A.983(24) on the Guidelines for the facilitation of response to a pollution incident; and
- .6 noted the Committee's decision to include a high priority item on "Amendments to MARPOL Annex I for the prevention of marine pollution during oil transfer operation between ships at sea" in the work programme of the BLG Sub-Committee, with a target completion date of 2007.

11.2 The Committee noted that the Associated Protective Measures for the Baltic Sea Area PSSA and the Galapagos Archipelago PSSA, adopted at the Assembly, by resolution A.976(24) and A.977(24) respectively, had already been considered under item 8 on PSSAs.

11.3 With regard to the reference in document MEPC 54/11/1, paragraph 4, concerning the entry into force of the revised MARPOL Annex II on 1 January 2007, the Committee confirmed that:

- .1 regulation 4.1.3 was the only regulation for existing and new ships to be used for vegetable oils identified by footnote (k) in column e in Chapter 17 of the amended IBC Code; and
- .2 regulations 4.1.1 and 4.1.2 were only developed to allow Administrations to submit to the Organization a relaxation of certain provisions of an amendment under restricted conditions, for a specified period and for existing ships only, and these regulations were not to be allowed to be used for the vegetable oils under footnote (k).

11.4 The delegation of Panama announced that the Panamanian Administration would grant exemption for the carriage of vegetable oils under regulation 4.1.3 of the new MARPOL Annex II.

### **Strategic Plan, High-level Action Plan and priorities**

11.5 The Committee noted that the Assembly had adopted resolution A.970(24) which sets out a mission statement of the Organization, trends, developments and challenges, strategic directions and related performance indicators. It also adopted resolution A.971(24) replacing the Long-term work plan of the Organization with the high-level actions related to the directions of the Strategic Plan for the Organization and on the consequent planned output of the Committees during the current biennium. The Committee noted, in particular, the request of the Assembly in resolution A.971(24) to all Committees:

- .1 that they, when reporting on their work to the twenty-fifth session of the Assembly in 2007, should report progress toward fulfilling the Organization's aims and objectives using the framework of the high-level actions and planned biennial outcomes;
- .2 that they, when considering proposals for new work programme items, should ensure that the issues to be addressed are those which fall within the scope of the Strategic Plan;
- .3 that they should review their Guidelines on the organization and method of their work and, as appropriate, that of their subsidiary bodies (MEPC/Circ.405), in order to require that submissions for new work programme items include an indication of how they relate to the scope of the Strategic Plan; and finally,
- .4 that they, when making recommendations for their work programmes during the Strategic Plan period, should bear in mind the desirability of scheduling no more than one diplomatic conference in each year, save in exceptional circumstances.

11.6 The twenty-third extraordinary session of the Council had identified a number of issues in this regard (C/ES.23/D; MEPC 54/11/3, paragraph 14, and annexes 1, 2, and 3) and had invited the Committee to:

- .1 take into account the advice of the *Ad Hoc* Council Working Group in the context of prioritization of its work during the 2006-2007 biennium;
- .2 set aside sufficient time at this and future sessions for considering the high-level actions and their associated priorities for the 2006-2007 biennium, in order to ensure that they both accurately and concisely describe their planned activities; and
- .3 note the revised reporting cycle for the 2006-2007 biennium.

11.7 The Committee noted the outcomes of the Assembly and the Council on these issues, and agreed to act in accordance with the requests of the Assembly and the Council listed in paragraphs 11.5 and 11.6 above.

### **Outcome of FAL 32**

11.8 The Committee was informed of the outcome of the thirty-second session of the FAL Committee held in July 2005 and as reported in FAL 32/22. Document MEPC 54/11/2 summarized FAL's support to the proposal by ICS concerning on-line access to certificates and

documents required to be carried on board ships (FAL 32/15) and invited the Committee to consider whether access by port State control officers to the information on certificates of ships engaged in international voyages would be facilitated and simplified through the use of modern technology. The FAL Committee agreed that:

- .1 before it could start to study the information technology requirements for such an on-line system, feedback on the acceptability, feasibility and practicability of the system would be required from MEPC and MSC; and
- .2 it would need advice from the Committees on the issue of which certificates might be made accessible by electronic systems.

11.9 The observer from INTERTANKO, in introducing document MEPC 54/11/4, informed the Committee of the on-line access to ships' certificates and documents which was currently operational through the Q88.com system and the experience of INTERTANKO members with this system. INTERTANKO believed the Q88.com system could be used as an example of how on-line access to vessel certificate data by port State authorities prior to the vessels arrival could fulfil the advantages identified by FAL (MEPC 54/11/2, paragraph 3).

11.10 During the discussion about on-line access to ships' certificates and documents, the following concerns were expressed:

- .1 many practical problems had yet to be resolved with regard to the structure, content, and security aspects of on-line data, as well as the robustness of the information technology systems to be applied;
- .2 several delegations objected to using a commercial database for communication on statutory documents between ship-owners and port State control. Some delegations suggested that this would be a task for IMO and that the experience of other intergovernmental bodies in this regard would be a useful reference;
- .3 should online access to ships' certificates and documents complement or substitute paper documents on board vessels? Liability issues might arise, if in case of substitution the data provided appeared to be out of date. Substitution might even require amendments to Article 5 of the MARPOL Convention concerning the availability of certificates on board vessels for inspection purposes; and
- .4 creating and relying on on-line access to ships' certificates and documents would have implications for crews, flag State and port State Administrations, which would have to be addressed.

11.11 The Director of the Maritime Safety Division informed the Committee that the focus of the discussions in FAL was on the facilitation of easy access to certificates for inspection purposes under various IMO Conventions, which would not necessarily mean substitution of paper documents kept on board.

11.12 A number of delegations supported the proposal for online access to certificates and expressed the view that the FAL Committee should explore the matter further, including reliability and security of such databases.

11.13 The Chairman stated that, whilst many delegations supported the idea of online access to ships' certificates and documents in principle, there were only a few comments on the acceptability, feasibility and practicability of online access systems (MEPC 54/11/2, paragraph 6) as requested by the FAL Committee. The concept of port State control was based on inspection of ships after their arrival in port. The issue of giving port States access to information on ships' certificates and documents on a pre-arrival basis changed this concept. However, in view of the potential advantages, the FAL Committee might examine the matter further.

11.14 The Committee felt that it was not ready to advise the FAL Committee on the acceptability, feasibility and practicability of online access of certificates for inspection purposes.

11.15 Some delegations expressed concerns regarding commercially operated and controlled systems, the access to which was restricted on the basis of subscription.

11.16 The Committee took note of the information on the Q88.com system provided by INTERTANKO. However, the Committee could not endorse the system.

### **Outcome of the 27th Consultative Meeting of Contracting Parties to the London Convention**

11.17 The Committee was informed of the outcome of the 27th Consultative Meeting of Contracting Parties to the London Convention (October 2005), as reported in LC 27/16. In particular, the Committee was informed of the Consultative Meeting's acceptance of the establishment of the Joint London Convention/MEPC Correspondence Group and its terms of reference as agreed at MEPC 53, aimed at clarifying two boundary issues between MARPOL 73/78 and the London Convention and Protocol. With the entry into force on Friday, 24 March 2006, of the 1996 Protocol to the London Convention, this collaboration between the Committee and the Consultative Meeting gained in importance by enabling the new Protocol to make a good start. The report of the Joint Correspondence Group would be presented to MEPC 55.

11.18 The Committee noted the Consultative Meeting's acceptance of these arrangements and invited Member States to contribute to the work of the Joint Correspondence Group.

### **Outcome of the 60<sup>th</sup> session of the General Assembly of the United Nations**

11.19 The Committee was informed of the outcome of the 60<sup>th</sup> session of the UN General Assembly and, in particular, the adoption, on 29 November 2005, of resolutions A/RES/60/30 on Oceans and the law of the sea and A/RES/60/31 on Oceans and the law of the sea: sustainable fisheries, both of which contained elements that were of relevance to the work of the Committee (MEPC 54/11/5).

### **Marine debris and inadequacy of port waste reception facilities**

11.20 Resolution A/RES/60/30 of the UN General Assembly invited IMO to review MARPOL Annex V, in consultation with relevant organizations and bodies, and to assess its effectiveness in addressing sea-based sources of marine debris. The General Assembly welcomed the continued work of IMO relating to port waste reception facilities and noted the work done to identify problem areas and develop an Action Plan addressing the inadequacy of such facilities. In this context, the Committee was informed that, building on the formation of the shipping and port industry Reception Facilities Forum and its initiatives for enhancing the provision and use of port

reception facilities, a draft Action Plan had been developed, for consideration at FSI 14 in June 2006 (FSI 14/13).

11.21 The Committee reminded Member Governments, the shipping and port industries, and other interested organizations that further input to the continued development of the Action Plan to be discussed at FSI 14 was required.

11.22 The delegation of Australia indicated that tackling marine debris was a policy priority in Australia and referred to its document MEPC 54/INF.4 and Corr.1, outlining a number of marine debris reviews and studies conducted (see also chapter 20 of this report). The delegation welcomed the invitation of the UN General Assembly to review MARPOL Annex V.

11.23 The delegation of the Netherlands suggested that a review of MARPOL Annex V should also build on the future recommendations of the Joint London Convention/MEPC Correspondence Group when clarifying the two boundary issues between MARPOL 73/78 and the London Convention and Protocol, as this particularly addressed the discharge of garbage under MARPOL Annex V.

### **Discarded fishing gear and related marine debris**

11.24 Resolution A/RES/60/31 of the UN General Assembly, *inter alia*, called upon States, FAO, IMO, UNEP and all relevant regional organizations and stakeholders to take action to address the issue of lost or abandoned fishing gear and related marine debris, including through the collection of data on gear loss, economic costs to fisheries and other sectors, and the impact on marine ecosystems. It also encouraged close co-operation and co-ordination between all stakeholders through initiatives such as the analysis of the implementation and effectiveness of the existing measures relevant to the control and management of derelict fishing gear and related marine debris, the development and implementation of targeted studies to determine the socio-economic, technical and other factors that influence the accidental loss and deliberate disposal of fishing gear at sea, the assessment and implementation of preventive measures, incentives and/or disincentives relating to the loss and disposal of fishing gear at sea, and the development of best management practices.

11.25 The Secretary informed the Committee that IMO was co-operating with FAO and UNEP, under a GEF project dealing with marine debris. Regarding the co-operation with the FAO concerning discarded fishing gear, he proposed to add this item to the agenda of the Joint IMO/FAO Working Group on Illegal Unregulated and Unreported Fishing (IUU). The next meeting of the joint group was planned to take place in 2007 and IMO and FAO Secretariats were currently preparing the agenda for this meeting. IMO and FAO each designated seven experts as members to this group. The arrangement for the future meeting would be reported to MEPC 55 for action, as appropriate.

### **Regular process for global reporting and assessment of the state of the marine environment**

11.26 The Committee was informed that in resolution A/RES/60/30 the UN General Assembly had endorsed the conclusions of the second International Workshop, convened in June 2005, on the “regular process for global reporting and assessment of the state of the marine environment, including socio-economic aspects”, in short “the regular process” and had decided to launch the start-up phase, the “assessment of assessments”, in preparation for the “regular process” itself. In so doing, the UN General Assembly also agreed on the organizational arrangements and IMO

was explicitly mentioned as a member in the *Ad Hoc* Steering Group to oversee the execution of the “assessment of assessments”.

11.27 In conclusion, the Committee:

- .1 noted the invitation of the UN General Assembly and agreed to initiate the review of MARPOL Annex V, and to assess its effectiveness in addressing sea-based sources of marine debris;
- .2 invited delegations to submit proposals under the Committee’s relevant agenda items to review MARPOL Annex V for this purpose;
- .3 noted that the Secretariat was co-operating with FAO, UNEP and the GPA, regarding marine debris and, as requested in resolution A/RES/60/31, agreed to co-operate with FAO on discarded fishing gear – in particular through the Joint IMO/FAO Working Group on IUU Fishing; and
- .4 noted the establishment of and arrangements for launching the “assessment of assessments”, as a start-up phase for the “regular process”.

## 12 STATUS OF CONVENTIONS

12.1 The Committee noted the information on the status of IMO conventions and other instruments relating to marine environment protection (MEPC 54/12) as follows:

- .1 Annex 1 shows the status, as at 12 December 2005, of the IMO conventions and other instruments relating to marine environment protection;
- .2 Annex 2 shows the status, as at 12 December 2005, of MARPOL;
- .3 Annex 3 shows the status, as at 12 December 2005, of the amendments to MARPOL;
- .4 Annex 4 shows the status, as at 12 December 2005, of 1990 OPRC Convention;
- .5 Annex 5 shows the status, as at 12 December 2005, of 2000 OPRC-HNS Protocol;
- .6 Annex 6 shows the status, as at 12 December 2005, of 2001 AFS Convention; and
- .7 Annex 7 shows the status, as at 12 December 2005, of 2004 BWM Convention.

12.2 The Committee also noted the following information provided by the Secretariat since MEPC 54/12 was issued on 12 December 2005:

- .1 With regard to annex 2 of document MEPC 54/12 on the status of MARPOL:
  - .1 Belgium deposited its instrument of accession for Annex VI on 27 February 2006;
  - .2 Syrian Arab Republic deposited its instrument of accession for Annexes III, IV and V on 8 March 2006; and

- .3 Qatar deposited its instrument of accession for MARPOL Annexes I, II, III, IV and V on 8 March 2006.
  - .2 With regard to annex 4 of document MEPC 54/12 on the status of 1990 OPRC Convention:
    - .1 Portugal deposited its instrument of accession on 27 February 2006.
  - .3 With regard to annex 6 of the document MEPC 54/12 on the status of 2001 AFS Convention:
    - .1 Greece deposited its instrument of ratification on 22 December 2005; and
    - .2 Cyprus deposited its instrument of ratification on 23 December 2005.
- 12.3 The Committee further noted the following information from delegations:
- .1 the delegation of Japan stated that their Government would deposit their instrument of ratification for the 2000 OPRC-HNS Protocol in the near future;
  - .2 the delegation of China stated that their Government would deposit their instrument of ratification for MARPOL Annex VI soon and is in the ratification process for MARPOL Annex IV;
  - .3 the delegation of Italy stated that their Government would deposit their instruments of ratification for MARPOL Annex VI and the 1996 Protocol to the London Convention in the near future; and
  - .4 the delegation of Cyprus stated that their Government would deposit their instrument of accession to MARPOL Annex IV soon.

## **13 HARMFUL ANTI-FOULING SYSTEMS FOR SHIPS**

### **Practical guidance on article 5 of the AFS Convention**

13.1 The Committee recalled that, at its last session, in an effort to provide countries with practical guidance on article 5 of the AFS Convention, it invited Members to provide the Committee with examples of their Codes of Practice, Guidance Documents or other relevant documentation that could serve as a basis for the preparation of a concise guide on the environmentally sound management of wastes from the application or removal of an anti-fouling system controlled under the provisions of Annex 1 to the AFS Convention.

13.2 The Committee reiterated its invitation to Members to submit relevant information, if available, to MEPC 55 for consideration.

### **Update on the Anti-fouling Systems Convention**

13.3 The Committee noted that the entry into force of the AFS Convention was a step closer following recent ratifications, bringing the total number of Parties to the Convention to 16 States, representing about 17.3% of the world's merchant shipping. The Committee highlighted the



importance of bringing the AFS Convention into force as soon as possible, bearing in mind the 2008 deadline for a total prohibition of tin-based anti-fouling systems on ships.

#### **14 PROMOTION OF IMPLEMENTATION AND ENFORCEMENT OF MARPOL 73/78 AND RELATED INSTRUMENTS**

14.1 The Committee had before it the following documents: MEPC 54/14 (India) providing views on the need to address operational problems affecting waste oil management in machinery spaces of ships; MEPC 54/WP.3 (Secretariat) proposing the development of an internet-based Pollution Prevention Equipment database within the IMO GISIS system; and MEPC 54/WP.4 (Secretariat) with information on discrepancies encountered between the IMO CAS database and other databases concerning oil tanker CAS-related data.

##### **Operational problems affecting waste oil management in machinery spaces of ships**

14.2 In introducing its document MEPC 54/14, India drew the attention of the Committee to the serious operational problems most vessels were facing because, although being fitted with bilge oily water separators for machinery spaces complying with resolution MEPC.107(49), they had inadequate waste handling systems for machinery spaces, insufficient sludge/waste oil holding tanks and lesser incinerator capacity. In the view of India, recent reported incidents of MARPOL violations had demonstrated the inadequacy of guidelines for pollution prevention equipment provided on board ships for waste oil management for machinery spaces.

14.3 India focused its concern on the following matters for consideration:

- .1 the design and testing of bilge oily water separators should take into account on-board conditions and their capacity should be specified in relation to installed power plants and other factors;
- .2 incinerator capacity for waste oil and sludge should also be specified by regulations;
- .3 quality standards of fuel oil bunkers should be improved; and
- .4 positive steps, such as adequate reception facilities, should be offered to ships at a reasonable cost rather than initiating criminal proceedings against crews.

14.4 In the ensuing discussion the Committee recalled that, at the current session, it had taken measures which addressed some of the concerns expressed above. Firstly, under agenda item 6 it considered a proposal by Germany on the Harmonized Implementation of the Revised Guidelines and Specifications for Pollution Prevention Equipment for machinery space bilges of ships adopted by resolution MEPC.107(49). The proposal was intended to provide guidance concerning specifically the type-approval process with the aim of ensuring that realistic on-board operating conditions were taken into account during the tests. The Committee agreed to refer the proposal to the DE Sub-Committee for further consideration (see paragraph 6.23).

14.5 Secondly, under agenda item 10, the Committee had adopted the Revised Guidelines for systems for handling oily wastes in machinery spaces of ships incorporating Guidance notes for an Integrated Bilge Water Treatment System (IBTS) (see paragraph 10.15). The IBTS, in particular, was intended as a response to problems currently found on board ships as regards handling of oily wastes.

14.6 The delegations who spoke showed overwhelming support for the concerns of India, however, some delegations could not agree to the imposition of mandatory minimum capacity requirements for oily bilge water separators and incinerators, having instead a preference for an approach based on individual ships and their trading patterns, taking into account access to port reception facilities at likely ports of call.

14.7 In the course of the discussion, the Committee noted the information provided by INTERTANKO on its current work, relating to the issues raised by India, in connection with the launch of a project on best practices on engine room waste treatment and that it would submit the project, if completed in time, to MEPC 55. The Committee also noted that ICS, on its part, had produced a leaflet providing guidance on MARPOL compliance in respect of oily water separators and their use and maintenance and that the leaflet was available for delegations at the documents counter.

14.8 In concluding the debate, the Committee:

- .1 endorsed the views of India that inadequacy of oil pollution prevention equipment, in particular oily bilge separators, is a serious problem;
- .2 agreed to invite Member Governments and industry to provide concrete proposals, including draft MEPC circulars or proposed amendments to existing instruments, to a future session of the Committee in order to address this important matter; and
- .3 urged all Parties to the MARPOL Convention, especially port States, to fulfil their obligations under MARPOL by providing adequate reception facilities.

### **Electronic database for Pollution Prevention Equipment (PPE)**

14.9 The Secretariat, in document MEPC 54/WP.3, provided information on the current status of the annual MEPC.5/Circular series which disseminated information on Government type-approved PPE. It had been noticed that, over the years, some of the information on type-approved PPE currently stored in the latest issue (MEPC.5/Circ.9) was old and might be outdated.

14.10 The Committee noted that the number and extent of reports on PPE from Member Governments received by the Secretariat was currently quite low, as only three Member Governments had informed the Organization of any newly approved PPE in the previous year and that the possibility existed that there might be PPE in use of whose type approval IMO had not been notified. As a consequence, it might be argued that the object and purpose of issuing the MEPC.5/Circular series were not being fulfilled.

14.11 The Committee further noted the proposal by the Secretariat that, in order to address this issue and with the aim of facilitating global access to information on PPE worldwide whilst promoting the exchange and accuracy of PPE data, an electronic database be set up as a module within IMO's Global Integrated Shipping Information System (GISIS). The objectives of the database would be:

- .1 the dissemination of up-to-date information on approved PPE to the maritime community worldwide over the internet;
- .2 the regular updating of the information by Member Governments; and

- .3 the facilitation of user-friendly searches.

14.12 The Committee endorsed the above proposal and, in particular:

- .1 agreed to develop a PPE database as a module in GISIS;
- .2 agreed to discontinue issuing the annual MEPC.5/Circular series in hard copy; and
- .3 instructed the Secretariat to populate the database, once it has been created, with PPE information currently stored in the MEPC.5/Circular and, once this task has been completed, to issue a circular letter inviting Member Governments to review, amend and update relevant PPE data previously supplied by them prior to the database going public after a trial period of three months.

### **Issues relating to the Condition Assessment Scheme (CAS) database**

14.13 The Committee noted the information provided by the Secretariat in document MEPC 54/WP.4. The Committee, in particular, noted that the IMO CAS database, accessible only to MARPOL Parties as a module in GISIS, currently stores information on Statements of Compliance (SOC) issued by Governments to 76 CAS-compliant oil tankers whereas there are significant discrepancies as regards CAS-compliance data for those same tankers in the EQUASIS database.

14.14 The Committee recalled its previous decision at MEPC 48 whereby it had agreed that CAS information with regard to particulars of issued CAS Statements of Compliance (SOC) could be made available to EQUASIS, and that this decision had been endorsed at MEPC 49 (MEPC 49/22, paragraph 13.6).

14.15 The Committee further recalled that, at MEPC 53, it had approved MEPC/Circ.479 on Guidelines for port State control (PSC) officers whilst checking compliance with CAS, whereby it recommended that PSC officers should make use of the IMO CAS database for checking an oil tanker's CAS compliance (MEPC 53/24, paragraph 10.29).

14.16 The Committee held a debate focusing on the possible reasons why EQUASIS was not showing information supplied by the IMO Secretariat and the possible implications for the maritime community as regards the supply of reliable information on CAS compliance for oil tankers.

14.17 The Committee concluded that the IMO CAS database, as part of the IMO GISIS application, was the appropriate source for CAS-related information and that it would be desirable that information on valid Statements of Compliance be made available to the general public through GISIS, without prejudice to continue making them available to EQUASIS, as agreed at MEPC 48, after having solved any technical problems that might currently exist in relation to the method of supplying those data.

14.18 In concluding, the Committee:

- .1 instructed the Secretariat to take necessary steps so that the information on valid Statements of Compliance stored in the IMO CAS database be made freely available to the public through the IMO GISIS system;

- .2 urged MARPOL Parties to fulfil their obligation under section 14 of CAS to provide information to IMO for dissemination through the IMO CAS database; and
- .3 instructed the Secretariat to contact EQUASIS Secretariat to resolve any technical issues that might be currently hampering the use of CAS data supplied by IMO.

## **15 FOLLOW-UP TO UNCED AND WSSD**

15.1 The Committee noted that, under this item, the Committee was normally invited to note developments of the marine environment sector in relation to the Plan of Implementation adopted at the World Summit on Sustainable Development (WSSD), which was held in 2002 in Johannesburg, South Africa.

15.2 The Committee, recognizing that there had been many positive developments in many countries since the 2002 WSSD, invited Members to provide information concerning the work of the MEPC to future sessions of the Committee.

## **16 TECHNICAL CO-OPERATION PROGRAMME**

16.1 The Committee recalled that, given the importance of technical co-operation in the work of the Organization, MEPC 51 decided that the Committee should have technical co-operation on its agenda on a regular basis; the even-numbered sessions providing exhaustive reports on the Organization's marine environment-related technical co-operation activities and updates provided, whenever necessary, at odd-numbered sessions. In keeping with this practice, the Committee was provided with a full report on the marine environment-related activities implemented under the Integrated Technical Co-operation Programme (ITCP) for 2004-2005.

16.2 The Committee noted that four documents were submitted by the Secretariat under this agenda item, namely: MEPC 54/16, MEPC 54/16/1, MEPC 54/16/2 and MEPC 54/16/3, which provided an update on the national and regional activities under the ITCP during the biennium 2004-2005 and on the implementation of the Protocol to the Barcelona Convention concerning co-operation in combating pollution in the Mediterranean Sea by oil and other harmful substances in cases of emergency. They also provided information on the activities carried out during 2004-2005 under the major projects/programmes financed through outside sources. In this respect, the Committee took note of the developments regarding:

- .1 the project on building Partnerships for Environmental Protection and Management of the Seas of East Asia (PEMSEA);
- .2 the project on Removal of Barriers to the Effective Implementation of Ballast Water Control and Management Measures in Developing Countries (GloBallast);
- .3 the project on the assessment of the extent of aquatic species transfer through ships' ballast water and sediments into and out of the Caspian Sea;
- .4 the Marine Electronic Highway (MEH) Project; and
- .5 the project on EUROMED Co-operation on Maritime Safety and Prevention of Pollution from Ships (SAFEMED).

16.3 The Committee also took note of the information provided by the Secretariat on major projects being developed and which included activities to be implemented directly by IMO or under its supervision.

16.4 In considering the documents submitted, the Committee noted the important role played by workshops and training courses in catalyzing or strengthening the co-operation between national Authorities of any given region and between Governments and industry in the field of preparedness and response. The importance of such co-operation in ensuring viable response systems was also emphasized.

16.5 The Committee further noted the good co-operation between IMO and the oil Industry, through the International Petroleum Industry Environmental Conservation Association (IPIECA) within the framework of the IMO/Industry Global Initiative, which aims at achieving global ratification and effective implementation and enforcement of the OPRC Convention 1990. Information on the newly developed project for the benefit of the West and Central African (WACAF) countries was also provided to the Committee.

16.6 In the field of pollution prevention, the Committee's attention was drawn to the good results achieved in the ratification and implementation of the relevant IMO Conventions. With regards to MARPOL, it was recognized that particular attention should be given in the IMO technical co-operation programme to enhance the level of ratification and effective implementation, with emphasis on global provision of adequate port reception facilities.

16.7 The Committee also noted that the new ITCP for 2006-2007 was being implemented as a continuation of actions initiated under the previous programme and included new activities, some of which dealing with the ratification and implementation of the OPRC-HNS Protocol 2000, including provisions for the running of OPRC-HNS training courses.

16.8 The Committee's attention was drawn to the relentless effort of the Secretary-General and indeed of the Secretariat as a whole to seek financial contributions for the funding of the technical co-operation activities of the Organization. Members were invited to give priority to the funding of the technical co-operation programme by recognizing the shared responsibility for fund raising and to look into ways and means to donate or indeed increase their contributions to the IMO technical co-operation programme, both in-cash and/or in-kind.

16.9 The Director of the Technical Co-operation Division (TCD) provided the Committee with additional information on the Organization's technical co-operation programme. In his address, he recalled the importance of technical co-operation in the work of the Organization; this explaining the choice of the theme for this year's World Maritime Day: "Technical Co-operation – IMO's response to the 2005 World Summit" with special emphasis on the maritime needs of Africa. He informed the Committee on the relatively important level of funding for the marine environment – related activities under the current ITCP for 2006-2007.

16.10 The Committee further noted the level of support of the ITCP by the Technical Co-operation (TC) Fund and the rather critical financial situation being experienced with the current biennium, which was allocated funding, equalling some 71% only of the TC Fund allocation for the previous biennium 2004-2005; this resulting directly from the diminution of the surplus of the IMO Printing Fund.

16.11 The Director of TCD reiterated the shared responsibility for fund-raising, which should be the worry of everyone concerned and not that of the IMO secretariat only. In this respect, he

made reference to relevant articles and resolutions contained in a number of IMO Conventions advocating the promotion of technical co-operation. He further recalled the very good results achieved by the Marine Environment Division in securing funding for the marine environment-related activities through the Global Environment Facility (GEF) and other donors.

16.12 The Committee reiterated its commitment to technical co-operation and the importance that it attaches to it. In commenting on the documents, a number of delegations expressed their appreciation for a comprehensive and cohesive report and also for the technical assistance provided by the Organization. The Committee was informed of on-going projects and of the benefits derived from them by the relevant countries for the further development of their maritime infrastructures. In particular, the Committee noted:

- .1 the need for some feedback on the impact of the programs as far as the vision and priority objectives of the Committee are concerned. In this respect, the Committee further noted the existence in IMO of tools for measuring the impact of technical assistance on individual countries, which includes the evaluation of individual courses, seminars and workshops by participants during, at the end and six to seven months after each event. On a broader scale, regular impact assessment exercises on the ITCP are also undertaken by the Secretariat and reported back to the Technical Co-operation Committee;
- .2 the need to ensure a minimal period of bondage to the relevant Government service, in cases where personnel have been trained with ITCP resources; such bondage aiming at ensuring that the knowledge acquired is effectively utilized. The individual countries' priorities are identified as a deciding factor, which might constitute a major impediment to achieving such bondage period;
- .3 the need to get the oil industry to make generous donations for the funding of the ITCP; and
- .4 in relation to the revised MARPOL Annex II, the need to make provisions for technical co-operation activities to facilitate its implementation taking account of its entering into force in January 2007.

16.13 In summing up, the Chairman acknowledged the importance of technical co-operation in the work of the Organization and, recognizing that it was teamwork, expressed his appreciation to all the IMO Divisions for their hard work and especially the Marine Environment Division, which was responsible for the bulk of the marine environment-related technical co-operation activities.

## **17 FUTURE ROLE OF FORMAL SAFETY ASSESSMENT AND HUMAN ELEMENT ISSUES**

### **Formal Safety Assessment**

17.1 The Committee recalled the decisions made at MEPC 53, having considered the report of the FSA Correspondence Group and the outcome of MSC 80 on FSA matters, as reported in document MEPC 53/24, paragraph 19.17, including dissemination of MSC/Circ.1180 – MEPC/Circ.474 on amendments to the Guidelines for formal safety assessment for use in the IMO rule-making process (MSC/Circ.1023 – MEPC/Circ.392).

17.2 The Committee noted that MSC 81 was due to establish a drafting group on Formal Safety Assessment, and that the group's outcome and the subsequent decisions by MSC 81 would be submitted to MEPC 55 for appropriate action.

### **Human Element issues**

17.3 The Committee recalled that MEPC 53, consistent with its agreement with the MSC that the Joint MSC/MEPC Working Group on the Human Element should meet once a year at alternate sessions of the MSC and MEPC, established the Joint Working Group to consider human element issues, including development of the Organization's strategy in this respect. It also recalled that, having considered the report of the group, MEPC 53 approved, subject to concurrent decision of the MSC, five draft MSC/MEPC circulars on:

- .1 checklist for considering human element issues by IMO bodies (MEPC 53/WP.12, annex 1);
- .2 strengthening of human element input to the work of IMO (MEPC 53/WP.12, annex 2);
- .3 framework for IMO consideration of ergonomics and work environment (MEPC 53/WP.12, annex 3);
- .4 the Organization's strategy to address the human element (MEPC 53/WP.12, annex 4); and
- .5 guidelines on the basic elements of a shipboard occupational health and safety programme (BLG 9/17, annex 7), as amended by the Committee (MEPC 53/24, paragraphs 19.29 and 19.20).

17.4 The Committee noted that the five MSC/MEPC circulars listed above would be disseminated after concurrent approval by MSC 81.

17.5 The Committee noted also that the Joint MSC/MEPC Working Group on the Human Element would be reconvened during MSC 82 and that the Group's outcome and the subsequent decisions by MSC 82 would be submitted to MEPC 56 in 2007, for appropriate action.

## **18 WORK PROGRAMME OF THE COMMITTEE AND SUBSIDIARY BODIES**

### **The Organization's Strategic Plan, High Level Action Plan and Priorities**

18.1 The Committee, noting that the Organization's Strategic Plan, High Level Action Plan and Priorities had been dealt with under item 11 in conjunction with the outcome of the Assembly and the Council (see paragraphs 11.5 to 11.7), agreed to take all necessary actions under relevant items of the Committee's agenda in accordance with the decisions of the Assembly and the Council.

### **Work programmes of the relevant Sub-Committees**

18.2 The Committee recalled that MEPC 53 approved the work programme of BLG and FSI Sub-Committees, including the provisional agendas for BLG 10 and FSI 14 on the basis of those approved by MSC 80 (MEPC 53/24, paragraph 20.21 and annex 34).

18.3 The Committee recalled also that, having noted the information provided on the work programme of the DSC, NAV, DE, SLF and STW Sub-Committees at its last session (MEPC 53/20/5) and the decision of MSC 80 (MSC 80/24, annexes 18 and 19), MEPC 53 amended and approved the items on the work programme of the aforementioned Sub-Committees, which related to environmental issues (MEPC 53/24, paragraph 20.22 and annex 35).

18.4 The Committee concurred with the suggestion of the Chairman that, as these Sub-Committees had not met, except for the DE Sub-Committee which met in February 2006, since the work programmes of the aforementioned Sub-Committees had been approved by MEPC 53, consideration of their work programmes or provisional agendas would be dealt with at MEPC 55 (October 2006) after MSC 81 (May 2006).

18.5 In this connection, the Committee noted that the MSC was expected to establish the Joint MSC/MEPC Working Group on Human Element at MSC 82 (December 2006) (see paragraph 17.5).

#### **Items to be included in the agenda of the Committee's forthcoming three sessions**

18.6 The Committee approved the items to be included in the agendas for MEPC 55, MEPC 56 and MEPC 57 (MEPC 53/WP.2), which are set out at annex 21.

#### **Dates for MEPC 55, MEPC 56 and MEPC 57**

18.7 The Committee noted that MEPC 55 would be held from 9 to 13 October 2006 and that MEPC 56 and MEPC 57 were scheduled tentatively in July 2007 and March 2008, respectively.

#### **Working/review/drafting groups at MEPC 55**

18.8 The Committee agreed, in principle, to establish the following working/review/drafting groups at MEPC 55:

- .1 Review Group on Ballast Water Treatment Technologies;
- .2 Working Group on Ship Recycling;
- .3 Working Group on Air Pollution; and
- .4 Drafting Group on Amendments to Mandatory Instruments.

#### **Correspondence group**

18.9 The Committee agreed to establish the Correspondence Group on Ship Recycling (see paragraph 3.22.6), which should report to MEPC 55.

#### **Intersessional meetings**

18.10 The Committee agreed to hold the following intersessional meetings:

- .1 Working Group on the Revision of MARPOL Annex VI under the BLG Sub-Committee to be held before the end of 2006, which should report to BLG 11;



- .2 ESPH Working Group (ESPH 12) to be held in September 2006, which was requested to report directly to MEPC 55 on items as identified by BLG 10; and
- .3 OPRC-HNS Technical Group to be held during the week prior to MEPC 55 in October 2006, which should report to MEPC 55.

## **19 APPLICATION OF THE COMMITTEES' GUIDELINES**

19.1 The Committee recalled that the last Chairmen's Meeting was held on 14 May 2005 to address outstanding issues from its previous Chairmen's meeting in 2004, including the terms of references of the sub-committees, improving efficiency of meetings, control of new work programme items and workload management, among others. The report of the Chairmen's Meeting was considered by MSC 80 and MEPC 53.

19.2 The Committee also recalled that, at MEPC 53, the delegation of the Marshall Islands raised an issue concerning paragraph 19.2 of the Report of the Chairmen's Meeting (MEPC 53/21/1) on the timely availability of session documents on the IMODOCS website, and MEPC 53 noted that this issue would be considered at the next Chairmen's meeting (MEPC 53/24, paragraph 21.8).

19.3 The Chairman informed the Committee that the next Chairmen's meeting would be held in May 2006 in conjunction with MSC 81 and the outcome of that meeting would be brought to the attention of MEPC 55.

19.4 The Chairman reminded the Committee that the majority of documents for this session of the Committee were submitted just on the deadlines. While this was acceptable in accordance with the Committee's Guidelines, it would be highly appreciated if, for future sessions of the Committee, delegations could make their submissions as early as possible in order to allow more time for other delegations to study the submissions and to facilitate discussions during the meeting. Also, in view of the move of the IMO Secretariat to Victoria Street, London, in July 2006 and although utmost efforts would be made to ensure the smooth running of IMO meetings, potential disruptions on work flow could not be ruled out. Therefore, the early submission of documents could compensate for any such disruptions.

19.5 The Chairman, recalling the establishment the Technical Group on PSSAs and Special Areas at this session and the views of some delegations in preference of a working group, stated that the method of work of this Committee was no longer in alignment with the Maritime Safety Committee regarding its subsidiary bodies in accordance with the Guidelines on the Organization and Method of Work of the MSC and the MEPC and their subsidiary bodies as amended (MSC/Circ.1099 – MEPC/Circ.405).

19.6 The Chairman reminded the Committee that, under the Committees' Guidelines, only working groups, drafting groups and correspondence groups are mentioned. However, during its recent sessions, the Committee established technical groups (i.e., Technical Group on PSSAs and Special Areas and the OPRC-HNS Technical Group) and a Ballast Water Technology Review Group, which had not been considered in the Guidelines.

19.7 Accordingly, the Committee agreed to the Chairman's proposal that he and the Secretariat would prepare a document regarding the inclusion in the Committee's Guidelines of technical groups and review groups, which may be applicable only to this Committee, to be submitted to MEPC 55 for consideration.

## 20 ANY OTHER BUSINESS

### **Outcome of the Children's World Summit held in Aichi, Japan, held from 26 to 29 July 2005 (MEPC 54/20)**

20.1 The Committee, having recalled the Secretary-General's remarks at MEPC 53 on the value and importance of highlighting IMO's role in protection of the marine environment to the younger generation, noted IMO's role in facilitating the attendance of children at the Children's World Summit for the Environment, which was held in Aichi, Japan from 26 to 29 July 2005.

20.2 The Committee also noted that the Children's World Summit was considered a great success and that as a result of IMO's initiative, four children had presented messages on behalf of IMO and the Junior sectors of the Marine Environment Protection Associations (MEPAs) in the Mediterranean Sea region, to the Children's Summit as "Ambassadors of IMO for the Protection of the Marine Environment". The four MEPA children were Nikolas Adami, sponsored by CYMEPA Junior, Nikolaos Theofilidis from Greece, sponsored by HELMEPA Junior and Çagla Gamze Seten and Beril Esen from Turkey, sponsored by TURMEPA Junior.

20.3 The Committee further noted that the initiative generated much interest in the MEPA Junior concept and that it would encourage the establishment of more Junior MEPAs in the future, in other regions of the world.

20.4 The delegation of Greece, in referring to document MEPC 54/20 (Secretariat), congratulated the Secretary-General and the Chairman for their work in promoting the role of the younger generation in the protection of the marine environment. Furthermore, they thanked all in the Committee for providing the opportunity to the four children from the Junior sectors of HELMEPA, CYMEPA and TURMEPA to represent IMO in this global event as "Ambassadors of the IMO for the Protection of the Marine Environment".

20.5 The delegation of Greece stated that it was their strong belief that such initiatives make the younger generation the most effective couriers of sound environmental messages, while bringing the children closer to shipping thus broadening their future career horizons. By promoting the issue of Environmental Awareness in Youth, through IMO, the international maritime community showed the world their concern for the health of the marine environment.

20.6 The delegation of Greece further stated that it was important that MEPC maintains the momentum by projecting this noble cause. A step in this direction could be for IMO to place under its auspices a global Junior Drawing Competition, the winning drawing of which could be for example printed in the form of a poster and disseminated by MEPC delegations in order to project the common message worldwide.

20.7 They further informed the Committee that in recent joint meetings of INTERMEPA, the Boards of the three Mediterranean MEPAs, HELMEPA, CYMEPA and TURMEPA had decided to strengthen even further the co-operation between their Junior sectors, whilst co-operation continued with AUSMEPA in Australia, PHILMEPA in the Philippines and URUMEPA in Uruguay. Moreover, interest had been expressed recently for the founding of similar non-governmental, non-profit Associations – MEPAs in the Middle East, the Far East and the Black Sea region.

20.8 In concluding, the Greek delegation urged delegations to the Committee to take this issue to heart and give the children a chance to learn, to share ideas and above all, avoid mistakes made by the older generation in their pursuit of development and prosperity.

20.9 The delegation of Uruguay thanked HELMEPA for its work, particularly, for increasing environmental consciousness among young people as well as those who are not that young.

**Information regarding Australian studies of marine debris and an investigation of biofouling risks and management options on commercial vessels**

20.10 The Committee noted with appreciation the information provided by Australia (MEPC 54/INF.4 and Corr.1) on “Australian studies of marine debris” and emphasized the importance of effective implementation of MARPOL Annex V which prohibits the discharge of plastics at sea. The Committee invited other delegations to provide similar information to future sessions of the Committee.

20.11 The Committee, having noted that the information provided by Australia (MEPC 54/INF.5) on “Investigating biofouling risks and management options on commercial vessels” was relevant to the AFS Convention, thanked Australia and invited Members to submit documents to further sessions of the Committee under the item on “Harmful anti-fouling systems for ships”.

\*\*\*



**ANNEX 1**

**RESOLUTION MEPC.140(54)**

**Adopted on 24 March 2006**

**GUIDELINES FOR APPROVAL AND OVERSIGHT OF PROTOTYPE BALLAST  
WATER TREATMENT TECHNOLOGY PROGRAMMES (G10)**

THE MARINE ENVIRONMENT PROTECTION COMMITTEE,

RECALLING Article 38(a) of the Convention on the International Maritime Organization concerning the functions of the Marine Environment Protection Committee conferred upon it by the international conventions for the prevention and control of marine pollution,

RECALLING ALSO that the International Conference on Ballast Water Management for Ships held in February 2004 adopted the International Convention for the Control and Management of Ships' Ballast Water and Sediments, 2004 (the Ballast Water Management Convention) together with four Conference resolutions,

NOTING that regulation A-2 of the Ballast Water Management Convention requires that discharge of ballast water shall only be conducted through Ballast Water Management in accordance with the provisions of the Annex to the Convention,

NOTING FURTHER that regulation D-4.3 of the Ballast Water Management Convention provides that, in establishing and carrying out any programme to test and evaluate promising Ballast Water technologies, Parties shall take into account Guidelines developed by the Organization,

NOTING ALSO that resolution 1 adopted by the International Conference on Ballast Water Management for Ships invited the Organization to develop these Guidelines as a matter of urgency,

HAVING CONSIDERED, at its fifty-fourth session, the draft Guidelines for approval and oversight of prototype ballast water treatment technology programmes developed by the Ballast Water Working Group,

1. ADOPTS the Guidelines for approval and oversight of prototype ballast water treatment technology programmes as set out in the annex to this resolution;
2. INVITES Governments to apply the Guidelines as soon as possible, or when the Convention becomes applicable to them; and
3. AGREES to keep the Guidelines under review.

ANNEX

**GUIDELINES FOR APPROVAL AND OVERSIGHT OF PROTOTYPE BALLAST  
WATER TREATMENT TECHNOLOGY PROGRAMMES (G10)**

**Content**

**1 INTRODUCTION**

General  
Purpose  
Applicability  
Programme requirements

**2 DEFINITIONS**

**3 PROGRAMME APPLICATION REQUIREMENTS**

Participants  
Ballast water treatment technology description  
Ship description  
Installation and installation survey description  
Performance test and evaluation description  
Time schedule and reporting

**4 INSTALLATION SURVEY AND STATEMENT OF COMPLIANCE**

Installation survey  
Statement of Compliance

**5 PERFORMANCE REQUIREMENT FOR ALREADY INSTALLED SYSTEMS**

**6 PROGRAMME OVERSIGHT**

**APPENDIX**

**Statement of Compliance for a Prototype Ballast Water Treatment Technology**

## **GUIDELINES FOR APPROVAL AND OVERSIGHT OF PROTOTYPE BALLAST WATER TREATMENT TECHNOLOGY PROGRAMMES (G10)**

### **1 INTRODUCTION**

#### **General**

1.1 These Guidelines provide recommendations for Administrations on the approval and oversight of programmes for prototype ballast water treatment technologies in accordance with regulation D-4 of the “International Convention for the Control and Management of Ships’ Ballast Water and Sediments, 2004” (the Convention). The intention of regulation D-4 is to provide opportunities to test and evaluate promising ballast water treatment technologies aboard ships with the potential to meet or exceed the performance standards in regulation D-2 of the Convention. The document may also assist manufacturers, ship owners and other stakeholders undertaking development activities in the area of ballast water treatment. The Guidelines also make recommendations on criteria for approval of such programmes. Recommendations outlined in these Guidelines should be applied in an objective, consistent and transparent way and their application should be evaluated periodically by the Organization.

1.2 Regulations referred to in these Guidelines are those contained in the Convention.

1.3 The Guidelines include general recommendations on design and construction, technical procedures for overall performance testing and evaluation, procedures for the issuance of a Statement of Compliance in accordance with regulation D-4 and Administration oversight responsibilities.

1.4 As the level of ballast water management knowledge, experience and subsequently technological achievements continue to develop, these Guidelines may require updating. Periodical review of their content in light of such developments should be carried out and any revisions duly circulated by the Organization.

#### **Purpose**

1.5 The main purpose of these Guidelines is to:

- .1 assist Administrations to approve or reject proposed programmes and in cases where approval is granted, to issue a Statement of Compliance under regulation D-4;
- .2 describe the responsibilities of the Administration in the oversight of the programme’s execution; and
- .3 encourage a uniform interpretation and application of regulation D-4.

## Applicability

1.6 These Guidelines apply to programmes established to test and evaluate promising ballast water treatment technologies in accordance with regulation D-4.

## Programme requirements

1.7 The Programme for prototype ballast water treatment technologies in accordance with these Guidelines should contain the following three main steps:

- .1 **Programme Application, Submission and Approval:** The submission should include a detailed plan describing the prototype technology and implementation of the programme as described in Section 3. Further, the applicant should include evidence on the potential of the prototype technologies meeting or exceeding the performance standard in regulation D-2. If the prototype ballast water treatment technology makes use of Active Substances, or preparations containing one or more Active Substances, the substances should have received Basic Approval, as described by the Procedure for the Approval of Ballast Water Management systems that make use of Active Substances (G9). All of the above information should be the basis for the Administration in its evaluation and approval of the submitted programme. In the case where a programme is approved, the applicant may proceed in accordance with the approved programme taking into account any conditions set by the Administration.
- .2 **Installation Survey and Statement of Compliance:** The installation of the prototype ballast water treatment technology in accordance with the approved Programme should be verified by an installation survey. Provided that this survey confirms adherence to the approved programme, including any applicable conditions set by the Administration, a Statement of Compliance under regulation D-4 may be issued by the Administration.
- .3 **Performance Evaluations and Reporting:** During the test and evaluation period, a prototype ballast water treatment technology should be subjected to on-going experimental testing and evaluation according to the approved programme to evaluate both the engineering and biological performance under shipboard operating conditions. Reporting to the Administration should be of the form and schedule in accordance with the approved programme.

## 2 DEFINITIONS

2.1 Prototype Ballast Water Treatment Technology - means any integrated system of ballast water treatment equipment as under regulation D-4, participating in a programme for testing and evaluation with the potential of meeting or exceeding the ballast water performance standard in regulation D-2 including treatment equipment, all associated control equipment, monitoring equipment and sampling facilities. A prototype ballast water treatment technology may be a mechanical, physical, chemical, or biological unit process, either singularly or in combination that may or may not use Active Substances that remove, render harmless, or avoid the uptake or discharge of Harmful Aquatic Organisms and Pathogens within ballast water and sediments.



Prototype ballast water treatment technologies may operate at the uptake or discharge of ballast water, during the voyage or in any combination of these phases.

2.2 Ballast Water Management Plan - is the document referred to in regulation B-1 of the Convention describing the ballast water management processes and procedures on board individual ships.

2.3 Active Substances - means a substance or organism, including a virus or a fungus that has a general or specific action on or against Harmful Aquatic Organisms and Pathogens.

2.4 Control Equipment - refers to the installed equipment required for proper functioning of the prototype ballast water treatment technology.

2.5 Monitoring Equipment - refers to the equipment installed for assessment of the correct operation of the prototype ballast water treatment technology.

2.6 Convention - means the International Convention for the Control and Management of Ships' Ballast Water and Sediments, 2004.

2.7 Sampling Facilities - refers to the means provided for sampling treated or untreated ballast water as needed in these Guidelines.

### **3 PROGRAMME APPLICATION REQUIREMENTS**

3.1 This section provides the detailed elements and documentation that should be included in a Programme and Programme Application as defined in section 1.7.1. The Programme Application should contain information on the following aspects:

- .1 participants
- .2 ballast water treatment technology description
- .3 ship description
- .4 installation and installation survey description
- .5 performance test and evaluation description
- .6 time schedule and reporting

3.2 All relevant and requested documentation describing the Programme for which the applicant is applying for approval should be submitted to the Administration. The application should only encompass one prototype ballast water treatment technology and should not normally result in installations in more than three ships. Prototype installations onboard more than one ship should be justified in the application and may rest upon technology development requirements related to, for example:

- capacity issues;
- geographical areas of operation;
- specific onboard conditions varying as a function of ship type; and
- refit to existing vessels versus installations onboard new vessels.

3.3 The Programme Application should also take into account safety and environmental regulations which have to be met by the ship so as to ensure that other international and/or national requirements are not compromised by the prototype ballast water treatment technology.

3.4 The Programme should implement appropriate quality control measures in accordance with recognized international standards to which all participants specified in Section 3.5 should be required to comply.

### **Participants**

3.5 The Programme should provide an overview of the different participants included in the Programme Application including, as appropriate:

- the ship owner or operator;
- the manufacturer(s); and
- the testing institution or any laboratories, institution(s) or companies carrying out elements of or the entire programme or advising the manufacturer in carrying out the programme.

3.6 The roles and responsibilities of each of the identified participants should be clearly described within the Programme Application.

### **Ballast water treatment technology description**

3.7 The Programme Application should include information regarding design, construction, operation and functioning of the proposed ballast water treatment technology. The information should also include any foreseen conditions limiting its application with respect to voyage duration, ship type, capacity (flow rate and/or volume) or any other such condition if relevant.

3.8 The Programme Application should contain documentation on the potential of the prototype technologies meeting or exceeding the performance standard in regulation D-2. Recognized scientific and statistical practices should have been utilized in the preparation of this documentation.

3.9 The construction, operation and maintenance of the technology should be adequately described to allow for consideration by the Administration and this should include:

- .1 The prototype ballast water treatment technology should have a configuration and construction suitable for shipboard installation and normal onboard operation;
- .2 Design, construction and material should be suitable for the purpose for which the equipment is intended, the working conditions to which it should be subjected and the environmental conditions onboard. This should include considerations of:
  - .1 vibration – to ensure that there are no potential resonance occurring;
  - .2 temperature – to assure safe and proper operations and performance of the technology over a range of temperatures applicable for shipboard installations;

- .3 humidity – to ensure the suitability of equipment exposed to humidity/water as applicable to shipboard installations;
  - .4 power fluctuation – to ensure proper functioning over a voltage/frequency variation; and
  - .5 inclination – to assure that the technology should operate during those scenarios it is intended for, taking into account the motion of the vessel and that it should remain safe and not represent any danger to crew or ship onboard during inclination.
- .3 Routine maintenance of the prototype ballast water treatment technology and trouble-shooting procedures should be clearly described by the manufacturer in a operating and maintenance manual.
  - .4 The prototype ballast water treatment technology should be provided with simple and effective means for its operation and control.
  - .5 In case of a failure compromising the proper operation of the prototype ballast water treatment technology, audible and visual alarm signals are to be activated at all stations from where ballast water operations may be controlled.
  - .6 The prototype ballast water treatment technology programme should provide for record keeping of the entire ballast water operations including:
    - .1 record of operations and any malfunctioning during operations;
    - .2 record of all essential parameters necessary to ensure proper functioning;
    - .3 date and time of start and end of the ballast operation; and
    - .4 ballast operation mode (loading, discharge, transfer).
  - .7 The prototype ballast water treatment technology should allow for sampling such that representative samples of the ship's ballast water can be collected as described in the experimental design as described in the Programme Application.

3.10 The Programme Application should include descriptions of the working principles, use if any Active Substances, operational conditions and application feasibility of the prototype ballast water treatment technology.

3.11 The Programme Application should include an assessment of the potential effects upon other personnel, shipboard systems and structure, highlighting any special safety provisions that maybe necessary due to the characteristics of the installation and/or operation of the prototype ballast water treatment technology.

### **Ship description**

3.12 The Programme Application should include a full and complete description of the ship(s) in which the prototype ballast water treatment technology is to be installed. This description should include:

- ships' name;
- date of construction;
- flag;
- port of registry;
- gross tonnage;
- dead weight;
- IMO number;
- length (bp);
- beam;
- international call sign;
- deepest ballast drafts (normal and heavy weather);
- total ballast capacity of the ship in cubic metres and other units if applicable to the ship.

3.13 The description should also include normal operational ballast flow rates and volumes, and, to the extent possible, typical voyage lengths and routes.

### **Installation and installation survey description**

3.14 The Programme Application should fully describe the manner in which the equipment should be integrated into the ship and should provide the following for the onboard installation:

- .1 process flow diagram of the prototype ballast water treatment technology;
- .2 "equipment arrangement" drawings of the proposed prototype ballast water treatment installation. These should show scaled lay-outs of the spaces and important mechanical and structural features such as major propulsion and electrical components, bulkheads and pillars, and doors and other means of access/egress;
- .3 "piping arrangement" drawing of the prototype ballast water treatment system installation, including ballast and cross-connected piping systems, sample piping, and the operational outlets for treated effluent and any waste streams;
- .4 information relating to onboard safety matters;
- .5 an assessment of the potential effects upon other shipboard systems and the ship's structure, highlighting those aspects of the design and operation of the system, and its integration into the ship, to be put in place to prevent any compromises to crew and ship safety;

- .6 assurance of adequate safety interlocks and failsafe measures to ensure subdivision boundaries, structural integrity, and vessel stability are not compromised;
- .7 assurance that new piping and flows should not result in unsafe ballasting or deballasting situations, e.g., overpressure;
- .8 assurance that escape arrangements in manned spaces are not compromised;
- .9 arrangements for maintaining the integrity any boundary between safe and hazardous spaces;
- .10 attention to restrictions related to the use of electrical equipment in hazardous areas; and
- .11 a provision for safe storage and use of Active Substances.

3.15 The installation survey description should contain a listing of those items which should be validated at the survey and these include, as a minimum, the following:

- .1 updated, as-installed diagrammatic drawings of any additional pumping and piping arrangements, identifying the operational outlets for treated effluent and any waste streams. Special consideration may have to be given to installations on ships that have unusual pumping and piping arrangements, as well as restrictions related to the use of electrical equipment in hazardous areas;
- .2 equipment manuals, supplied by manufacturers, which should contain details of the major components of the treatment system;
- .3 operations and technical manual for the complete installed prototype ballast water treatment. This manual should cover the arrangements and operation of the system as a whole and should specifically describe the parts of the system which may not be covered by the manufacturer's equipment manuals. The operations section of the manual should include normal operational procedures and procedures for the discharge of untreated water in the event of malfunction of the equipment. The technical section of the manual should include adequate information (description and diagrammatic drawings of the pumping and piping arrangements, of the monitoring system and electrical/electronic wiring diagrams) to enable fault finding and should include instructions for keeping a maintenance record;
- .4 the installation should comply with manufacturer's specific installation criteria. A technical installation specification defining, *inter alia*, the location and mounting of components, arrangements for maintaining the integrity of any boundary between safe and hazardous spaces, and the arrangement of the sample piping;
- .5 the Ballast Water Management Plan; and

- .6 any other conditions required by the Administration.

3.16 The Programme Application should provide a recommended test and survey procedure. This procedure should specify all the checks to be carried out in a functional test and should provide guidance for the surveyor when carrying out the on-board survey of the treatment system. This procedure may be amended as necessary prior to the survey and with the concurrence of the Administration.

### **Performance test and evaluation description**

3.17 A full description of the onboard tests and evaluations to be undertaken should be provided. When available standard methods for the collection, handling (including concentration), storage, and analysis of samples should be applied. These methods should be clearly referenced and described in test plans and in reports. This includes methods for detecting, concentrating, enumerating, and identifying organisms and for determining viability. When non-standard methods are used they should be validated, documented and reported. A description of the experimental design and sampling procedure should be provided.

3.18 The Programme should evaluate:

- .1 the biological efficacy of the installed prototype ballast water treatment technology;
- .2 the operational performance which should include, but not be limited to:
  - unplanned maintenance and manning requirements
  - operational data relative to manufacturer's specification
  - consideration of the environmental conditions identified in section 3.9.2;
- .3 the effects upon the ship's systems and structure; and
- .4 any other characteristics identified by the participants or the Administration.

3.19 Experimental Design and Protocols should include:

- .1 a general description of the experimental test including the experimental hypotheses being tested and methods for the determination of biological efficacy and operational performance. The Programme Application should identify the test locations, source waters, and relevant environmental water conditions, to the extent possible. The overall study plan should take full advantage of the range of locations provided by the vessel's operations, to the extent practicable;
- .2 a detailed description for each of the experiments including:
  - .1 ballast water sample collection for each treatment and control, identification and number of replicate tanks, ballast water samples and time points encompassed in the test;

- .2 description of test runs: replicate tests (tests at same location and environmental conditions) and comparative tests (tests at different locations or environmental conditions). Description of how the efficacy of the treatment process should be evaluated; include a description of how the efficacy should be quantified, as well as a description of the comparison of biological efficacies;
  - .3 the plan should address statistical analysis (including power analysis) and data confidence issues. Fully describe the intended statistical tests, use of controls, and replicates for each experiment; and
  - .4 how the experiment accounts for the range of seasons, organic matter content, turbidity, pH, salinity, etc. likely to be encountered in operation and, to the extent possible, describe the range of these variables;
- .3 the experimental design should address the operation of the ship's systems whose arrangements (e.g., cross connections) have the potential to confound the resulting data.

### **Time schedule and reporting**

3.20 The Programme Application should include procedures and schedules for reporting the progress and status of the Programme through all phases. Reporting to the Administration should occur on a regular basis throughout the Programme. In addition, reporting should include the results and evaluation of all conducted experiments.

3.21 The Programme Application should present an overall time schedule compliant with project management standards. This schedule should include an estimation of major task element time lines. Each of these should have an anticipated period of performance and execution and include events such as approval of the Programme by the Administration, the installation survey, experimental and progress reports. Major task elements should include the installation of the prototype ballast water treatment technology into the ship, initiation and execution of experiments and maintenance periods.

## **4 INSTALLATION SURVEY AND STATEMENT OF COMPLIANCE**

### **Installation survey**

4.1 Following approval of the Programme Application, the Programme may proceed to installing the onboard prototype ballast water treatment technology.

4.2 Following installation a survey should be performed by the Administration, or any designated body appointed by the Administration to act on its behalf, to verify that the system installation has been carried out in accordance with the approved Programme and that the workmanship of the installation is satisfactory.

### **Statement of Compliance**

4.3 Upon successful completion of the Installation Survey a Statement of Compliance may be issued by the Administration, or by a person or organization duly authorized by the Administration. In every case, the Administration assumes full responsibility for the Statement of Compliance. The recommended format for the Statement of Compliance is given in the Appendix.

4.4 The Statement of Compliance should be valid until five years after the dates specified in regulations D-4.1 and D-4.2, as appropriate.

## **5 PERFORMANCE REQUIREMENT FOR ALREADY INSTALLED SYSTEMS**

5.1 Ships with already installed prototype ballast water treatment technologies that wish to make use of the provision of regulation D-4, may do so provided that a Programme Application is approved by the Administration.

## **6 PROGRAMME OVERSIGHT**

6.1 The Administration or any designated body appointed by the Administration to act on its behalf should ensure that the Programme as approved is followed.

6.2 The Administration should revoke the Statement of Compliance if the ship fails to follow the approved Programme or otherwise does not comply with the conditions of regulation D-4.4.



## APPENDIX 1

### Statement of Compliance for a Prototype Ballast Water Treatment Technology

(Official seal)

Issued under the provisions of

GUIDELINES FOR APPROVAL AND OVERSIGHT OF PROTOTYPE BALLAST WATER  
TREATMENT TECHNOLOGY PROGRAMMES (G10)

(Resolution MEPC.140(54)),

under the authority of the Government of *(full designation of country)*

by *(full designation of the competent person or organization recognized by the Administration)*

#### Particulars of ship

Name of ship

IMO Number\*

Distinctive number or letters

Port of registry

Gross tonnage

Ballast Water Capacity, Volume and Flow Rates

Date on which keel was laid or ship was at a similar stage of construction or, (in the case of a converted ship) date on which conversion was commenced

Date by which the ship is required to comply with regulation D-2

Date on which the prototype ballast water treatment system was installed

Name and address of prototype ballast water treatment technology manufacturer

Trade name of technology

Serial number or other identifying marking

Name of Active Substance and details of Basic Approval

Brief description of the prototype technology

---

\* IMO Ship Identification Number Scheme adopted by the Organization by resolution A.600(15).

THIS IS TO CERTIFY:

1. That the ship has a prototype ballast water treatment system which is subject to a programme approved in accordance with regulation D-4 by the Government of (*insert Government title*) on (*insert date of approval of programme*).
2. That the prototype ballast water treatment technology installation has been surveyed in accordance with Section 4 of the annex to resolution MEPC.140(54).
3. A copy of the approved programme is on board the ship together with equipment, operations and maintenance manuals for the prototype ballast water treatment technology.

This Statement is valid until (*date*)

(Place of issue of Statement)

(Date of issue)

(Signature of authorized official issuing the Statement)

(Seal or stamp of the authority, as appropriate)

\*\*\*

**ANNEX 2**

**RESOLUTION MEPC.141(54)**

**Adopted on 24 March 2006**

**AMENDMENTS TO THE ANNEX OF THE PROTOCOL OF 1978 RELATING TO  
THE INTERNATIONAL CONVENTION FOR THE PREVENTION OF  
POLLUTION FROM SHIPS, 1973**

**(Amendments to regulation 1, addition to regulation 12A, consequential amendments  
to the IOPP Certificate and amendments to regulation 21 of the revised  
Annex I of MARPOL 73/78)**

THE MARINE ENVIRONMENT PROTECTION COMMITTEE,

RECALLING article 38(a) of the Convention on the International Maritime Organization concerning the functions of the Marine Environment Protection Committee (the Committee) conferred upon it by international conventions for the prevention and control of marine pollution,

NOTING article 16 of the International Convention for the Prevention of Pollution from Ships, 1973 (hereinafter referred to as the "1973 Convention") and article VI of the Protocol of 1978 relating to the International Convention for the Prevention of Pollution from Ships, 1973 (hereinafter referred to as the "1978 Protocol") which together specify the amendment procedure of the 1978 Protocol and confer upon the appropriate body of the Organization the function of considering and adopting amendments to the 1973 Convention, as modified by the 1978 Protocol (MARPOL 73/78),

NOTING ALSO that the revised Annex I to MARPOL 73/78 was adopted by resolution MEPC.117(52) and is expected to enter into force on 1 January 2007,

HAVING CONSIDERED proposed amendments to regulation 1, proposed new regulation 12A, consequential amendments to the Supplement (Forms A and B) of the IOPP Certificate, and proposed amendments to regulation 21 of the revised Annex I to MARPOL 73/78,

1. ADOPTS, in accordance with article 16(2)(d) of the 1973 Convention, the amendments to the revised Annex I of MARPOL 73/78, the text of which is set out at Annex to the present resolution;
2. DETERMINES, in accordance with article 16(2)(f)(iii) of the 1973 Convention, that the amendments shall be deemed to have been accepted on 1 February 2007, unless prior to that date, not less than one-third of the Parties or Parties the combined merchant fleets of which constitute not less than 50 per cent of the gross tonnage of the world's merchant fleet, have communicated to the Organization their objection to the amendments;
3. INVITES the Parties to note that, in accordance with article 16(2)(g)(ii) of the 1973 Convention, the said amendments shall enter into force on 1 August 2007 upon their acceptance in accordance with paragraph 2 above;

4. REQUESTS the Secretary-General, in conformity with article 16(2)(e) of the 1973 Convention, to transmit to all Parties to MARPOL 73/78 certified copies of the present resolution and the text of the amendments contained in the Annex; and

5. REQUESTS FURTHER the Secretary-General to transmit to the Members of the Organization which are not Parties to MARPOL 73/78 copies of the present resolution and its Annex.

ANNEX

**AMENDMENTS TO THE REVISED MARPOL ANNEX I**

**1 Addition of paragraph 28.9 to regulation 1**

The following new paragraph 28.9 is added after the existing paragraph 28.8 of regulation 1:

- “28.9 ship delivered on or after 1 August 2010 means a ship:
- .1 for which the building contract is placed on or after 1 August 2007; or
  - .2 in the absence of a building contract, the keels of which are laid or which are at a similar stage of construction on or after 1 February 2008; or
  - .3 the delivery of which is on or after 1 August 2010; or
  - .4 which have undergone a major conversion:
    - .1 for which the contract is placed after 1 August 2007; or
    - .2 in the absence of contract, the construction work of which is begun after 1 February 2008; or
    - .3 which is completed after 1 August 2010.”

**2 Addition of new regulation 12A on oil fuel tank protection**

*The following new regulation 12A is added after the existing regulation 12:*

**“Regulation 12A – Oil fuel tank protection**

- 1 This regulation shall apply to all ships with an aggregate oil fuel capacity of 600 m<sup>3</sup> and above which are delivered on or after 1 August 2010, as defined in regulation 1.28.9 of this Annex.
- 2 The application of this regulation in determining the location of tanks used to carry oil fuel does not govern over the provisions of regulation 19 of this Annex.
- 3 For the purpose of this regulation, the following definitions shall apply:
  - .1 “Oil fuel” means any oil used as fuel oil in connection with the propulsion and auxiliary machinery of the ship in which such oil is carried.
  - .2 “Load line draught (d<sub>s</sub>)” is the vertical distance, in metres, from the moulded baseline at mid-length to the waterline corresponding to the summer freeboard draught to be assigned to the ship.

- .3 “Light ship draught” is the moulded draught amidships corresponding to the lightweight.
  - .4 “Partial load line draught ( $d_p$ )” is the light ship draught plus 60% of the difference between the light ship draught and the load line draught  $d_s$ . The partial load line draught ( $d_p$ ) shall be measured in metres.
  - .5 “Waterline ( $d_B$ )” is the vertical distance, in metres, from the moulded baseline at mid-length to the waterline corresponding to 30% of the depth  $D_s$ .
  - .6 “Breadth ( $B_s$ )” is the greatest moulded breadth of the ship, in metres, at or below the deepest load line draught ( $d_s$ ).
  - .7 “Breadth ( $B_B$ )” is the greatest moulded breadth of the ship, in metres, at or below the waterline ( $d_B$ ).
  - .8 “Depth ( $D_s$ )” is the moulded depth, in metres, measured at mid-length to the upper deck at side. For the purpose of the application, “upper deck” means the highest deck to which the watertight transverse bulkheads except aft peak bulkheads extend.
  - .9 “Length ( $L$ )” means 96% of the total length on a waterline at 85% of the least moulded depth measured from the top of the keel, or the length from the foreside of the stem to the axis of the rudder stock on that waterline, if that be greater. In ships designed with a rake of keel the waterline on which this length is measured shall be parallel to the designed waterline. The length ( $L$ ) shall be measured in metres.
  - .10 “Breadth ( $B$ )” means the maximum breadth of the ship, in metres, measured amidships to the moulded line of the frame in a ship with a metal shell and to the outer surface of the hull in a ship with a shell of any other material.
  - .11 “Oil fuel tank” means a tank in which oil fuel is carried, but excludes those tanks which would not contain oil fuel in normal operation, such as overflow tanks.
  - .12 “Small oil fuel tank” is an oil fuel tank with a maximum individual capacity not greater than 30 m<sup>3</sup>.
  - .13 “C” is the ship’s total volume of oil fuel, including that of the small oil fuel tanks, in m<sup>3</sup>, at 98% tank filling.
  - .14 “Oil fuel capacity” means the volume of a tank in m<sup>3</sup>, at 98% filling.
- 4 The provisions of this regulation shall apply to all oil fuel tanks except small oil fuel tanks, as defined in 3.12, provided that the aggregate capacity of such excluded tanks is not greater than 600 m<sup>3</sup>.
- 5 Individual oil fuel tanks shall not have a capacity of over 2,500 m<sup>3</sup>.

6 For ships, other than self-elevating drilling units, having an aggregate oil fuel capacity of  $600 \text{ m}^3$  and above, oil fuel tanks shall be located above the moulded line of the bottom shell plating nowhere less than the distance  $h$  as specified below:

$$h = B/20 \text{ m or,}$$

$$h = 2.0 \text{ m, whichever is the lesser.}$$

The minimum value of  $h = 0.76 \text{ m}$

In the turn of the bilge area and at locations without a clearly defined turn of the bilge, the oil fuel tank boundary line shall run parallel to the line of the midship flat bottom as shown in Figure 1.

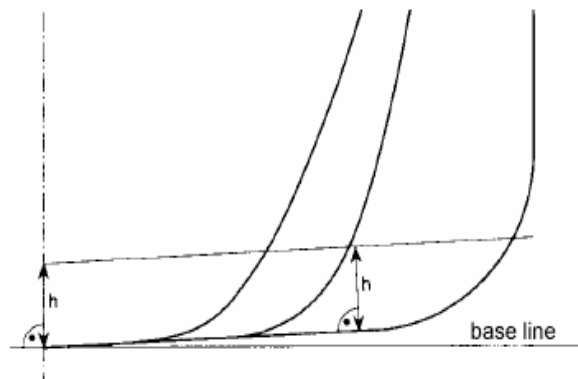

**Figure 1 – Oil fuel tank boundary lines for the purpose of paragraph 6**

7 For ships having an aggregate oil fuel capacity of  $600 \text{ m}^3$  or more but less than  $5,000 \text{ m}^3$ , oil fuel tanks shall be located inboard of the moulded line of the side shell plating, nowhere less than the distance  $w$  which, as shown in Figure 2, is measured at any cross-section at right angles to the side shell, as specified below:

$$w = 0.4 + 2.4 C/20,000 \text{ m}$$

The minimum value of  $w = 1.0 \text{ m}$ , however for individual tanks with an oil fuel capacity of less than  $500 \text{ m}^3$  the minimum value is  $0.76 \text{ m}$ .

8 For ships having an aggregate oil fuel capacity of  $5,000 \text{ m}^3$  and over, oil fuel tanks shall be located inboard of the moulded line of the side shell plating, nowhere less than the distance  $w$  which, as shown in Figure 2, is measured at any cross-section at right angles to the side shell, as specified below:

$$w = 0.5 + C/20,000 \text{ m or}$$

$$w = 2.0 \text{ m, whichever is the lesser.}$$

The minimum value of  $w = 1.0 \text{ m}$

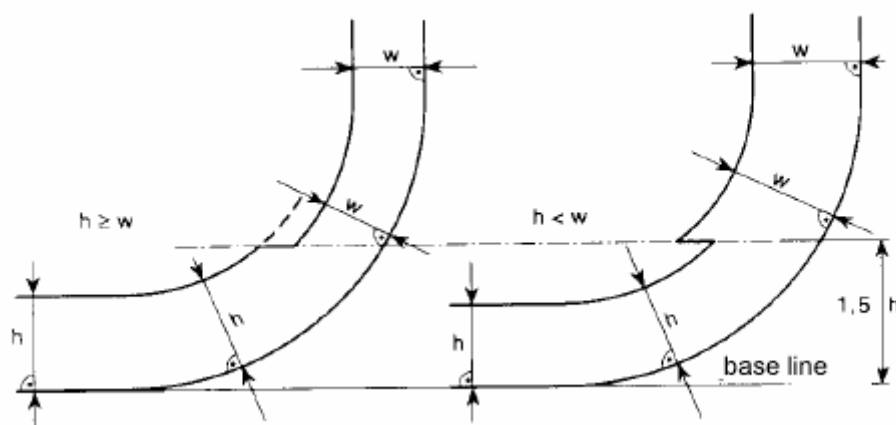

**Figure 2 – Oil fuel tank boundary lines for the purpose of paragraphs 7 and 8**

9 Lines of oil fuel piping located at a distance from the ship's bottom of less than  $h$ , as defined in paragraph 6, or from the ship's side less than  $w$ , as defined in paragraphs 7 and 8 shall be fitted with valves or similar closing devices within or immediately adjacent to the oil fuel tank. These valves shall be capable of being brought into operation from a readily accessible enclosed space the location of which is accessible from the navigation bridge or propulsion machinery control position without traversing exposed freeboard or superstructure decks. The valves shall close in case of remote control system failure (fail in a closed position) and shall be kept closed at sea at any time when the tank contains oil fuel except that they may be opened during oil fuel transfer operations.

10 Suction wells in oil fuel tanks may protrude into the double bottom below the boundary line defined by the distance  $h$  provided that such wells are as small as practicable and the distance between the well bottom and the bottom shell plating is not less than  $0.5 h$ .

11 Alternatively to paragraphs 6 and either 7 or 8, ships shall comply with the accidental oil fuel outflow performance standard specified below:

- .1 The level of protection against oil fuel pollution in the event of collision or grounding shall be assessed on the basis of the mean oil outflow parameter as follows:

$$O_M < 0.0157 - 1.14E-6 \cdot C \quad 600 \text{ m}^3 \leq C < 5,000 \text{ m}^3$$

$$O_M < 0.010 \quad C \geq 5,000 \text{ m}^3$$

Where  $O_M$  = mean oil outflow parameter;  
 $C$  = total oil fuel volume.

- .2 The following general assumption shall apply when calculating the mean oil outflow parameter:
  - .1 the ship shall be assumed loaded to the partial load line draught  $d_p$  without trim or heel;



- .2 all oil fuel tanks shall be assumed loaded to 98% of their volumetric capacity;
- .3 the nominal density of the oil fuel ( $\rho_n$ ) shall generally be taken as 1,000 kg/m<sup>3</sup>. If the density of the oil fuel is specifically restricted to a lesser value, the lesser value may be applied; and
- .4 for the purpose of these outflow calculations, the permeability of each oil fuel tank shall be taken as 0.99, unless proven otherwise.
- .3 The following assumptions shall be used when combining the oil outflow parameters:

- .1 The mean oil outflow shall be calculated independently for side damage and for bottom damage and then combined into a non-dimensional oil outflow parameter  $O_M$ , as follows:

$$O_M = (0.4 O_{MS} + 0.6 O_{MB}) / C$$

where:

$$\begin{aligned} O_{MS} &= \text{mean outflow for side damage, in m}^3 \\ O_{MB} &= \text{mean outflow for bottom damage, in m}^3 \\ C &= \text{total oil fuel volume.} \end{aligned}$$

- .2 For bottom damage, independent calculations for mean outflow shall be done for 0 m and 2.5 m tide conditions, and then combined as follows:

$$O_{MB} = 0.7 O_{MB(0)} + 0.3 O_{MB(2.5)}$$

where:

$$\begin{aligned} O_{MB(0)} &= \text{mean outflow for 0 m tide condition, and} \\ O_{MB(2.5)} &= \text{mean outflow for minus 2.5 m tide condition, in m}^3. \end{aligned}$$

- .4 The mean outflow for side damage  $O_{MS}$  shall be calculated as follows:

$$O_{MS} = \sum_1^n P_{S(i)} O_{S(i)} \quad [\text{m}^3]$$

where:

$$\begin{aligned} i &= \text{represents each oil fuel tank under consideration;} \\ n &= \text{total number of oil fuel tanks;} \\ P_{S(i)} &= \text{the probability of penetrating oil fuel tank } i \text{ from side damage,} \\ &\quad \text{calculated in accordance with paragraph 11.6 of this regulation;} \\ O_{S(i)} &= \text{the outflow, in m}^3, \text{ from side damage to oil fuel tank } i, \text{ which is} \\ &\quad \text{assumed equal to the total volume in oil fuel tank } i \text{ at 98\%} \\ &\quad \text{filling.} \end{aligned}$$

- .5 The mean outflow for bottom damage shall be calculated for each tidal condition as follows:

$$.1 \quad O_{MB(0)} = \sum_1^n P_{B(i)} O_{B(i)} C_{DB(i)} \text{ [m}^3\text{]}$$

where:

- $i$  = represents each oil fuel tank under consideration;
- $n$  = total number of oil fuel tanks;
- $P_{B(i)}$  = the probability of penetrating oil fuel tank  $i$  from bottom damage, calculated in accordance with paragraph 11.7 of this regulation;
- $O_{B(i)}$  = the outflow from oil fuel tank  $i$ , in  $\text{m}^3$ , calculated in accordance with paragraph 11.5.3 of this regulation; and
- $C_{DB(i)}$  = factor to account for oil capture as defined in paragraph 11.5.4.

$$.2 \quad O_{MB(2.5)} = \sum_1^n P_{B(i)} O_{B(i)} C_{DB(i)} \text{ [m}^3\text{]}$$

where:

- $i$ ,  $n$ ,  $P_{B(i)}$  and  $C_{DB(i)}$  = as defined in subparagraph .1 above
- $O_{B(i)}$  = the outflow from oil fuel tank  $i$ , in  $\text{m}^3$ , after tidal change.

.3 The oil outflow  $O_{B(i)}$  for each oil fuel tank shall be calculated based on pressure balance principles, in accordance with the following assumptions:

- .1 The ship shall be assumed stranded with zero trim and heel, with the stranded draught prior to tidal change equal to the partial load line draught  $d_p$ .
- .2 The oil fuel level after damage shall be calculated as follows:

$$h_F = \{(d_p + t_C - Z_l)(\rho_S)\} / \rho_n$$

- where:  $h_F$  = the height of the oil fuel surface above  $Z_l$ , in m;
- $t_C$  = the tidal change, in m. Reductions in tide shall be expressed as negative values;
- $Z_l$  = the height of the lowest point in the oil fuel tank above the baseline, in m;
- $\rho_S$  = density of seawater, to be taken as  $1,025 \text{ kg/m}^3$ ; and,
- $\rho_n$  = nominal density of the oil fuel, as defined in 11.2.3.

.3 The oil outflow  $O_{B(i)}$  for any tank bounding the bottom shell plating shall be taken not less than the following formula, but no more than the tank capacity:

$$O_{B(i)} = H_W \cdot A$$

where:

$$H_W = 1.0 \text{ m, when } Y_B = 0$$

$$H_W = B_B/50 \text{ but not greater than } 0.4 \text{ m, when } Y_B \text{ is greater than } B_B/5 \text{ or } 11.5 \text{ m, whichever is less}$$

“ $H_W$ ” is to be measured upwards from the midship flat bottom line. In the turn of the bilge area and at locations without a clearly defined turn of the bilge,  $H_W$  is to be measured from a line parallel to the midship flat bottom, as shown for distance “ $h$ ” in Figure 1.

For  $Y_B$  values outboard  $B_B/5$  or 11.5 m, whichever is less,  $H_W$  is to be linearly interpolated.

$Y_B$  = the minimum value of  $Y_B$  over the length of the oil fuel tank, where at any given location,  $Y_B$  is the transverse distance between the side shell at waterline  $d_B$  and the tank at or below waterline  $d_B$ .

$A$  = the maximum horizontal projected area of the oil fuel tank up to the level of  $H_W$  from the bottom of the tank.

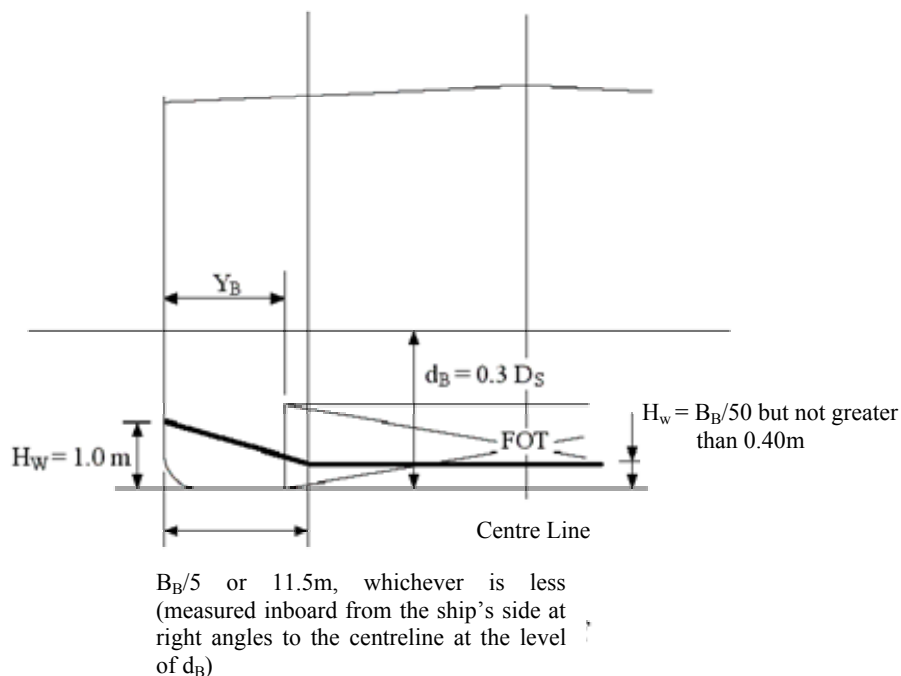

**Figure 3 – Dimensions for calculation of the minimum oil outflow for the purpose of subparagraph 11.5.3.3**

- .4 In the case of bottom damage, a portion from the outflow from an oil fuel tank may be captured by non-oil compartments. This effect is approximated by application of the factor  $C_{DB(i)}$  for each tank, which shall be taken as follows:

$C_{DB(i)} = 0.6$  for oil fuel tanks bounded from below by non-oil compartments;

$C_{DB(i)} = 1$  otherwise.

- .6 The probability  $P_S$  of breaching a compartment from side damage shall be calculated as follows:

.1  $P_S = P_{SL} \cdot P_{SV} \cdot P_{ST}$

where:  $P_{SL} = (1 - P_{Sf} - P_{Sa})$  = probability the damage will extend into the longitudinal zone bounded by  $X_a$  and  $X_f$ ;

$P_{SV} = (1 - P_{Su} - P_{Sl})$  = probability the damage will extend into the vertical zone bounded by  $Z_l$  and  $Z_u$ ;

$P_{ST} = (1 - P_{Sy})$  = probability the damage will extend transversely beyond the boundary defined by  $y$ ;

- .2  $P_{Sa}$ ,  $P_{Sf}$ ,  $P_{Su}$  and  $P_{Sl}$  shall be determined by linear interpolation from the table of probabilities for side damage provided in 11.6.3, and  $P_{Sy}$  shall be calculated from the formulas provided in 11.6.3, where:

$P_{Sa}$  = the probability the damage will lie entirely aft of location  $X_a/L$ ;

$P_{Sf}$  = the probability the damage will lie entirely forward of location  $X_f/L$ ;

$P_{Sl}$  = probability the damage will lie entirely below the tank;

$P_{Su}$  = probability the damage will lie entirely above the tank; and

$P_{Sy}$  = probability the damage will lie entirely outboard the tank.

Compartment boundaries  $X_a$ ,  $X_f$ ,  $Z_l$ ,  $Z_u$  and  $y$  shall be developed as follows:

$X_a$  = the longitudinal distance from aft terminal of  $L$  to the aft most point on the compartment being considered, in m;

$X_f$  = the longitudinal distance from aft terminal of  $L$  to the foremost point on the compartment being considered, in m;

$Z_l$  = the vertical distance from the moulded baseline to the lowest point on the compartment being considered, in m. Where  $Z_l$  is greater than  $D_S$ ,  $Z_l$  shall be taken as  $D_S$ ;

$Z_u$  = the vertical distance from the moulded baseline to the highest point on the compartment being considered, in m. Where  $Z_u$  is greater than  $D_S$ ,  $Z_u$  shall be taken as  $D_S$ ; and,

$y$  = the minimum horizontal distance measured at right angles to the centreline between the compartment under consideration and the side shell, in m<sup>1</sup>.

In way of the turn of the bilge,  $y$  need not to be considered below a distance  $h$  above baseline, where  $h$  is lesser of  $B/10$ , 3 m or the top of the tank.

### .3 Table of Probabilities for side damage

$X_a/L$	$P_{Sa}$	$X_f/L$	$P_{Sf}$	$Z_l/D_S$	$P_{Sl}$	$Z_u/D_S$	$P_{Su}$
0,00	0,000	0,00	0,967	0,00	0,000	0,00	0,968
0,05	0,023	0,05	0,917	0,05	0,000	0,05	0,952
0,10	0,068	0,10	0,867	0,10	0,001	0,10	0,931
0,15	0,117	0,15	0,817	0,15	0,003	0,15	0,905
0,20	0,167	0,20	0,767	0,20	0,007	0,20	0,873
0,25	0,217	0,25	0,717	0,25	0,013	0,25	0,836
0,30	0,267	0,30	0,667	0,30	0,021	0,30	0,789
0,35	0,317	0,35	0,617	0,35	0,034	0,35	0,733
0,40	0,367	0,40	0,567	0,40	0,055	0,40	0,670
0,45	0,417	0,45	0,517	0,45	0,085	0,45	0,599
0,50	0,467	0,50	0,467	0,50	0,123	0,50	0,525
0,55	0,517	0,55	0,417	0,55	0,172	0,55	0,452
0,60	0,567	0,60	0,367	0,60	0,226	0,60	0,383
0,65	0,617	0,65	0,317	0,65	0,285	0,65	0,317
0,70	0,667	0,70	0,267	0,70	0,347	0,70	0,255
0,75	0,717	0,75	0,217	0,75	0,413	0,75	0,197
0,80	0,767	0,80	0,167	0,80	0,482	0,80	0,143
0,85	0,817	0,85	0,117	0,85	0,553	0,85	0,092
0,90	0,867	0,90	0,068	0,90	0,626	0,90	0,046
0,95	0,917	0,95	0,023	0,95	0,700	0,95	0,013
1,00	0,967	1,00	0,000	1,00	0,775	1,00	0,000

$P_{Sy}$  shall be calculated as follows:

$$\begin{aligned}
 P_{Sy} &= (24.96 - 199.6 y/B_S) (y/B_S) && \text{for } y/B_S \leq 0.05 \\
 P_{Sy} &= 0.749 + \{5 - 44.4 (y/B_S - 0.05)\} \{(y/B_S) - 0.05\} && \text{for } 0.05 < y/B_S < 0.1 \\
 P_{Sy} &= 0.888 + 0.56 (y/B_S - 0.1) && \text{for } y/B_S \geq 0.1
 \end{aligned}$$

$P_{Sy}$  is not to be taken greater than 1.

.7 The probability  $P_B$  of breaching a compartment from bottom damage shall be calculated as follows:

<sup>1</sup> For symmetrical tank arrangements, damages are considered for one side of the ship only, in which case all “ $y$ ” dimensions are to be measured from that side. For asymmetrical arrangements reference is made to the Explanatory Notes on matters related to the accidental oil outflow performance, adopted by the Organization by resolution MEPC.122(52).

.1  $P_B = P_{BL} \cdot P_{BT} \cdot P_{BV}$

where:  $P_{BL} = (1 - P_{Bf} - P_{Ba})$  = probability the damage will extend into the longitudinal zone bounded by  $X_a$  and  $X_f$ ;

$P_{BT} = (1 - P_{Bp} - P_{Bs})$  = probability the damage will extend into transverse zone bounded by  $Y_p$  and  $Y_s$ ; and

$P_{BV} = (1 - P_{Bz})$  = probability the damage will extend vertically above the boundary defined by  $z$ ;

.2  $P_{Ba}$ ,  $P_{Bf}$ ,  $P_{Bp}$  and  $P_{Bs}$  shall be determined by linear interpolation from the table of probabilities for bottom damage provided in 11.7.3, and  $P_{Bz}$  shall be calculated from the formulas provided in 11.7.3, where:

$P_{Ba}$  = the probability the damage will lie entirely aft of location  $X_a/L$ ;

$P_{Bf}$  = the probability the damage will lie entirely forward of location  $X_f/L$ ;

$P_{Bp}$  = probability the damage will lie entirely to port of the tank;

$P_{Bs}$  = probability the damage will lie entirely to starboard the tank; and

$P_{Bz}$  = probability the damage will lie entirely below the tank.

Compartment boundaries  $X_a$ ,  $X_f$ ,  $Y_p$ ,  $Y_s$  and  $z$  shall be developed as follows:

$X_a$  and  $X_f$  as defined in 11.6.2;

$Y_p$  = the transverse distance from the port-most point on the compartment located at or below the waterline  $d_B$ , to a vertical plane located  $B_B/2$  to starboard of the ship's centreline;

$Y_s$  = the transverse distance from the starboard-most point on the compartment located at or below the waterline  $d_B$ , to a vertical plane located  $B_B/2$  to starboard of the ship's centreline; and

$z$  = the minimum value of  $z$  over the length of the compartment, where, at any given longitudinal location,  $z$  is the vertical distance from the lower point of the bottom shell at that longitudinal location to the lower point of the compartment at that longitudinal location.

.3 Table of probabilities for bottom damage

$X_a/L$	$P_{Ba}$	$X_f/L$	$P_{Bf}$	$Y_p/B_B$	$P_{Bp}$	$Y_s/B_B$	$P_{Bs}$
0,00	0,000	0,00	0,969	0,00	0,844	0,00	0,000
0,05	0,002	0,05	0,953	0,05	0,794	0,05	0,009
0,10	0,008	0,10	0,936	0,10	0,744	0,10	0,032
0,15	0,017	0,15	0,916	0,15	0,694	0,15	0,063
0,20	0,029	0,20	0,894	0,20	0,644	0,20	0,097
0,25	0,042	0,25	0,870	0,25	0,594	0,25	0,133
0,30	0,058	0,30	0,842	0,30	0,544	0,30	0,171
0,35	0,076	0,35	0,810	0,35	0,494	0,35	0,211
0,40	0,096	0,40	0,775	0,40	0,444	0,40	0,253
0,45	0,119	0,45	0,734	0,45	0,394	0,45	0,297
0,50	0,143	0,50	0,687	0,50	0,344	0,50	0,344
0,55	0,171	0,55	0,630	0,55	0,297	0,55	0,394
0,60	0,203	0,60	0,563	0,60	0,253	0,60	0,444
0,65	0,242	0,65	0,489	0,65	0,211	0,65	0,494
0,70	0,289	0,70	0,413	0,70	0,171	0,70	0,544
0,75	0,344	0,75	0,333	0,75	0,133	0,75	0,594
0,80	0,409	0,80	0,252	0,80	0,097	0,80	0,644
0,85	0,482	0,85	0,170	0,85	0,063	0,85	0,694
0,90	0,565	0,90	0,089	0,90	0,032	0,90	0,744
0,95	0,658	0,95	0,026	0,95	0,009	0,95	0,794
1,00	0,761	1,00	0,000	1,00	0,000	1,00	0,844

$P_{Bz}$  shall be calculated as follows:

$$P_{Bz} = (14.5 - 67 z/D_S) (z/D_S) \quad \text{for } z/D_S \leq 0.1$$

$$P_{Bz} = 0.78 + 1.1 \{(z/D_S - 0.1)\} \quad \text{for } z/D_S > 0.1$$

$P_{Bz}$  is not to be taken greater than 1.

- .8 For the purpose of maintenance and inspection, any oil fuel tanks that do not border the outer shell plating shall be located no closer to the bottom shell plating than the minimum value of  $h$  in paragraph 6 and no closer to the side shell plating than the applicable minimum value of  $w$  in paragraph 7 or 8.

12 In approving the design and construction of ships to be built in accordance with this regulation, Administrations shall have due regard to the general safety aspects, including the need for maintenance and inspection of wing and double bottom tanks or spaces.”

**3 Consequential amendments to the Supplement of the IOPP Certificate (Forms A and B)**

*The following new paragraph 2A is added to the Supplement of the IOPP Certificate (Forms A and B):*

“2A.1 The ship is required to be constructed according to regulation 12A and complies with the requirements of:

paragraphs 6 and either 7 or 8 (double hull construction)

paragraph 11 (accidental oil fuel outflow performance).

2A.2 The ship is not required to comply with the requirements of regulation 12A. ”

#### **4 Amendments to regulation 21**

*The text of existing paragraph 2.2 of regulation 21 on Prevention of oil pollution from oil tankers carrying heavy grade oil as cargo is replaced by the following:*

“oils, other than crude oils, having either a density at 15°C higher than 900 kg/m<sup>3</sup> or a kinematic viscosity at 50°C higher than 180 mm<sup>2</sup>/s; or”

\*\*\*



**ANNEX 3**

**RESOLUTION MEPC.142(54)**

**Adopted on 24 March 2006**

**AMENDMENTS TO THE GUIDELINES FOR THE APPLICATION OF THE REVISED  
MARPOL ANNEX I REQUIREMENTS TO FLOATING PRODUCTION, STORAGE  
AND OFFLOADING FACILITIES (FPSOs) AND FLOATING STORAGE UNITS (FSUs)  
(Resolution MEPC.139(53))**

THE MARINE ENVIRONMENT PROTECTION COMMITTEE,

RECALLING Article 38(a) of the Convention on the International Maritime Organization concerning the functions of the Marine Environment Protection Committee (the Committee) conferred upon it by international conventions for the prevention and control of marine pollution,

NOTING resolution MEPC.139(53) by which the Committee adopted Guidelines for the application of the revised MARPOL Annex I requirements to Floating Production, Storage and Offloading facilities (FPSOs) and Floating Storage Units (FSUs),

HAVING CONSIDERED proposed amendments to the Guidelines concerning the applicability of new regulation 12A of MARPOL Annex I on oil fuel tank protection to FPSOs and FSUs,

1. ADOPTS the Amendments to the Guidelines for the application of the revised MARPOL Annex I requirements to Floating Production, Storage and Offloading facilities (FPSOs) and Floating Storage Units (FSUs), the text of which is set out in the Annex to the present resolution; and
2. INVITES Member Governments to give due consideration to the Guidelines, as amended, when implementing the requirements prescribed in regulation 12A of the revised MARPOL Annex I.

ANNEX

1 The table in annex 1 to the Guidelines for the application of the revised MARPOL Annex I requirements to FPSOs and FSUs is amended as follows:

.1 *Insert an additional row below regulation 12 as follows:*

12A	Oil fuel tank protection	Applies to new purpose built FPSOs and FSUs only excluding the requirements of paragraph 6. However, when undertaking any voyage away from the operating station for whatever purpose, the double bottom oil fuel tanks are to be empty unless they are in compliance with the requirements of paragraph 6.
-----	--------------------------	---

.2 *Amend row relating to regulation 37 to read as follows:*

37.1 – 37.3	SOPEP	Applies in respect of SOPEP. However, contingency plan in accordance with requirements of OPRC Art 3(2) may be accepted under UI 48 as meeting this requirement. In such cases a separate SOPEP in accordance with the MARPOL format is not required. This acceptance of the contingency plan does not apply to a disconnectable FPSO/FSU unless that plan remains applicable when the FPSO/FSU is not connected to the riser.
-------------	-------	--

.3 *Insert an additional row below regulation 37 as follows:*

37.4	Access to stability and residual strength calculation programmes	Applicable
------	--	------------

2 In the record of construction and equipment for FPSOs and FSUs, new section 3A is added as follows:

**“3A. Oil fuel tank protection (regulation 12A)**

3A.1 The ship is required to be constructed according to regulation 12A and complies with the requirements of:

paragraph 7 or 8 (double side construction)

paragraphs 6 and either 7 or 8 (double hull construction)

paragraph 11 (accidental oil fuel outflow performance).

3A.2 The ship is not required to comply with the requirements of regulation 12A. ”

\*\*\*



## ANNEX 4

## RESOLUTION MEPC.143(54)

Adopted on 24 March 2006

**AMENDMENTS TO THE ANNEX OF THE PROTOCOL OF 1978 RELATING  
TO THE INTERNATIONAL CONVENTION FOR THE PREVENTION OF  
POLLUTION FROM SHIPS, 1973****(Addition of regulation 13 to Annex IV of MARPOL 73/78)**

THE MARINE ENVIRONMENT PROTECTION COMMITTEE,

RECALLING Article 38(a) of the Convention on the International Maritime Organization concerning the functions of the Marine Environment Protection Committee (the Committee) conferred upon it by international conventions for the prevention and control of marine pollution,

NOTING article 16 of the International Convention for the Prevention of Pollution from Ships, 1973 (hereinafter referred to as the "1973 Convention") and article VI of the Protocol of 1978 relating to the International Convention for the Prevention of Pollution from Ships, 1973 (hereinafter referred to as the "1978 Protocol") which together specify the amendment procedure of the 1978 Protocol and confer upon the appropriate body of the Organization the function of considering and adopting amendments to the 1973 Convention, as modified by the 1978 Protocol (MARPOL 73/78),

HAVING CONSIDERED the proposed new regulation 13 of Annex IV of MARPOL 73/78 concerning port State control on operational requirements,

1. ADOPTS, in accordance with article 16(2)(b), (c) and (d) of the 1973 Convention, the new regulation 13 of Annex IV of MARPOL 73/78, the text of which is set out at Annex to the present resolution;
2. DETERMINES, in accordance with article 16(2)(f)(iii) of the 1973 Convention, that the revised Annex IV shall be deemed to have been accepted on 1 February 2007, unless, prior to that date, not less than one third of the Parties to MARPOL 73/78 or by the Parties the combined merchant fleets of which constitute not less than 50 per cent of the gross tonnage of the world's merchant fleet, have notified to the Organization their objections to the amendments;
3. INVITES Parties to MARPOL 73/78 to note that, in accordance with article 16(2)(g)(ii) of the 1973 Convention, the said amendments shall enter into force on 1 August 2007 upon their acceptance in accordance with paragraph 2 above;
4. REQUESTS the Secretary-General, in conformity with article 16(2)(e) of the 1973 Convention, to transmit to all Parties to MARPOL 73/78 certified copies of the present resolution and the text of the amendments contained in the Annex; and
5. REQUESTS FURTHER the Secretary-General to transmit copies of this resolution and its Annex to Members of the Organization which are not Parties to MARPOL 73/78.

ANNEX

**AMENDMENTS TO THE REVISED MARPOL ANNEX IV**

*The following new chapter 5 and regulation 13 are added after the existing regulation 12:*

**Chapter 5 – Port State Control**

**“Regulation 13 – Port State control on operational requirements”\***

1. A ship when in a port or an offshore terminal of another Party is subject to inspection by officers duly authorized by such Party concerning operational requirements under this Annex, where there are clear grounds for believing that the master or crew are not familiar with essential shipboard procedures relating to the prevention of pollution by sewage.
2. In the circumstances given in paragraph (1) of this regulation, the Party shall take such steps as will ensure that the ship shall not sail until the situation has been brought to order in accordance with the requirements of this Annex.
3. Procedures relating to the port State control prescribed in article 5 of the present Convention shall apply to this regulation.
4. Nothing in this regulation shall be construed to limit the rights and obligations of a Party carrying out control over operational requirements specifically provided for in the present Convention.”

\*\*\*

---

\* Refer to procedures for port State control adopted by the Organization by resolution A.787(19) and amended by resolution A.882(21); see IMO sales publication IMO-650E.

## ANNEX 5

## RESOLUTION MEPC.144(54)

Adopted on 24 March 2006

**AMENDMENTS TO THE CODE FOR THE CONSTRUCTION AND EQUIPMENT OF SHIPS CARRYING DANGEROUS CHEMICALS IN BULK (BCH CODE)**

THE MARINE ENVIRONMENT PROTECTION COMMITTEE,

RECALLING article 38(a) of the Convention on the International Maritime Organization concerning the functions of the Marine Environment Protection Committee (the Committee) conferred upon it by international conventions for the prevention and control of marine pollution,

RECALLING ALSO resolution MEPC.20(22) by which the Committee adopted the Code for the Construction and Equipment of Ships Carrying Dangerous Chemicals in Bulk (BCH Code),

NOTING article 16 of the International Convention for the Prevention of Pollution from Ships, 1973 (hereinafter referred to as the "1973 Convention") and article VI of the Protocol of 1978 relating to the International Convention for the Prevention of Pollution from Ships, 1973 (hereinafter referred to as the "1978 Protocol") which together specify the amendment procedure of the 1978 Protocol and confer upon the appropriate body of the Organization the function of considering and adopting amendments to the 1973 Convention, as modified by the 1978 Protocol (MARPOL 73/78),

CONSIDERING that it is highly desirable for the provisions of the BCH Code which are mandatory under MARPOL 73/78 and recommendatory from a safety standpoint, to remain identical, when adopted by the Marine Environment Protection Committee and the Maritime Safety Committee,

HAVING CONSIDERED the proposed amendments to the BCH Code,

1. ADOPTS, in accordance with article 16(2)(b), (c) and (d) of the 1973 Convention, the amendments to the BCH Code, the text of which is set out at the annex to the present resolution;
2. DETERMINES, in accordance with article 16(2)(f)(iii) of the 1973 Convention, that the amendments to the BCH Code shall be deemed to have been accepted on 1 February 2007 unless, prior to that date, not less than one-third of the Parties or Parties, the combined merchant fleets of which constitute not less than 50 per cent of the gross tonnage of the world's merchant fleet, have communicated to the Organization their objection to the amendments;
3. INVITES the Parties to note that, in accordance with article 16(2)(g)(ii) of the 1973 Convention, the amendments to the BCH Code shall enter into force on 1 August 2007 upon their acceptance in accordance with paragraph 2 above;
4. INVITES ALSO the Maritime Safety Committee to note this resolution and take action as appropriate;

5. REQUESTS the Secretary-General, in conformity with article 16(2)(e) of the 1973 Convention, to transmit to all Parties to MARPOL 73/78 certified copies of the present resolution and the text of the amendments to the BCH Code contained in the annex; and

6. REQUESTS FURTHER the Secretary-General to transmit copies of the present resolution and its annex to the Members of the Organization which are not Parties to MARPOL 73/78.



## ANNEX

### AMENDMENTS TO THE CODE FOR THE CONSTRUCTION AND EQUIPMENT OF SHIPS CARRYING DANGEROUS CHEMICALS IN BULK (BCH CODE)

The BCH Code is amended as follows:

#### **Preamble**

1 The following new paragraph is added:

“7 The Code has been revised to reflect the 2007 revision of MARPOL Annex II”

#### **CHAPTER I** General

##### **1.1 Purpose**

2 In the second sentence, the words “as defined in regulation 1(1) of Annex II thereof” are deleted and the references to (Pollution Category) “A, B or C” are replaced by “X, Y or Z”.

##### **1.4 Definitions**

3 Paragraph 1.4.16A is replaced by the following:

“1.4.16A *Noxious Liquid Substance* means any substance indicated in the Pollution Category column of chapter 17 or 18 of the International Bulk Chemical Code, or the current MEPC.2/Circular or provisionally assessed under the provisions of regulation 6.3 of the amendments to the Annex of the Protocol of 1978 relative to the International Convention for the Prevention of Pollution from Ships, 1973, as falling into Category X, Y or Z.”

4 In paragraph 1.4.16B the existing text is deleted and the word “Deleted” is inserted.

5 The paragraph number of the definition of “anniversary date” which was adopted as “1.4.16C” by resolution MEPC.41(29) is amended to read “1.4.16D”.

##### **1.7 Effective date**

6 In the second sentence of paragraph 1.7.2, the reference to “regulation 1(12)” is replaced by “regulation 1.17”.

##### **1.8 New products**

7 In the first sentence of paragraph 1.8, the reference to (Pollution Category) “A, B or C” is replaced by “X, Y or Z”.

## **CHAPTER II** Cargo Containment

### G – MATERIALS OF CONSTRUCTION

#### **2.17 General**

8 The existing text is replaced by the following:

“2.17.1 Structural materials used for tank construction, together with associated piping, pumps, valves, vents and their jointing materials, should be suitable at the temperature and pressure for the cargo to be carried in accordance with recognized standards. Steel is assumed to be the normal material of construction.

2.17.2 Where applicable, the following should be taken into account in selecting the material of construction:

- .1 notch ductility at the operating temperature;
- .2 corrosive effect of the cargo; and
- .3 possibility of hazardous reactions between the cargo and the material of construction.

2.17.3 The shipper of the cargo is responsible for providing compatibility information to the ship operator and/or master. This must be done in a timely manner before transportation of the product. The cargo shall be compatible with all materials of construction such that:

- .1 no damage to the integrity of the materials of construction is incurred; and
- .2 no hazardous, or potentially hazardous reaction is created.

2.17.4 When a product is submitted to IMO for evaluation, and where compatibility of the product with materials referred to in paragraph 2.17 renders special requirements, the GESAMP/EHS Product Data Reporting Form shall provide information on the required materials of construction. These requirements shall be reflected in chapter IV and consequentially be referred to in *column o* of chapter 17 of the IBC Code. The reporting form shall also indicate if no special requirements are necessary. The producer of the product is responsible for providing the correct information.”

#### **2.18 Additional requirements**

9 In paragraph 2.18, the existing text is deleted and the word “Deleted” is inserted.

**CHAPTER III**  
Safety equipment and related considerations

E – FIRE PROTECTION

10 After the heading, the following words are inserted:

“(SOLAS regulations referred to in Part E mean, unless expressly provided otherwise, regulations in chapter II-2 of the International Convention for the Safety of Life at Sea, 1974 and its relevant amendments adopted before by resolution MSC.99(73))”.

**3.13 Fire safety arrangements**

11 In paragraph 3.13.3 the existing text is deleted and the word “Deleted” is inserted.

12 The following new paragraph 3.13.5 is added:

“3.13.5 The following requirements in SOLAS chapter II-2, as adopted by MSC.99(73), should apply:

- (a) regulations II-2/4.5.10.1.1 and 4.5.10.1.4 and a system for continuous monitoring of the concentration of flammable vapours shall be fitted on ships of 500 tons gross tonnage and over by the date of the first scheduled dry-docking after [the date of entry into force of the amendment], but not later than [3 years after the date of entry into force of the amendment]. Sampling points or detector heads should be located in suitable positions in order that potentially dangerous leakages are readily detected. When the flammable vapour concentration reaches a pre-set level which shall not be higher than 10% of the lower flammable limit, a continuous audible and visual alarm signal shall be automatically effected in the pump-room and cargo control room to alert personnel to the potential hazard. However, existing monitoring systems already fitted having a pre-set level not greater than 30% of the lower flammable limit may be accepted. Notwithstanding the above provisions, the Administration may exempt ships not engaged on international voyages from those requirements;
- (b) regulations 13.3.4.2 to 13.3.4.5 and 13.4.3 should apply to ships of 500 tons gross tonnage and over;
- (c) regulations in Part E of chapter II-2 of SOLAS Convention except regulations 16.3.2.2 and 16.3.2.3 thereof, should apply to ships, regardless of their sizes;
- (d) where deep-fat cooking equipment is newly installed, regulation 10.6.4 should apply; and
- (e) fire-extinguishing systems using Halon 1211, 1301, and 2402 and perfluorocarbons should not be newly installed as prohibited by regulation 10.4.1.3.”.

## F – PERSONAL PROTECTION

13 After the heading, the following words are inserted:

“(SOLAS regulations referred to in Part F mean, unless expressly provided otherwise, regulations in chapter II-2 of the International Convention for the Safety of Life at Sea, 1974 and its relevant amendments adopted before by resolution MSC.99(73))”.

### **CHAPTER IV** Special requirements

#### **4.12 Materials of construction**

14 In paragraph 4.12, the existing text is deleted and the word “Deleted” is inserted.

#### **4.15 Cargo contamination**

15 In paragraph 4.15.1, the existing text is deleted and the word “Deleted” is inserted.

### **CHAPTER V** Operational requirements

#### **5.2 Cargo information**

16 In paragraph 5.2.5, the viscosity figure “25 mPa”, which appears twice, is replaced with “50 mPa”.

17 In paragraph 5.2.6, the existing text is deleted and the word “Deleted” is inserted.

18 In paragraph 5.2.7, the existing text is deleted and the word “Deleted” is inserted.

### **CHAPTER VA** Additional measures for the protection of the marine environment

19 The existing text is deleted and the word “Deleted” is inserted.

### **CHAPTER VI** Summary of minimum requirements

20 The IBC/BCH cross-references to the requirements under Materials of construction (column *m*) and the following cross-references under special requirements (column *o*) are deleted:

“IBC Code reference	BCH Code reference
15.16.1	4.15.1
16.2.7	5.2.6
16.2.8	5.2.7
16A.2.2	5A.2.2”

### **CHAPTER VIII**

#### Transport of liquid chemical wastes

21 In paragraph 8.3.2.2 reference to “chapter 19” of the IBC Code is replaced by “chapter 20”.

**APPENDIX**

Model form of Certificate of Fitness for the  
Carriage of Dangerous Chemicals in Bulk

22 The existing form is replaced by the following:

**“MODEL FORM OF CERTIFICATE OF FITNESS FOR THE CARRIAGE OF  
DANGEROUS CHEMICALS IN BULK**

**CERTIFICATE OF FITNESS FOR  
THE CARRIAGE OF DANGEROUS CHEMICALS IN BULK**

*(Official seal)*

Issued under the provisions of the

CODE FOR THE CONSTRUCTION AND EQUIPMENT OF SHIPS CARRYING  
DANGEROUS CHEMICALS IN BULK  
(resolutions MSC.9(53) and MEPC.20(22), as amended)

under the authority of the Government of

.....

*(full official designation of country)*

by.....

*(full designation of the competent person or organization recognized by the Administration)*

**Particulars of ship<sup>1</sup>**

Name of ship .....  
Distinctive number or letters .....  
Port of registry .....  
Gross tonnage .....  
Ship Type (Code paragraph 2.2.4) .....  
IMO Number<sup>2</sup> .....

Date on which keel was laid or on which the ship was at a  
similar stage of construction or (in the case of a converted ship)  
date on which conversion to chemical tanker was commenced .....

The ship also complies fully with the following amendments to the Code:

.....  
.....

<sup>1</sup> Alternatively, the particulars of the ship may be placed horizontally in boxes.  
<sup>2</sup> In accordance with IMO ship identification number scheme adopted by the Organization by resolution A.600(15).

The ship is exempted from compliance with the following provisions of the Code:

.....  
.....

THIS IS TO CERTIFY:

- 1 That the ship has been surveyed in accordance with the provisions of section 1.6 of the Code;
- 2 That the survey showed that the construction and equipment of the ship and the condition thereof are in all respects satisfactory and that the ship:
  - .1 complies with the relevant provisions of the Code applicable to ships referred to in 1.7.2;
  - .2 complies with the relevant provisions of the Code applicable to ships referred to in 1.7.3;
- 3 That the ship has been provided with a manual in accordance with Appendix 4 of MARPOL Annex II as called for by regulation 14 of the Annex, and that the arrangements and equipment of the ship prescribed in the Manual are in all respects satisfactory;
- 4 That the ship meets the requirements for the carriage in bulk of the following products, provided that all relevant operational provisions of the Code and MARPOL Annex II are observed:

Product	Conditions of carriage (tank numbers, etc.)	Pollution Category
Continued on attachment 1, additional signed and dated sheets <sup>3</sup> Tank numbers referred to in this list are identified on attachment 2, signed and dated tank plan.		

- 5 That, in accordance with 1.7.3/2.2.5<sup>3</sup>, the provisions of the Code are modified in respect of the ship in the following manner:
 

.....
- 6 That the ship must be loaded:
  - .1 in accordance with the loading conditions provided in the approved loading manual, stamped and dated ..... and signed by a responsible officer of the Administration, or of an organization recognized by the Administration<sup>3</sup>;

<sup>3</sup> Delete as appropriate.

.2 in accordance with the loading limitations appended to this Certificate<sup>3</sup>.

Where it is required to load the ship other than in accordance with the above instruction, then the necessary calculations to justify the proposed loading conditions should be communicated to the certifying Administration who may authorize in writing the adoption of the proposed loading condition<sup>4</sup>.

This Certificate is valid until .....<sup>5</sup>  
subject to surveys in accordance with 1.6 of the Code.

Completion date of the survey on which this certificate is based: .....  
(dd/mm/yyyy)

Issued at .....  
(Place of issue of certificate)

.....  
(Date of issue)

.....  
(Signature of authorized official  
issuing the certificate)

(Seal or stamp of the authority, as appropriate)

Notes on completion of Certificate:

- 1 The Certificate can be issued only to ships entitled to fly the flags of States which are a Party to MARPOL 73/78.
- 2 Ship Type: Any entry under this column must relate to all relevant recommendations, e.g., an entry "Type 2" should mean Type 2 in all respects prescribed by the Code. This column would not usually apply in the cases of an existing ship and in such a case should be noted "see paragraph 2.2".
- 3 Products: Products listed in chapter 17 of the Code, or which have been evaluated by the Administration in accordance with 1.8 of the Code, should be listed. In respect of the latter "new" products, any special requirements provisionally prescribed should be noted.
- 4 Products: The list of products the ship is suitable to carry should include the noxious liquid substances of Category Z which are not covered by the Code and should be identified as "chapter 18 Category Z".
- 5 *deleted*

---

<sup>3</sup> Delete as appropriate.

<sup>4</sup> Instead of being incorporated in the Certificate, this text may be appended to the Certificate if signed and stamped.

<sup>5</sup> Insert the date of expiry as specified by the Administration in accordance with 1.6.6.1 of the Code. The day and the month of this day correspond to the anniversary date as defined in 1.4.16D of the Code, unless amended in accordance with 1.6.6.8 of the Code.



- 6 Conditions of carriage: If a Certificate is issued to a ship which is modified in accordance with the provision of regulation 1(12) of MARPOL Annex II the Certificate should indicate in the top of the table of products and conditions of carriage the following statement: “This ship is certificated to carry only pollution hazard chemicals”.

**ENDORSEMENT FOR ANNUAL AND INTERMEDIATE SURVEYS**

THIS IS TO CERTIFY that at a survey required by 1.6.2 of the Code the ship was found to comply with the relevant provisions of the Code.

Annual survey: Signed .....  
(Signature of duly authorized official)  
Place .....  
Date (dd/mm/yyyy) .....

*(Seal or stamp of the Authority, as appropriate)*

Annual/Intermediate<sup>3</sup> survey: Signed .....  
(Signature of duly authorized official)  
Place .....  
Date (dd/mm/yyyy) .....

*(Seal or stamp of the Authority, as appropriate)*

Annual/Intermediate<sup>3</sup> survey: Signed .....  
(Signature of duly authorized official)  
Place .....  
Date (dd/mm/yyyy) .....

*(Seal or stamp of the Authority, as appropriate)*

Annual survey: Signed .....  
(Signature of duly authorized official)  
Place .....  
Date (dd/mm/yyyy) .....

*(Seal or stamp of the Authority, as appropriate)*

---

<sup>3</sup> Delete as appropriate.

**ANNUAL/INTERMEDIATE SURVEY IN ACCORDANCE WITH PARAGRAPH 1.6.6.8.3**

THIS IS TO CERTIFY that, at an annual/intermediate<sup>3</sup> survey in accordance with paragraph 1.6.6.8.3 of the Code, the ship was found to comply with the relevant provisions of the Convention:

Signed .....  
(Signature of duly authorized official)

Place .....

Date (dd/mm/yyyy) .....

*(Seal or stamp of the Authority, as appropriate)*

**ENDORSEMENT TO EXTEND THE CERTIFICATE IF VALID  
FOR LESS THAN 5 YEARS WHERE PARAGRAPH 1.6.6.3 APPLIES**

The ship complies with the relevant provisions of the Convention, and this Certificate shall, in accordance with paragraph 1.6.6.3 of the Code, be accepted as valid until .....

Signed .....  
(Signature of duly authorized official)

Place .....

Date (dd/mm/yyyy) .....

*(Seal or stamp of the Authority, as appropriate)*

**ENDORSEMENT WHERE THE RENEWAL SURVEY HAS BEEN  
COMPLETED AND PARAGRAPH 1.6.6.4 APPLIES**

The ship complies with the relevant provisions of the Convention, and this Certificate shall, in accordance with paragraph 1.6.6.4 of the Code, be accepted as valid until .....

Annual survey:

Signed .....  
(Signature of duly authorized official)

Place .....

Date (dd/mm/yyyy) .....

*(Seal or stamp of the Authority, as appropriate)*

---

<sup>3</sup> Delete as appropriate.

**ENDORSEMENT TO EXTEND THE VALIDITY OF THE CERTIFICATE  
UNTIL REACHING THE PORT OF SURVEY OR FOR A PERIOD  
OF GRACE WHERE PARAGRAPH 1.6.6.5 OR 1.6.6.6 APPLIES**

This Certificate shall, in accordance with paragraph 1.6.6.5/1.6.6.6<sup>3</sup> of the Code, be accepted as valid until .....

Signed .....  
(Signature of duly authorized official)

Place .....

Date (dd/mm/yyyy) .....

*(Seal or stamp of the Authority, as appropriate)*

**ENDORSEMENT FOR ADVANCEMENT OF ANNIVERSARY DATE WHERE  
PARAGRAPH 1.6.6.8 APPLIES**

In accordance with paragraph 1.6.6.8 of the Code, the new anniversary date is .....

Signed .....  
(Signature of duly authorized official)

Place .....

Date (dd/mm/yyyy) .....

*(Seal or stamp of the Authority, as appropriate)*

In accordance with paragraph 1.6.6.8, the new anniversary date is .....

Signed .....  
(Signature of duly authorized official)

Place .....

Date (dd/mm/yyyy) .....

*(Seal or stamp of the Authority, as appropriate)*

---

<sup>3</sup> Delete as appropriate.

**ATTACHMENT 1**  
**TO THE**  
**CERTIFICATE OF FITNESS FOR THE CARRIAGE OF DANGEROUS**  
**CHEMICALS IN BULK**

Continued list of products to those specified in section 3, and their conditions of carriage.

Products	Conditions of carriage (tank numbers, etc.)	Pollution Category

Date  
(*as for Certificate*)

-----  
(*Signature of official issuing the Certificate  
and/or seal of issuing authority*)

**ATTACHMENT 2  
TO THE  
CERTIFICATE OF FITNESS FOR THE CARRIAGE OF DANGEROUS  
CHEMICALS IN BULK**

TANK PLAN (specimen)

Name of ship: .....

Distinctive number or letters: .....

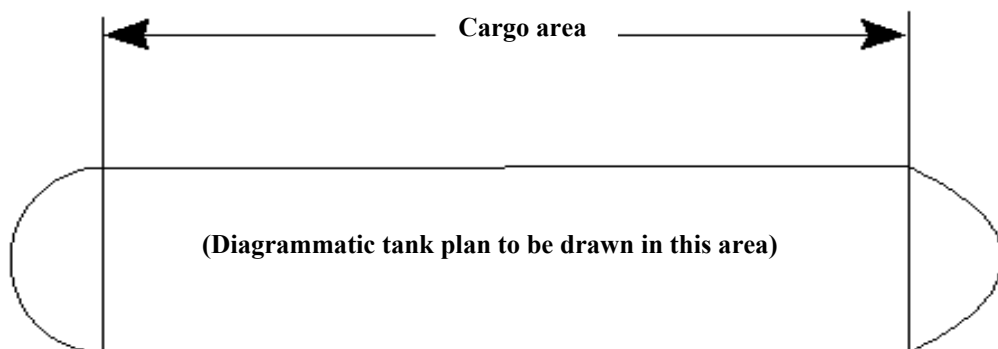

Date .....  
(as for Certificate)

.....  
(Signature of official issuing the Certificate  
and/or seal of issuing authority)"

\*\*\*

## ANNEX 6

## RESOLUTION MEPC.145(54)

Adopted on 24 March 2006

**EARLY AND EFFECTIVE APPLICATION OF THE 2006 AMENDMENTS  
TO THE CODE FOR THE CONSTRUCTION AND EQUIPMENT OF SHIPS  
CARRYING DANGEROUS CHEMICALS IN BULK (BCH CODE)**

THE MARINE ENVIRONMENT PROTECTION COMMITTEE,

RECALLING Article 38(a) of the Convention of the International Maritime Organization concerning the functions of the Marine Environment Protection Committee (the Committee) conferred upon it by international conventions for the prevention and control of marine pollution,

RECALLING ALSO resolution MEPC.20(22) by which the Committee adopted the Code for the Construction and Equipment of Ships Carrying Dangerous Chemicals in Bulk (BCH Code),

HAVING ADOPTED, by resolution MEPC.144(54), the 2006 amendments to the BCH Code,

NOTING that article 16(2)(f)(iii) of the International Convention for the Prevention of Pollution from Ships, 1973 (the 1973 Convention) provides that the aforesaid amendments to the BCH Code shall be deemed to have been accepted on 1 February 2007, unless, prior to that date, not less than one third of the Parties to MARPOL 73/78 or Parties the combined merchant fleets of which constitute not less than 50 per cent of the gross tonnage of the world's merchant fleet, have communicated to the Organization their objections to the amendments,

NOTING ALSO that in accordance with article 16(2)(g)(ii) of the 1973 Convention, the aforesaid amendments to the BCH Code, shall enter into force on 1 August 2007 upon their deemed acceptance in accordance with article 16(2)(f)(iii) of the 1973 Convention,

NOTING IN PARTICULAR that the purpose of the BCH Code is to recommend suitable design criteria, construction standards and other safety measures for ships transporting dangerous and noxious chemical substances in bulk to minimize the risk to the ship, its crew and the environment,

1. INVITES Parties to MARPOL 73/78 to consider the application of the aforesaid amendments to the BCH Code, as soon as practically possible to ships entitled to fly their flag, taking into account that the revised Annex II of MARPOL 73/78 and the amended International Code for the Construction and Equipment of Ships carrying Dangerous Chemicals in Bulk (IBC Code) are expected to enter into force on 1 January 2007;
2. INVITES ALSO the maritime industry to implement the aforesaid amendments to the BCH Code, as soon as possible taking note of the expected entry into force date of the instruments referred to in paragraph 1 above; and
3. INVITES FURTHER the Maritime Safety Committee to note this resolution and take action as appropriate.

\*\*\*





## ANNEX 7

**UNIFIED INTERPRETATION TO REGULATION 12A OF  
THE REVISED MARPOL ANNEX I**

In applying regulation 12A of the revised MARPOL Annex I to Column Stabilized Units (MODUs) as defined in the MODU Code, for the purpose of placing the oil fuel tanks, the location limitations of paragraphs 7 and 8 of the regulation apply to those areas subject to damage as follows:

- .1 only those columns, underwater hulls and braces on the periphery of the unit shall be assumed to be damaged and the damage shall be assumed in the exposed portions of the columns, underwater hulls and braces;
- .2 columns and braces shall be assumed to be damaged at any level between 5.0 m above and 3.0 m below the range of draughts in the MODUs operating manual for normal and severe weather operations; and
- .3 underwater hull and footings shall be assumed to be damaged when operating in a transit condition in the same manner as indicated in .1 and .2, having regard to their shape.

\*\*\*



**ANNEX 8**

**UNIFIED INTERPRETATION TO REGULATION 22.5 OF THE  
REVISED MARPOL ANNEX I**

The term “*pump-room*” means a cargo pump-room. Ballast piping is permitted to be located within the pump-room double bottom provided any damage to that piping does not render the ship’s pumps located in the “*pump-room*” ineffective.

The double bottom protecting the “*pump-room*” can be a void tank, a ballast tank or, unless prohibited by other regulations, a fuel oil tank.

\*\*\*



**ANNEX 9**

**RESOLUTION MEPC.146(54)**

**Adopted on 24 March 2006**

**AMENDMENTS TO THE EXPLANATORY NOTES ON MATTERS RELATED TO  
THE ACCIDENTAL OIL OUTFLOW PERFORMANCE UNDER REGULATION 23  
OF THE REVISED MARPOL ANNEX I**

THE MARINE ENVIRONMENT PROTECTION COMMITTEE,

RECALLING Article 38(a) of the Convention on the International Maritime Organization concerning the functions of the Marine Environment Protection Committee (the Committee) conferred upon it by international conventions for the prevention and control of marine pollution,

NOTING resolution MEPC.122(52) by which the Committee adopted the Explanatory notes on matters related to the accidental oil outflow performance under regulation 23 of the revised MARPOL Annex I,

HAVING CONSIDERED proposed amendments to the Explanatory notes,

1. ADOPTS the Amendments to the Explanatory notes on matters related to the accidental oil outflow performance under regulation 23 of the revised MARPOL Annex I, the text of which is set out in the Annex to the present resolution;
2. INVITES Member Governments to give due consideration to the Explanatory notes, as amended, when implementing the requirements prescribed in regulation 23 of the revised MARPOL Annex I;
3. AGREES to keep the Explanatory notes, as amended, under review in the light of experience gained;
4. INVITES the Maritime Safety Committee to note the Explanatory notes, as amended; and
5. URGES Member Governments to bring the aforementioned Explanatory notes, as amended, to the attention of shipbuilders, shipowners, ship operators and other parties concerned with the design, construction and operation of oil tankers.

ANNEX

AMENDMENTS TO THE EXPLANATORY NOTES ON MATTERS RELATED TO THE  
ACCIDENTAL OIL OUTFLOW PERFORMANCE UNDER REGULATION 23 OF THE  
REVISED MARPOL ANNEX I

*Paragraph 6.3 of Part B – “Guidance on individual regulations” is deleted*

\*\*\*

**ANNEX 10****PROPOSED AMENDMENTS TO THE REVISED ANNEX I OF MARPOL 73/78****(Southern South African Sea Area as a Special Area)**

A new subparagraph .10 is added to regulation 1.11 as follows:

“.10 *the Southern South African Sea Area* means the sea area enclosed by the following co-ordinates:

31° 14' S; 017° 50' E

31° 30' S; 017° 12' E

32° 00' S; 017° 06' E

32° 32' S; 016° 52' E

34° 06' S; 017° 24' E

36° 58' S; 020° 54' E

36° 00' S; 022° 30' E

35° 14' S; 022° 54' E

34° 30' S; 026° 00' E

33° 48' S; 027° 25' E

33° 27' S; 027° 12' E”

\*\*\*





**ANNEX 11****UNIFORM FORMAT OF THE MEPC RESOLUTION FOR THE DESIGNATION  
OF PARTICULARLY SENSITIVE SEA AREAS****RESOLUTION MEPC.xxx(xx)  
Adopted on [DD/MM/YYYY]****DESIGNATION OF [name of sea area]  
AS A PARTICULARLY SENSITIVE SEA AREA**

THE MARINE ENVIRONMENT PROTECTION COMMITTEE,

BEING AWARE of the [ecological], [socio-economic], [and scientific] attributes<sup>1</sup> of [name of sea area] as well as its vulnerability to damage by international shipping activities and the steps taken by [name of proposing Member Government] to address that vulnerability,

NOTING the Revised Guidelines for the Identification and Designation of Particularly Sensitive Sea Areas adopted under resolution A.982(24) (PSSA Guidelines) and the Revised Guidance Document for Submission of PSSA Proposals to IMO set forth in circular MEPC/Circ.510,

HAVING CONSIDERED the proposal from [name of proposing Member Government] to designate [name of sea area] as a Particularly Sensitive Sea Area,

HAVING AGREED that the provisions for the identification and designation of a Particularly Sensitive Area provided in resolution A.982(24) are fulfilled for the [name of sea area],

1. DESIGNATES [name of sea area] as defined in Annex 1<sup>2</sup> to this resolution as a Particularly Sensitive Sea Area;
2. INVITES Member Governments to recognize the [ecological], [socio-economic], [and scientific] attributes of the area set forth in Annex 2<sup>3</sup> and its vulnerability to damage by international shipping activities set forth in Annex 3<sup>4</sup>; and

---

<sup>1</sup> Since under paragraph 4.4 of the PSSA Guidelines one or more of the ecological, socio-economic, or scientific criteria needs to be fulfilled, these categories are in brackets. The appropriate terminology should be used for each PSSA. This issue is also presented in the second operative paragraph.

<sup>2</sup> Annex 1 should contain the co-ordinates of the PSSA as well as a chartlet on which the PSSA and associated protective measures are marked.

<sup>3</sup> Annex 2 should contain the information submitted to address section 4 of the PSSA Guidelines.

<sup>4</sup> Annex 3 should be a summary that identifies the vulnerability to damage by international shipping activities.

3. FURTHER INVITES Member Governments to note the associated protective measure(s) established to address this vulnerability set forth in Annex 4<sup>5</sup>, and inform ships flying their flag that they should act in accordance with such measure(s).

\*\*\*

---

<sup>5</sup> Annex 4 should contain the APM(s) that have been adopted by the appropriate IMO body. It should also contain a notation to the related documents pertinent to the APM(s).

## ANNEX 12

### GUIDANCE DOCUMENT FOR SUBMISSION OF PSSA PROPOSALS TO IMO

#### 1 BACKGROUND

1.1 In December 2005, the International Maritime Organization (IMO) Assembly adopted resolution A.982(24) which sets forth the detailed requirements to be included in an application for designation of a Particularly Sensitive Sea Area (PSSA). This resolution supersedes Annex 2 of Assembly resolution A.927(22). Its requirements should be followed in preparing a PSSA proposal. To assist Member Governments in meeting the requirements of resolution A.982(24), this document provides guidance for the development, drafting, and submission of proposals to IMO for the designation of a PSSA. This document sets forth the issues that should be included in such a proposal to facilitate its assessment and approval by IMO's Marine Environment Protection Committee (MEPC); however, the assessment and determination of whether a PSSA should be designated are ultimately controlled by whether the proposal meets the provisions of resolution A.982(24).

1.2 A PSSA is a comprehensive management tool at the international level that provides a mechanism for reviewing an area that is vulnerable to damage by international shipping and determining the most appropriate way to address that vulnerability. In general, to be identified as a PSSA, three elements must be present: (1) the area must have certain attributes (ecological, socio-economic, or scientific); (2) it must be vulnerable to damage by international shipping activities; and (3) there must be a measure<sup>1</sup> with an identified legal basis that can be adopted by IMO to prevent, reduce, or eliminate risks from these activities. If approved by IMO, the end result will be an area designated as a "Particularly Sensitive Sea Area" and one or more IMO-adopted measures for ships to follow. Information on each of the PSSAs that has been designated by IMO is available at [www.imo.org](http://www.imo.org).

1.3 Proposals must be submitted in accordance with the IMO rules and procedures for the submission of documents. Governments<sup>2</sup> may check with the IMO Secretariat for the precise submission deadline as well as other administrative rules.

#### 2 INITIAL CONSIDERATIONS

2.1 Before proceeding to IMO, a determination must be made that there is a threat to the attributes of an area from international shipping. If the threat is primarily being caused by shipping registered domestically, it may be more appropriate to address such a threat as a matter of domestic law. After the threat is identified, a decision can be made as to the most appropriate

---

<sup>1</sup> The reference to "measure" or "Associated Protective Measure" is used both in the singular and plural throughout this Guidance Document. It is important to recognize that an identified vulnerability may be addressed by only one or by more than one measure or Associated Protective Measure and that therefore the use of this terminology in the singular or plural should not be taken as any indication to the contrary.

<sup>2</sup> The word "Government" is used both in the singular and plural throughout the text of this Guidance Document. It is clear, however, that the PSSA Guidelines recognize that an application for designation of a PSSA may be submitted by one or more Governments and therefore the use of this terminology in the singular or plural should not be taken as an indication to the contrary.

means to address it. Threats to the marine environment from international shipping can generally be separated into three categories: (1) impacts from accidents (e.g., groundings, spills, collisions); (2) operational discharges (i.e., oil, noxious liquid substances, sewage, garbage, air emissions, introduction of harmful aquatic organisms and pathogens through ships' ballast water); and (3) physical damage to marine habitats or organisms (i.e., anchor damage, ship strikes of marine animals, smothering of species/habitats, harmful effects from anti-fouling systems). Damage may also be caused from intentional violations of existing rules and regulations.

2.2 A proposal for PSSA designation may only be submitted by an IMO Member Government. To successfully develop a PSSA proposal, it may be necessary to assemble a small team of national experts in the country concerned. The team should include members who can describe and document the attributes of the area as well as the damage that has been or could be caused to the area. It should also include members who are familiar with the vessel operations in the area and the IMO measures that can be proposed to address the damage. The proposing Member Government's representative(s) to IMO should also participate to facilitate submission and presentation of the proposal.

### **3 REQUIRED ELEMENTS FOR A PSSA APPLICATION**

#### **3.1 Summary of the Proposal**

3.1.1 The application should first clearly set forth a summary of the objectives of the proposed PSSA designation, the location of the area, the need for protection, the proposed associated protective measure, and demonstrate how the identified vulnerability will be addressed by the existing or proposed associated protective measure (APM). The summary should also include the reasons why the proposed associated protective measure is the preferred method for providing protection for the area to be identified as a PSSA.

#### **3.2 Description of the Area**

3.2.1 The application must contain the location of the proposed area, including the geographic co-ordinates and a chart on which the area is marked. A buffer zone, which is an area contiguous to the site-specific or core feature of the proposed PSSA, may be included within the boundaries of the PSSA; however, the need for such a zone should be justified as to how it contributes to the protection of the core area.

#### **3.3 Significance of the Area: Ecological, Socio-Economic, or Scientific Criteria**

3.3.1 An area being proposed for PSSA identification must satisfy one or more of the economic, socio-economic, or scientific criteria and information and supporting documentation should be provided to support that at least one criterion exists throughout the proposed area, although the same criterion need not be present throughout the entire area.

3.3.2 Proposing Member Governments should review the section of the PSSA Guidelines for a complete description of each criterion; however, the titles of the criteria are as follows:

- .1 ***Ecological criteria***
  - .1 *Uniqueness or rarity*
  - .2 *Critical habitat*
  - .3 *Dependency*
  - .4 *Representativeness*
  - .5 *Diversity*
  - .6 *Productivity*
  - .7 *Spawning or breeding grounds*
  - .8 *Naturalness*
  - .9 *Integrity*
  - .10 *Fragility*
  - .11 *Bio-geographic importance*
- .2 ***Social, cultural and economic criteria***
  - .1 *Social or economic dependency*
  - .2 *Human dependency*
  - .3 *Cultural heritage*
- .3 ***Scientific and educational criteria***
  - .1 *Research*
  - .2 *Baseline for monitoring studies*
  - .3 *Education*

### **3.4 Vulnerability to Impacts by International Shipping Activities**

3.4.1 In addition to meeting at least one of the criteria listed above, the recognized attributes of the area should be at risk from international shipping activities. Proposing Member Governments should review section 5 of the PSSA Guidelines for a complete description of such factors:

- .1 ***Vessel Traffic Characteristics***
  - .1 *Operational factors*
  - .2 *Vessel types*
  - .3 *Traffic characteristics*
  - .4 *Harmful substances carried*
- .2 ***Natural Factors***
  - .1 *Hydrographical*
  - .2 *Meteorological*
  - .3 *Oceanographic*
- .3 Other helpful information as suggested in paragraph 5.2 of the PSSA Guidelines.

### 3.5 Associated Protective Measures

3.5.1 The application should propose the APMs available through IMO and show how they provide the needed protection from the threats of damage posed by the international shipping activities occurring in and around the area. If the application identifies a new APM, then the proposing Member Government must append a draft of the proposal which is intended to be submitted to the appropriate Sub-Committee or Committee to its application. If the measure is not already available under an IMO instrument, the proposal should set forth its legal basis and/or the steps that the proposing Member Government has taken or will take to have the measure approved and adopted by IMO pursuant to an identified legal basis. If a protective measure already exists to protect the area, then the application should show how the area is being protected by this measure. Additional APMs may be introduced in the future to address identified vulnerabilities and, as with APMs that are proposed at the time of the initial application for PSSA designation, such measures must comply with the Guidelines.

- .1 *Types of Measures* – The possible measures may include ships’ routing or reporting measures; discharge restrictions; operational criteria; and prohibited activities, and should be specifically tailored to meet the need of the area at risk.
- .2 *Legal Basis* – Each APM must have an identified legal basis and the application should set forth the information on the consistency of the APM with the legal instrument under which the APM is proposed. (Guidelines, paragraphs 7.5.2.3 and 7.6.) The legal basis for APMs are: (i) any measure that is already available under an existing IMO instrument; or (ii) any measure that does not yet exist but could become available through the amendment of an IMO instrument or adoption of a new IMO instrument. The legal basis for any such measure would only be available after the IMO instrument was amended or adopted, as appropriate; or (iii) any measures proposed for adoption in the territorial sea<sup>3</sup> or pursuant to Article 211(6) of the United Nations Convention on the Law of the Sea where existing measures or a generally applicable measure (as set forth in (ii)) would not adequately address the particularized need of the proposed area. If the country is proceeding under a measure that is not yet available under an IMO instrument, the application should contain the steps that the Government is pursuing to have the measure approved or adopted by IMO pursuant to an identified legal basis.
- .3 *Categories of Ships* – The application should clearly specify the category or categories of ships to which the proposed associated protective measures would apply, consistent with the provisions of the United Nations Convention on the Law of the Sea – including those related to vessels entitled to sovereign immunity – and other pertinent instruments.
- .4 *Impact on Navigation* – The application should indicate the possible impact of any proposed measures on the safety and efficiency of navigation, taking into account the area of the ocean in which the proposed measures are to be implemented. The application should set forth such information as implications for ship safety and the impact on ship operations.

---

<sup>3</sup> This provision does not derogate from the rights and duties of coastal States in the territorial sea as provided for in the United Nations Convention on the Law of the Sea.

### 3.6 Miscellaneous Issues

3.6.1 *Area* – The application should include a nautical chartlet on which the location of the area and the existing or proposed associated protective measure are clearly marked. The size of the area should be commensurate with that necessary to address the identified need.

3.6.2 *Summary of Measures* – The application should contain a summary of steps taken, if any, to protect the proposed area. This would include any domestic regulations, any previously adopted IMO measures, and measures taken to address the adverse effects from activities other than shipping. It would also be useful to include whether the area has received any international designation, such as listed on the World Heritage List or declared a Biosphere Reserve.

3.6.3 *Enforcement* – The details of action to be taken pursuant to domestic law for the failure of a ship to comply with the requirements of the associated protective measures should also be provided as well as a statement that such action shall be consistent with international law as reflected in the United Nations Convention on the Law of the Sea.

3.6.4 *Joint Proposals* – Where two or more Governments have a common interest in a particular area, they should formulate a co-ordinated proposal. The proposal should contain integrated measures and procedures for co-operation between the jurisdictions of the proposing Governments.

3.6.5 *Implementation after Designation* – Proposing Governments should ensure that any associated protective measure is implemented in accordance with international law as reflected in the United Nations Convention on the Law of the Sea. Information regarding such measures should be broadly disseminated to mariners operating in the designated area. All associated protective measures should be identified on charts in accordance with the symbols and methods of the International Hydrographic Office (IHO). A designated PSSA may also be charted with appropriate symbology.

3.6.6 *Technical Assistance* – If, in preparing its PSSA application, a Member Government requires technical assistance, that Government is encouraged to request such assistance from IMO.

\*\*\*





**ANNEX 13****PROPOSED AMENDMENTS TO ANNEX III OF MARPOL 73/78****(Revised Annex III)**

The existing text of MARPOL Annex III is replaced by the following:

**“REGULATIONS FOR THE PREVENTION OF POLLUTION BY HARMFUL SUBSTANCES CARRIED BY SEA IN PACKAGED FORM****Regulation 1***Application*

- (1) Unless expressly provided otherwise, the regulations of this Annex apply to all ships carrying harmful substances in packaged form.
  - (1.1) For the purpose of this Annex, “harmful substances” are those substances which are identified as marine pollutants in the International Maritime Dangerous Goods Code (IMDG Code)\* or which meet the criteria in the Appendix of this Annex.
  - (1.2) For the purposes of this Annex, “packaged form” is defined as the forms of containment specified for harmful substances in the IMDG Code.
- (2) The carriage of harmful substances is prohibited, except in accordance with the provisions of this Annex.**
- (3) To supplement the provisions of this Annex, the Government of each Party to the Convention shall issue, or cause to be issued, detailed requirements on packing, marking, labelling, documentation, stowage, quantity limitations and exceptions for preventing or minimizing pollution of the marine environment by harmful substances.\*
- (4) For the purposes of this Annex, empty packagings which have been used previously for the carriage of harmful substances shall themselves be treated as harmful substances unless adequate precautions have been taken to ensure that they contain no residue that is harmful to the marine environment.
- (5) The requirements of this Annex do not apply to ship’s stores and equipment.

---

\* Refer to the IMDG Code adopted by the Organization by resolution MSC.122(75), as it has been or may be amended by the Maritime Safety Committee; see IMO sales publications IMO-200E and IMO-210E.

## **Regulation 2**

### *Packing*

Packages shall be adequate to minimize the hazard to the marine environment, having regard to their specific contents.

## **Regulation 3**

### *Marking and labelling*

- (1) Packages containing a harmful substance shall be durably marked with the correct technical name (trade names alone shall not be used) and, further, shall be durably marked or labelled to indicate that the substance is a marine pollutant. Such identification shall be supplemented where possible by any other means, for example, by use of the relevant United Nations number.
- (2) The method of marking the correct technical name and of affixing labels on packages containing a harmful substance shall be such that this information will still be identifiable on packages surviving at least three months' immersion in the sea. In considering suitable marking and labelling, account shall be taken of the durability of the materials used and of the surface of the package.
- (3) Packages containing small quantities of harmful substances may be exempted from the marking requirements.\*

## **Regulation 4<sup>§</sup>**

- (1) In all documents relating to the carriage of harmful substances by sea where such substances are named, the correct technical name of each such substance shall be used (trade names alone shall not be used) and the substance further identified by the addition of the words "MARINE POLLUTANT".
- (2) The shipping documents supplied by the shipper shall include, or be accompanied by, a signed certificate or declaration that the shipment offered for carriage is properly packaged and marked, labelled or placarded as appropriate and in proper condition for carriage to minimize the hazard to the marine environment.
- (3) Each ship carrying harmful substances shall have a special list or manifest setting forth the harmful substances on board and the location thereof. A detailed stowage plan which sets out the location of the harmful substances on board may be used in place of such special list or manifest. Copies of such documents shall also be retained on shore by the owner of the ship or his representative until the harmful substances are unloaded. A copy of one of these documents shall be made

---

\* Refer to the specific exemptions provided for in the IMDG Code; see IMO sales publications IMO-200E and IMO-210E.

§ Reference to "documents" in this regulation does not preclude the use of electronic data processing (EDP) and electronic data interchange (EDI) transmission techniques as an aid to paper documentation.

available before departure to the person or organization designated by the port State authority.

- (4) At any stopover, where any loading or unloading operations, even partial, are carried out, a revision of the documents listing the harmful substances taken on board, indicating their location on board or showing a detailed stowage plan, shall be made available before departure to the person or organization designated by the port State authority.
- (5) When the ship carries a special list or manifest or a detailed stowage plan, required for the carriage of dangerous goods by the International Convention for the Safety of Life at Sea, 1974, as amended, the documents required by this regulation may be combined with those for dangerous goods. Where documents are combined, a clear distinction shall be made between dangerous goods and harmful substances covered by this Annex.

### **Regulation 5**

#### *Stowage*

Harmful substances shall be properly stowed and secured so as to minimize the hazards to the marine environment without impairing the safety of the ship and persons on board.

### **Regulation 6**

#### *Quantity limitations*

Certain harmful substances may, for sound scientific and technical reasons, need to be prohibited for carriage or be limited as to the quantity which may be carried aboard any one ship. In limiting the quantity, due consideration shall be given to size, construction and equipment of the ship, as well as the packaging and the inherent nature of the substances.

### **Regulation 7**

#### *Exceptions*

- (1) Jettisoning of harmful substances carried in packaged form shall be prohibited, except where necessary for the purpose of securing the safety of the ship or saving life at sea.
- (2) Subject to the provisions of the present Convention, appropriate measures based on the physical, chemical and biological properties of harmful substances shall be taken to regulate the washing of leakages overboard, provided that compliance with such measures would not impair the safety of the ship and persons on board.

## **Regulation 8**

### *Port State control on operational requirements\**

- (1) A ship when in a port of another Party is subject to inspection by officers duly authorized by such Party concerning operational requirements under this Annex, where there are clear grounds for believing that the master or crew are not familiar with essential shipboard procedures relating to the prevention of pollution by harmful substances.
- (2) In the circumstances given in paragraph (1) of this regulation, the Party shall take such steps as will ensure that the ship shall not sail until the situation has been brought to order in accordance with the requirements of this Annex.
- (3) Procedures relating to the port State control prescribed in article 5 of the present Convention shall apply to this regulation.
- (4) Nothing in this regulation shall be construed to limit the rights and obligations of a Party carrying out control over operational requirements specifically provided for in the present Convention.

## **Appendix to Annex III**

### ***Criteria for the identification of harmful substances in packaged form***

For the purposes of this Annex, substances identified by any one of the following criteria are harmful substances\*:

#### **Category: Acute 1**

96 hr LC <sub>50</sub> (for fish)	≤ 1 mg/l and/or
48 hr EC <sub>50</sub> (for crustacea)	≤ 1 mg/l and/or
72 or 96 hr ErC <sub>50</sub> (for algae or other aquatic plants)	≤ 1 mg/l

---

\* Refer to the Procedures for port State control adopted by the Organization by resolution A.787(19) and amended by A.882(21); see IMO sales publication IMO-650E.

\* The criteria are based on those developed by the United Nations Globally Harmonized System of Classification and Labelling of Chemicals (GHS) as amended.  
For definitions of acronyms or terms used in this appendix, refer to the relevant paragraphs of the IMDG Code.

**Category: Chronic 1**

96 hr LC <sub>50</sub> (for fish)	≤ 1 mg/l and/or
48 hr EC <sub>50</sub> (for crustacea)	≤ 1 mg/l and/or
72 or 96 hr ErC <sub>50</sub> (for algae or other aquatic plants)	≤ 1 mg/l

and the substance is not rapidly degradable and/or the log K<sub>ow</sub> ≥ 4 (unless the experimentally determined BCF < 500).

**Category: Chronic 2**

96 hr LC <sub>50</sub> (for fish)	>1 to ≤ 10 mg/l and/or
48 hr EC <sub>50</sub> (for crustacea)	>1 to ≤ 10 mg/l and/or
72 or 96 hr ErC <sub>50</sub> (for algae or other aquatic plants)	>1 to ≤ 10 mg/l

and the substance is not rapidly degradable and/or the log K<sub>ow</sub> ≥ 4 (unless the experimentally determined BCF < 500), unless the chronic toxicity NOECs are > 1 mg/l.

\*\*\*



## ANNEX 14

**TIMEFRAME LEADING TO THE ENTRY INTO FORCE OF THE  
AMENDED ANNEX III TO MARPOL 73/78**

<b>No.</b>	<b>Action</b>	<b>Meeting</b>	<b>Date</b>	<b>Remarks</b>
1	<i>Agree to</i> amendments to Annex III to MARPOL 73/78	DSC 10	September 2005	
2	<i>Approve</i> amendments to Annex III to MARPOL 73/78	MEPC 54	March 2006	Submit to MEPC 55 under the six-month rule as per MARPOL article 16
3	<i>Adopt</i> amendments to Annex III to MARPOL 73/78	MEPC 55	October 2006	
4	<i>Acceptance</i> of amendments to Annex III to MARPOL 73/78		*1 July 2009 (August 2007)	Not less than 10 months, from the date of adoption, required as per MARPOL article 16
5	<i>Agree to</i> amendment 34-08 to the IMDG Code incorporating amended Annex III	DSC 12	September 2007	Submit to MSC 84 under the six-month rule as per SOLAS article VIII
6	<i>Adopt</i> amendment 34-08 to the IMDG Code	MSC 84	May 2008	
7	<i>Voluntary</i> application of amendment 34-08 to the IMDG Code incorporating amended Annex III		1 January 2009	To facilitate global application of amendments to all modal instruments
8	<i>Acceptance</i> of amendment 34-08 to the IMDG Code incorporating amended Annex III		*1 July 2009	Not less than 12 months, from the date of adoption, required as per SOLAS article VIII
9	<i>Entry into force</i> of amendment 34-08 to the IMDG Code incorporating amended Annex III		1 January 2010	Not less than 6 months from the date of acceptance as per MARPOL article 16 and SOLAS article VIII

\*\*\*

---

\* Deemed acceptance in August 2007 or on 1 July 2009 to coincide with date of acceptance of IMDG Code under SOLAS.





**ANNEX 15**

**PROPOSED AMENDMENTS TO THE CONDITION ASSESSMENT SCHEME  
(RESOLUTION MEPC.94(46), AS AMENDED)**

**PROPOSED AMENDMENTS TO CAS  
(RESOLUTION MEPC.94(46), AS AMENDED)**

1 In Table 7.3.3, at the end of the entry “.1 Each deck plate”, the following text is added: “(see note)”.

2 A note is added below Table 7.3.3 as follows:

“Note:

In conjunction with thickness measurement procedures, in case of concern regarding residual throat thickness of the fillet weld between the deck plate and deck longitudinals or possible detachment of a deck longitudinal member, the attending surveyor may refer to the Guidelines on the assessment of residual fillet weld between deck plating and longitudinals adopted by resolution MEPC.147(54).”

3 The annex to resolution MEPC.94(46), as amended, is further amended by deleting and replacing the existing paragraphs 13.8, 13.9 and 13.10 with the following new paragraphs:

“13.8 The flag Administration may consider and declare that the Statement of Compliance of a ship entitled to fly its flag remains valid and in full force and effect if:

- .1 a change in ownership of the ship should occur; or
- .2 there is a change in the recognized organization from the recognized organization that performed the CAS survey work and prepared the CAS final report, which was reviewed and accepted by the Administration for the issuance of the Statement of Compliance by the Administration, to a new recognized organization acceptable to the Administration, and that all information required to be submitted under the requirements of this resolution has been provided to the new recognized organization, or
- .3 the safe operation and maintenance of the ship is assumed by a Company, as defined in SOLAS chapter IX, other than the one that was operating the ship at the time of the completion of the CAS survey; or
- .4 any combination of 13.8.1, 13.8.2 and 13.8.3 should simultaneously occur;

provided the Administration:

- .5 maintains the same period of validity; and
- .6 co-ordinates the transmittal of specific information, requirements, and procedures concerning the maintenance of the validity of the CAS Statement of Compliance in question to the new owner and/or

Company, which shall remain those adopted by the Administration at the time of the issue of the original Statement of Compliance.

13.9 The Administration shall suspend and/or withdraw the Statement of Compliance of a ship if it is no longer considered to be compliant with the requirements of the CAS.

13.10 The Administration may reinstate a suspended and/or withdrawn Statement of Compliance when it is satisfied that the requirements of the CAS are again being met, but not beyond the limits of the period and the terms and conditions of validity of the Statement of Compliance previously established by the Administration.

13.11 The Administration shall withdraw the Statement of Compliance of a ship if it is no longer entitled to fly its flag.

13.12 If a ship to which a valid Statement of Compliance has already been issued is transferred to the flag of another Party, the new Administration may consider issuing a new Statement of Compliance to that ship on the basis of the Statement of Compliance issued by the previous Administration, provided that the new Administration obtains from the previous Administration:

- .1 a certified copy of the Statement of Compliance that the ship was issued with at the time of the transfer;
- .2 a statement certifying that the RO, which provided the CAS Final Report to the previous Administration, is an RO authorized to act on its behalf;
- .3 a status report from the RO that provided the CAS Final Report to the previous Administration that, at the time of transfer, all the terms and conditions justifying the issuance of the Statement of Compliance to that ship are still valid and being maintained; and
- .4 a copy of both the CAS Final Report and the complete Review Record of all the CAS documentation relating to that ship, which the previous Administration has compiled for the issue or renewal and the maintenance of the validity of the Statement of Compliance that the ship was issued with at the time of the transfer.

13.13 With a change of flag, for the issuance of an Interim Statement of Compliance issued for a period of not more than 90 days to allow the continued operation of the ship while the new Administration performs a technical review and assessment of the CAS Final Report and Review Record, the new Administration shall need only to depend upon the certifications and status report referred to in paragraph 13.12 and provided by the previous Administration and the responsible RO.

13.14 On satisfactory completion of the technical review and assessment of the CAS Final Report and Review Record by the new Administration, under the circumstance of a change of flag as described in paragraph 13.12, a full term Statement of Compliance may be issued by the new Administration limited to the period and no less than the terms and

conditions of validity of the Statement of Compliance issued by the previous Administration. In the event the review is unsatisfactory, the new Administration shall revert to the provisions of paragraphs 13.9 and 13.10.

13.15 Should a change of flag take place during the course of a CAS survey, the new Administration shall determine at what point in the CAS Schedule provided in annex 3 to MEPC/Circ.390 and under what conditions it will assume responsibility for and allow the CAS survey to continue. Sufficient documentation should be provided by the shipowner and the responsible RO to the new Administration upon which to make its decision.”

\*\*\*



**ANNEX 16****RESOLUTION MEPC.147(54)****Adopted on 24 March 2006****GUIDELINES ON THE ASSESSMENT OF RESIDUAL FILLET WELD  
BETWEEN DECK PLATING AND LONGITUDINALS**

THE MARINE ENVIRONMENT PROTECTION COMMITTEE,

RECALLING Article 38(a) of the Convention on the International Maritime Organization concerning the functions of the Marine Environment Protection Committee (the Committee) conferred upon it by international conventions for the prevention and control of marine pollution,

NOTING the Condition Assessment Scheme, as a mandatory requirement for oil tankers operating under the provisions of regulations 13G and 13H of MARPOL Annex I (regulations 20 and 21 of the revised MARPOL Annex I), adopted by resolution MEPC.94(46), as amended,

RECOGNIZING the convenience to provide guidance for inspection of fillet weld between deck plating and longitudinals in connection with thickness measurements requirements as called for in paragraph 7.3.3 and table 7.3.3 of the Condition Assessment Scheme adopted by resolution MEPC.94(46), as amended,

HAVING CONSIDERED, at its fifty-fourth session, the recommendation made by the Sub-Committee on Ship Design and Equipment to adopt the Guidelines on the assessment of residual fillet weld between deck plating and longitudinals,

1. ADOPTS the Guidelines on the assessment of residual fillet weld between deck plating and longitudinals, as an optional provision referred to in Table 7.3.3 of the Condition Assessment Scheme, the text of which is set out in the Annex to this resolution;
2. INVITES Governments to bring the Guidelines to the attention of surveyors, recognized organizations and any other interested parties when carrying out thickness measurements during the conduct of CAS surveys.

## ANNEX

### **GUIDELINES ON THE ASSESSMENT OF RESIDUAL FILLET WELD BETWEEN DECK PLATING AND LONGITUDINALS**

#### **1 General**

The purpose of the guidelines is to provide an evaluation method and criteria for residual throat thickness for the fillet weld between the deck plate and deck longitudinals in order to prevent collapse accidents of aged oil tankers. To ensure that evaluation of the ship's longitudinal strength is recognized as valid, the fillet weld between longitudinals and deck should be in sound condition.

#### **2 Extent of measurement**

Thickness measurement on deck should be carried out according to paragraph 3 of these guidelines i.e. in every other deck longitudinal for three transverse sections, within the cargo area, as given in Table 7.3.3, paragraph 1.2, of the Condition Assessment Scheme (resolution MEPC.94(46), as amended). For areas in tanks where environmental conditions seem to be similar, the extent of this thickness measurement may be specially considered by the attending surveyor.

#### **3 Local thickness measurement and criteria**

##### **3.1 Method of local thickness measurement**

3.1.1 The extent of local measurement should be set within approximately 50 mm of each side of the baseline, as shown in Figure 1.

3.1.2 Within the extent of local measurement, at least five points should be arranged, including one point on the baseline and with approximately 25 mm spacing at maximum. Thereby, the local thickness distribution for the deck plate can be obtained for the target longitudinal.

3.1.3 From the measured thickness distribution, a representative thickness diminution ( $\Delta t$ ), defined by the following equation (1), should be estimated from the measured data on the baseline and the minimum thickness value among the other points:

$$\Delta t = t_0 - \text{Min.}\{t_1, t_2, t_3, t_4\} \quad (1)$$

Where:

$t_0$ : measured thickness on the baseline which is nearly equal to original thickness minus corrosion diminution for deck upper surface ( $\Delta t_0$ ) as shown in figure 1;

$t_1, t_2, t_3, t_4$ : thickness on each measuring point; and

$\Delta t$ : representative thickness diminution, which is assumed to be nearly equal to the diminution of the fillet weld throat thickness.

3.1.4 An estimated residual throat thickness is determined by:

$$r_{\text{residual}} = r_{\text{original}} - \Delta t$$

where  $r_{\text{original}}$  is the original throat thickness at the weld.

### 3.2 Criteria

When the estimated residual throat thickness is zero or less than zero, repair or renewal of the weld should be considered also based on the result of the close-up survey.

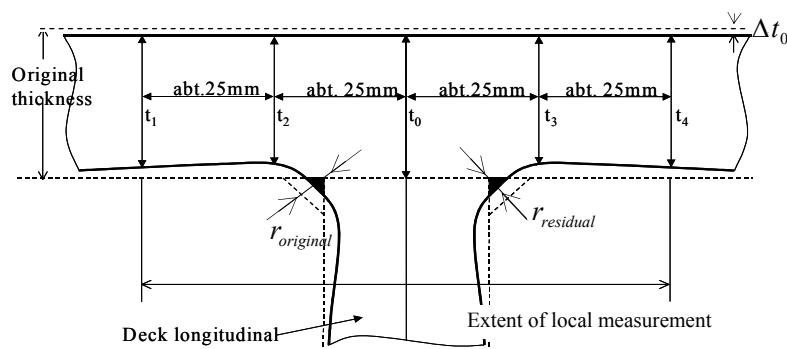
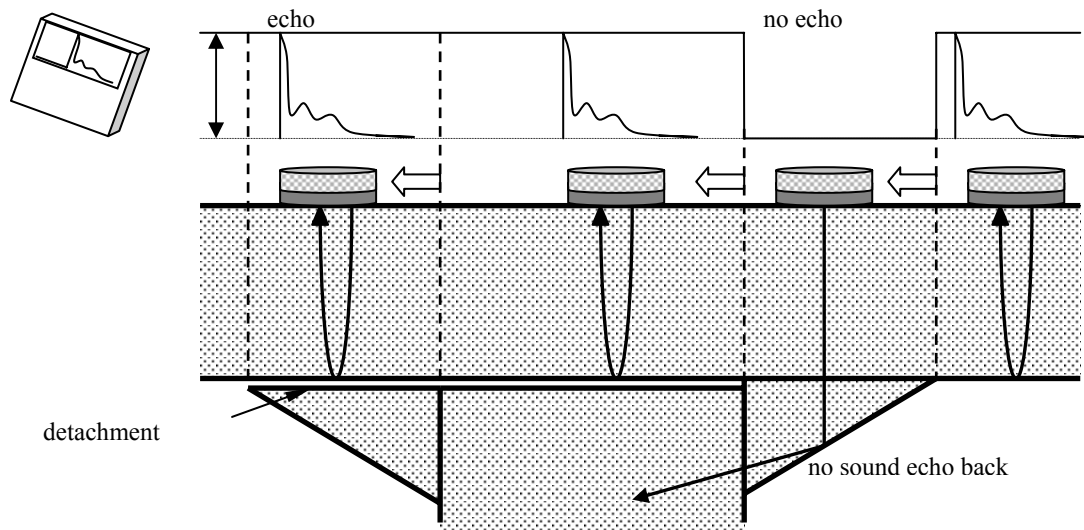

Figure 1 – Thickness measurement at deck plate from upper side

## 4 Alternative method

Detachment of the deck longitudinal member can also be checked using the following procedures. In cases where the longitudinal member is attached in sound condition, when the probe of the ultrasonic equipment is moved from the baseline to the outer side over the welding part, the ultrasonic echo from the bottom surface of the deck plate is not observed just over the welding part. However, in cases where the longitudinal member is detached from the deck plate, when the probe of the ultrasonic equipment is moved from the baseline to the outer side beyond the welding part, the ultrasonic signal echo can be observed continuously, even if the probe is on the detached welding part as shown in figure 2.



**Figure 2 – Alternative method**

\*\*\*



**ANNEX 17****REVISED GUIDELINES FOR SYSTEMS FOR HANDLING OILY WASTES  
IN MACHINERY SPACES OF SHIPS  
INCORPORATING GUIDANCE NOTES FOR AN  
INTEGRATED BILGE WATER TREATMENT SYSTEM (IBTS)**

1 Annex I of the International Convention for the Prevention of Pollution from Ships, 1973, as modified by the Protocol of 1978 relating thereto (MARPOL 73/78), contains certain regulations and unified interpretations related to equipment for the storage, handling and disposal of oily residues and engine-room oily bilge water.

2 In order to facilitate the work of Administrations on systems for handling oily wastes in machinery spaces of ships, the Marine Environment Protection Committee (MEPC) has continuously reviewed an appropriate technology for fulfilment of the Convention requirements.

3 The “Guidelines for systems for handling oily wastes in machinery spaces of ships” appended to MEPC/Circ.235 were developed as guidance for Administrations, shipowners and shipbuilders for consideration in achieving an efficient and effective system for the handling of oily bilge water and oily residues for ships the keels of which are laid on or after 1 January 1992 and, where practicable, ships already in service.

4 The aforementioned Guidelines have been reviewed in accordance with the current provisions of the Convention and revised as set out at annex to this circular.

5 For further prevention of oil pollution from machinery spaces of ships, MEPC considered that the reduction of the generation of oily bilge water generated in machinery spaces is effective and approved the concept of Integrated Bilge Water Treatment System (IBTS) which incorporates the means to reduce the amount of oily bilge water and process the oily bilge water and oil residue (sludge) in a holistic manner.

6 MEPC 54 recognized the need to disseminate the concept of IBTS and developed the Guidance notes for IBTS as set out in the appendix to the Guidelines.

## ANNEX

### **REVISED GUIDELINES FOR SYSTEMS FOR HANDLING OILY WASTES IN MACHINERY SPACES OF SHIPS**

1 Annex I of the MARPOL 73/78 contains certain regulations and unified interpretations related to equipment for the storage, handling and disposal of oily residues and engine-room oily bilge water.

2 In the continuous review by the MEPC of appropriate technology for fulfilment of the Convention requirements, substantial information has been collected which is valuable in the design, approval and surveying of installations in engine-rooms for systems handling oily bilge water, and oily residues, but does not form part of the Convention regulations or the related interpretations.

3 The MEPC had decided that this information is, nevertheless, of substantial value to Administrations, shipowners and shipbuilders and, accordingly, decided that the dissemination of the information should be in the format of an MEPC circular.

4 The information contained in these Guidelines should be regarded as guidance in achieving an efficient and effective system for the handling of oily bilge water and oily residues for new buildings and, where applicable and reasonable, for ships which are in service. The information should be considered in conjunction with specific conditions and circumstances, shipowners' and shipbuilders' practices, classification society rules, Administration requirements, etc., applicable to specific ship.

#### **5 Definitions for the purpose of the Guidelines**

5.1 Oily waste means oil residues (sludge) and oily bilge water.

5.2 Oil residue (sludge) means:

- .1 separated sludge, which means sludge resulting from purification of fuel and lubricating oil;
- .2 drain and leakage oil, which means oil resulting from drainages and leakages in machinery spaces; and
- .3 exhausted oils, which means exhausted lubricating oil, hydraulic oil or other hydrocarbon-based liquid which are not suitable for use in machinery due to deterioration and contamination.

5.3 Sludge tanks mean:

- .1 tanks for separated sludge;
- .2 drain and leakage oil tanks; and
- .3 exhausted oil tanks.

5.4 Bilge water holding tanks mean tanks for oily bilge water.

5.5 Regulations referred to in these Guidelines are those contained in Annex I of MARPOL 73/78.

5.6 Oil sludge incinerators are systems serving for incineration of oil sludge generated on board seagoing ships.

Sludge incinerators could be:

- main and auxiliary steam boilers with appropriate oil sludge processing systems;
- heaters of thermal fluid systems with appropriate oil sludge processing systems;
- incinerators with appropriate oil sludge processing systems designed for sludge incineration; or
- inert gas systems with appropriate oil sludge processing systems.

## **6 Collection and storage of oily wastes**

6.1 A sludge tank or tanks are mandatory under regulation 17.

6.2 A bilge water holding tank is arranged to receive the daily generation of bilge water before this water is discharged ashore or discharged through the 15 ppm equipment overboard. A bilge water holding tank is not mandatory, but will enable ships to operate safely during port visits, during operation in special areas and coastal waters and during periods of maintenance of the 15 ppm equipment.

6.3 A bilge water holding tank will also provide additional safeguards in the purification of oily bilge water should quick-separating detergents be used for cleaning purposes.

## **7 Arrangements of oily waste tanks**

7.1 Tanks for the purposes mentioned above should be arranged to satisfy the intended service of the ship.

7.2 Sludge tanks may be separate and independent but may also be combined, as suitable, depending on the size and the service of the ship.

7.3 The merits of arranging an independent tank for the collection of separated sludge should be considered, having regard to the smaller tank volume that needs to have cleaning and heating arrangements and the reduced space requirement for tank capacity that should preferably be arranged above the tank top.

7.4 If a bilge water holding tank is arranged, it should be separate and independent from other tanks for the collection of sludge.

7.5 Ships operating with residual fuel oil of a relative density greater than 0.94 at 15°C should be provided with a bilge water holding tank of adequate capacity and fitted with heating facilities to preheat the oily mixture prior to the discharge of the tank's contents to the sea through or 15 ppm equipment.

## 8 Size of oily waste tanks

8.1 Tanks for collection of oily waste from various functions in the engine-room should have adequate capacity, having regard to the intended type of service of the ship. The information given below will provide guidance in this respect, but all other aspects applicable to the specific vessel trading pattern and time in port should additionally be taken into account.

8.2 The recommended capacity for oil residue (sludge) tanks is specified in the interpretations to regulation 17.

8.3 If an exhausted oil tank is installed, in addition to the requirement under regulation 17, it should be of sufficient capacity to receive lubricating oil or other oils and hydrocarbon-based liquids from engine-room systems being exhausted due to deterioration, contamination or due to maintenance activities. The oil being discharged from the 15 ppm equipment may also be discharged to this tank. For main and auxiliary engines, which require a complete change of the lubricating oil at sea, the capacity of the tank should be determined as 1.5 m<sup>3</sup> for each 1,000 kW engine rating.

8.4 If a drain and leakage oil tank is installed, in addition to the requirement under regulation 17 it may be arranged at several locations in the engine-room. The oil being discharged from the 15 ppm equipment may also be discharged to this tank. The recommended capacity should be as follows:

Main engine rating (kW)	Capacity (m <sup>3</sup> )
up to 10,000	$20 \times D \times p/10^6$
above 10,000	$D \times (0.2 + 7 \times (P-10,000)/10^6)$

where, D = days; the same length of the voyage as used in the interpretation to regulation 17.

P = main engine rating in kW.

8.5 Bilge water holding tanks, if fitted, should have a capacity that provides to the ship the flexibility of operation in ports, coastal waters and special areas, without the need to discharge deoiled water overboard. The operational merit of not having to operate the 15 ppm equipment frequently should also be considered. The capacity of bilge water holding tanks should be as follows:

Main engine rating (kW)	capacity (m <sup>3</sup> )
up to 1,000	1.5
Above 1,000 up to 20,000	$1.5 + (P-1,000)/1,500$
Above 20,000	$14.2 + 0.2 (P-20,000)/1,500$

where, P = main engine rating in kW

## **9 Pumping, piping and discharge systems in machinery spaces**

9.1 On board ships, the propulsion systems of which are operated by heavy fuel oil, the following guidelines are provided for the piping system comprising the plant components for the treatment and storage of oily bilge water, separated sludge, drain and leakage oil and exhausted oil.

9.2 The effluent from the 15 ppm equipment should be capable of being recycled to the bilge or bilge water holding tank.

9.3 If an integral pump is fitted, the discharge should not bypass the 15 ppm equipment.

9.4 The discharge piping system of the 15 ppm equipment should be completely separate from the bilge pumping and ballast water system except the recycling line referred to in paragraph 9.2.

9.5 The ship's discharge pipeline for oily wastes to the standard discharge connection should be separated from the bunker fuel oil.

9.6 The separated dirty water and exhausted control water of fuel oil purifiers should be discharged into a particular tank for this purpose in order to minimize the influx to the tank for separated sludge. This particular tank should be located above the double bottom for the purpose of facilitating its drain without the need of a drain pump. If dirty water and exhausted control water from purifiers is not discharged to a particular tank, and in lieu of this to a tank for separated sludge, the tank should be located above the double bottom for the purpose of the aforementioned draining facilities.

9.7 Piping to and from sludge tanks shall have no direct connection overboard, other than the standard discharge connection required by regulation 19.

## **10 Systems for separated sludge**

10.1 Tanks for separated sludge and their pipework

Tanks for separated sludge, their pipework and pumps should be designed as follows:

10.1.1 Size of tanks

See paragraph 8.

10.1.2 Design of tanks and tank heating systems

The tanks and tank heating systems should be designed to the satisfaction of the Administration.

10.1.3 Tank heating system

Tanks for separated sludge should be equipped with tank heating systems. The heating pipes should be arranged such that, seen from the heating inlet, to start with they are arranged in a way of the boundaries and then across the whole bottom area sufficiently high, in order to avoid being covered totally by sediments in the tank:

The tank heating system should be designed such as to enable heating of the oil sludge up to 60°C.

The suction line from the sludge tank to the pump should be provided with heat tracing.

#### 10.1.4 Pipelines from the heavy fuel oil purifier to the tank

Whenever possible, the sludge tank should be located below the heavy fuel oil purifier. If this is not possible, the sludge tank should be situated close to the heavy fuel oil purifier in such a way that the discharge line to the tank can be installed at the maximum gradient. The pipelines should, wherever possible, be straight or fitted with large radius elbows.

10.1.5 The submersible pump or opening of the suction line should be arranged so that the oil sludge's path to the suction opening is as short as possible, or the sludge tank should be mounted or designed, so that the oil sludge moves down a slope towards the suction opening. The openings should be placed as wide as possible in the frames above the tank bottom in such a way that the oil sludge has free access to the suction line.

#### 10.1.6 Pump and pressure lines

The pump should be suitable for use with high viscosity oil sludge, e.g. "self-priming displacement pump", with suitable means for protection against dry running. It should have a total head of at least 4 bar, and the delivery rate should be determined by applying the formula:

$$Q = V/t \text{ (m}^3\text{/h)}$$

where V is the volume of the sludge tank as calculated by the interpretation to regulation 17. Four hours should be substituted for the time t. However, the pumping capacity should be not less than 2.0 m<sup>3</sup>/h.

The geodetic suction head of the pump should not exceed 3.0 m for ships with main engine rating up to 15,000 kW and 3.5 m for ships greater than 15,000 kW.

The pressure side of the pump should only be connected to the transfer line on deck, to sludge tanks and to the incineration equipment, if provided.

#### 10.1.7 Sludge tank design to facilitate cleaning

Access holes should be arranged so that all areas of the tank can be cleaned. An access hole should be sited on top of the tank to facilitate the use of a portable pump.

#### 10.1.8 Steaming-out lines

The top of sludge tanks should be fitted with steaming-out lines for cleaning.

## **11 Example of an on-board system for oil sludge incineration**

### 11.1 General

In addition to the provision of sludge tanks, another means for the disposal of oil residue (sludge) are oil sludge incinerators.

## 11.2 Oil sludge incinerators

An oil sludge incinerator system is composed of:

- steam boiler or heater of thermal fluid systems or an incinerator;
- oil burner;
- oil sludge processing system; and
- tanks for separated sludge.

## 11.3 Oil sludge processing systems

The oil sludge processing system consists of:

- tank for mixing oil residues with fuel oil (mixing tank);
- oil sludge preheating system;
- filter; and
- homogenization system.

## 11.4 Mixing tank

The mixing tank should be provided in addition to the tank for separated sludge. It should be equipped with suitable drainage facilities. With a view to improving combustibility and calorific value, a fuel oil supply connection should be provided.

## 11.5 Homogenization system

The homogenization system should assure that the entire contents of the mixing tank should be processed into a homogenous and combustible mixture. This system should be put into operation, following adequate draining of the tank. A device for continuous indication and monitoring of the water content of the oil sludge should be provided.

## APPENDIX

### **GUIDANCE NOTES FOR THE INTEGRATED BILGE WATER TREATMENT SYSTEM (IBTS)**

#### **1 Introduction**

1.1 Bilge oily water is generated by the leakage of water and oil from the equipment and piping or maintenance works resulting from the routine operation in machinery space of ships. Such leaked oil and water are usually mixed and collected on the tank top or bilge wells as oily bilge water.

1.2 Oily bilge water shall be treated in accordance with the requirements of Convention. The operation of such treatment, including the operation and maintenance of bilge filtering equipment, is a heavy load of engineers onboard.

1.3 With the revision of the Guidelines and Specifications for Pollution Prevention Equipment for Machinery Space Bilge of Ships adopted by resolution MEPC.107(49), the capability of bilge filtering equipment has been improved. However, the treatment process of oily bilge water with the improved equipment and the engineers' load will be basically unchanged and the amount of oily bilge water generated in ships has not been reduced.

1.4 To promote the prevention of oil pollution from machinery spaces of ships and reduce the load of the engineers onboard, it is effective to minimize the amount of the oily bilge water generated in machinery spaces.

1.5 MEPC 54 noted the design with the concept of Integrated Bilge Water Treatment System (IBTS) which incorporates the means to minimize the amount of oily bilge water and proceed the oily bilge water and oil residue (sludge) as a drastic solution to prevent oil pollution from machinery spaces of ships.

1.6 MEPC 54, in recognizing the need to disseminate the concept of IBTS, agreed to append the Guidance notes on IBTS to the revised Guidelines for systems for handling oily wastes in machinery spaces of ships.

1.7 The purpose of these Guidance notes is to provide shipowners and shipbuilders with information to help the design of the ship incorporating the concept of IBTS.

#### **2 Concept of Integrated Bilge Water Treatment System (IBTS)**

Integrated Bilge Water Treatment System (IBTS) is a system to minimize the amount of the oily bilge water generated in machinery spaces by means to treat the leaked water and oil separately and also provides integrated means to process the oily bilge water and oil residue (sludge).

#### **3 Definitions for the purposes of the Guidance notes**

3.1 Clean drains mean drains resulting from the leakage of equipment used for sea water, fresh water, steam, etc., which are not contaminated by oil.



- 3.2 Oily drains mean drains resulting from the leakage of equipment used for oil.
- 3.3 Oily bilge water means water collected in the bilge wells or the tank top resulting from the unexpected leakage from piping or the maintenance work in machinery spaces, which may be contaminated by oil.
- 3.4 Oil residue (sludge): refer to 5.2 of appendix 1. It includes oily drains.
- 3.5 Bilge primary tank means a pre-treatment unit for separation of oily bilge water.

#### **4 Outline of IBTS**

##### 4.1 Collection of drains

- 4.1.1 Oily drains are collected through the fixed drainage arrangements to sludge tanks.
- 4.1.2 Clean drains are collected through the fixed drainage arrangements to clean drain tanks.
- 4.1.3 Oily drain and clean drain shall be collected separately so as not to contaminate clean drains with oil.

##### 4.2 Pre-treatment of oily bilge water

To avoid feeding excessive oil to oil filtering equipment, oily bilge water in the bilge wells is transferred to the bilge primary tank for pre-separation of oil. The high oil contained water is transferred to sludge tanks and the low oil contained water is transferred to the bilge water holding tank.

##### 4.3 Discharge of oily bilge water

Oily bilge water in the bilge water holding tank is discharged overboard through the oil filtering equipment in accordance with Regulation 16 of the Convention.

##### 4.4 Discharge of clean drains

Clean drains may be discharged overboard directly through the discharge arrangement independent from the system for oily bilge water or oil.

##### 4.5 Treatment of oil residue (sludge)

- 4.5.1 Oil residue (sludge) in sludge tanks is transferred to the waste oil tanks.
- 4.5.2 Water in oil residue (sludge) is vaporized by heating in the waste oil tanks.
- 4.5.3 Oil residue (sludge) is incinerated by the sludge incinerator or discharged to the reception facilities through the standard shore connection.
- 4.5.4 Oily drains from fuel oil systems may be burnt by the boiler as re-generative fuel.

## 5 Additional installations of IBTS

In addition to the installations required by the Conventions, the following installations are required to compose IBTS:

### 5.1 Drainage system

5.1.1 Drip trays or coamings with sufficient depth provided under the equipment used for oil such as diesel engines, burners, pumps, heaters, coolers, filters and tanks to keep spillage of oil.

5.1.2 Drip trays or coamings with sufficient depth provided under the equipment used for water such as pumps, heaters, coolers, filters, tanks, condensers and boilers to keep spillage of water.

5.1.3 Independent drainage arrangements for oil and water to sludge tanks and the clean drain tank.

### 5.2 Pre-treatment unit for oil separation

Bilge primary tank with construction of cascade, which is able to separate oil from oily bilge water by gravity with drainage facilities of the oil on the top as primary separation of oily bilge water. Refer to the example of bilge primary tank shown in Figure 1.

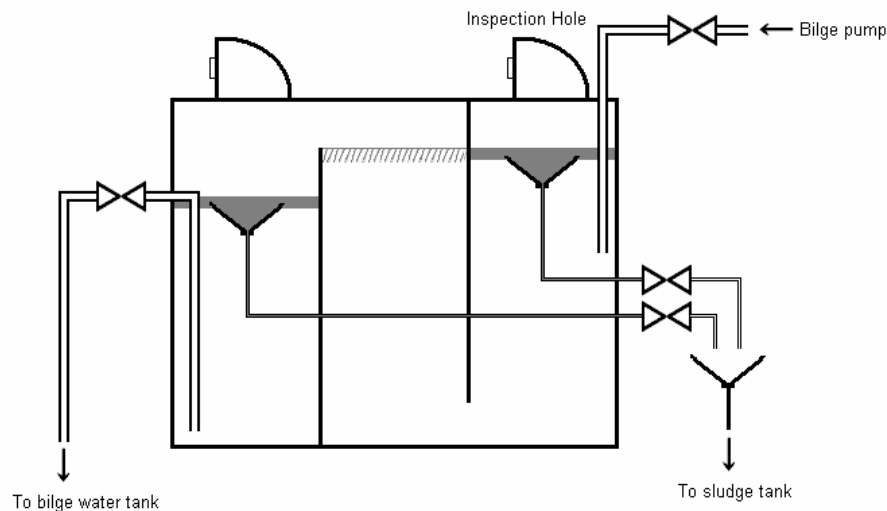

**Figure 1 – Example of bilge primary tank**

### 5.3 Storage tanks

5.3.1 Clean drain tank: Tank for the retention of clean drains.

5.3.2 Bilge water holding tank: Tank for the retention of oily bilge water.

5.3.3 Waste oil tank: Tank for preparation of oil residue (sludge) for incineration.

#### 5.4 Discharge arrangement of clean drains

The discharge arrangement of clean drains to overboard should be independent from the system for oily bilge water.

#### 5.5 Exclusive pump for the oil filtering equipment

It is preferable to be provided with an exclusive pump to transfer the pre-treated bilge water from bilge water holding tank to the oil filtering equipment so as not to mix the pre-treated bilge water and untreated oily bilge water.

#### 5.6 Heating arrangement

5.6.1 Heating arrangement of the bilge primary tank to facilitate separation of oil.

5.6.2 Heating arrangement of the waste oil tank to vaporize water and facilitate incineration.

### **6 Example of IBTS**

A typical flow diagram of IBTS is shown in Figure 2.

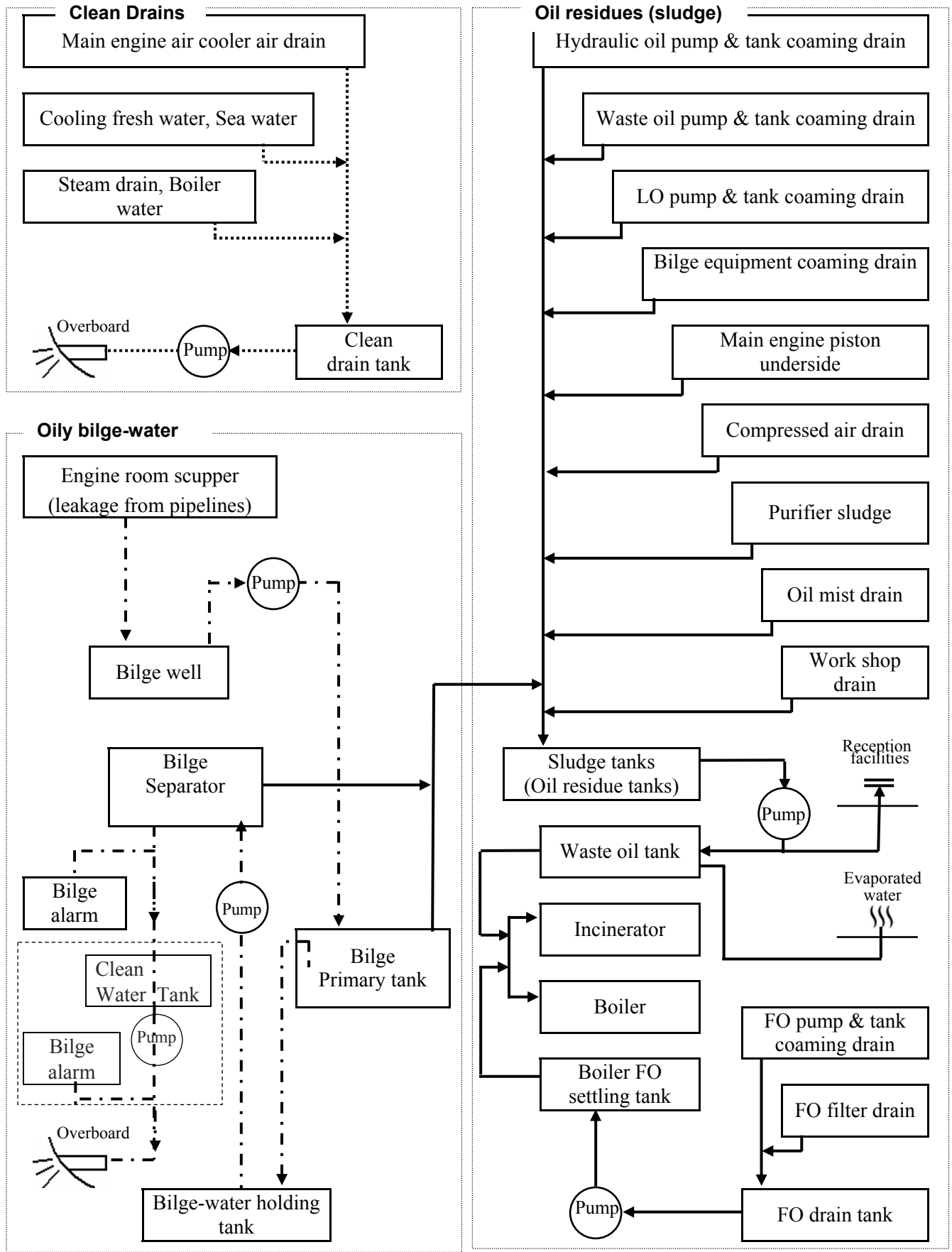

Optional arrangements (not including the IBTS concept)

**Figure 2 – Flow Diagram of Integrated Bilge Water Treatment System (IBTS)**

**ANNEX 18****UNIFIED INTERPRETATION TO REGULATION 25A OF  
THE CURRENT MARPOL ANNEX I***Unified Interpretation 11A.2***Regulation 25A – Intact stability**

For proving compliance with regulation 25A of Annex I to MARPOL 73/78, as an alternative to the loading case described in MARPOL Unified Interpretation 11A it is accepted to carry out an extensive analysis covering all possible combinations of cargo and ballast tank loading. For such extensive analysis conditions, it is considered that:

- .1 weight, centre of gravity co-ordinates and free surface moment for all tanks should be according to the actual content considered in the calculations; and
- .2 the extensive calculations should be carried out in accordance with the following:
  - .2.1 the draughts should be varied between light ballast and scantling draught;
  - .2.2 consumables including but not restricted to fuel oil, diesel oil and fresh water corresponding to 97%, 50% and 10% content should be considered;
  - .2.3 for each draught and variation of consumables, the available deadweight should comprise ballast water and cargo, such that combinations between maximum ballast and minimum cargo and vice versa are covered. In all cases, the number of ballast and cargo tanks loaded should be chosen to reflect the worst combination of VCG and free surface effects. Operational limits on the number of tanks considered to be simultaneously slack and exclusion of specific tanks should not be permitted. All ballast tanks should have at least 1% content;
  - .2.4 cargo densities between the lowest and highest intended to be carried should be considered; and
  - .2.5 sufficient steps between all limits should be examined to ensure that the worst conditions are identified. A minimum of 20 steps for the range of cargo and ballast content, between 1% and 99% of total capacity, should be examined. More closely spaced steps near critical parts of the range may be necessary.

At every stage the criteria described in paragraph 2 of regulation 25A should be met.

\*\*\*



**ANNEX 19****REVISED GUIDELINES FOR THE PROVISIONAL ASSESSMENT  
OF LIQUID SUBSTANCES TRANSPORTED IN BULK****REVISED GUIDELINES FOR THE PROVISIONAL ASSESSMENT OF LIQUID  
SUBSTANCES TRANSPORTED IN BULK**

1 Attached hereto are the revised Guidelines for the Provisional assessment of liquid substances transported in bulk which were approved by the Marine Environment Protection Committee at its fifty-fourth (20 to 24 March 2006) session. The present circular supersedes MEPC/Circ.265.

2 The Guidelines were revised as a consequence of the revision of Annex II to MARPOL 73/78 and the consequential amendments to the IBC Code.

3 The Guidelines provide step-by-step procedures of ascertaining the carriage requirements for all products offered for carriage in bulk.

4 Attention is drawn to the provisions of section 8 of the Guidelines which require that, when a provisional assessment has been made of a pure or technically pure product or mixture containing more than 1% by weight of unassessed components, the manufacturer should submit data to GESAMP/EHS. Based on the data submitted, the product will be evaluated by GESAMP/EHS. After receiving the complete GESAMP Hazard Profile, the manufacturer shall submit to the Administration a completed BLG Product Data Reporting Form including the proposed assessment for Pollution Category and Ship Type and carriage requirements. The Administration shall submit the form and a proposal for a new and complete entry in the IBC Code to IMO.

ANNEX

**GUIDELINES FOR THE PROVISIONAL ASSESSMENT OF  
LIQUID SUBSTANCES TRANSPORTED IN BULK**

Section 1: INTRODUCTION

1.1 The carriage of liquid substances in bulk is regulated by SOLAS 74 as amended and MARPOL 73/78 for safety and pollution prevention purposes.

1.2 Liquid cargoes which may be offered for shipment in bulk can be divided into the following groups:

- .1 liquefied gases;
- .2 oils; and
- .3 noxious and non-noxious liquid substances, hereafter referred to as “products”.

1.3 Liquefied gases are listed in chapter 19 of the IGC Code and their shipment is subject to the provisions of that Code.

1.4 “Oil” means petroleum in any form including crude oil, fuel oil, sludge, oil refuse and refined products (other than those petrochemicals which are subject to the provisions of Annex II of the present Convention) and, without limiting the generality of the foregoing, includes the substances listed in appendix I to MARPOL Annex I.

1.5 A number of products can be shipped either on gas carriers or on chemical tankers. They are included both in chapter 19 of the IGC Code, marked by an asterisk, and in chapter 17 of the IBC Code.

1.6 Each liquid substance offered for carriage in bulk should be identified as either a *liquefied gas*, or an *oil* or a *product*. These guidelines apply only to liquid substances identified as *products*.

1.7 The requirements for the carriage of products in bulk are defined in the IBC and BCH Codes. The IBC Code applies to chemical tankers built on or after 1 July 1986 and is mandatory under both SOLAS 74 as amended and MARPOL 73/78. The BCH Code applies to those built before 1 July 1986. The latter is mandatory under MARPOL 73/78 and recommended under SOLAS 74 as amended.

1.8 In the present guidelines reference is made to the IBC Code only, for the sake of brevity; however, it implies reference to the BCH Code as well, as applicable.

1.9 The procedures described in the present guidelines are presented in diagram form in appendix 1.



## Section 2: ASSESSED PRODUCTS

- 2.1 If a liquid substance is to be shipped as a product, the shipper should first check whether the product is listed in chapter 17 or 18 of the IBC Code, or in chapter 19 (Index of Products Carried in Bulk) or in the latest edition of MEPC.2/Circular.
- 2.2 A product must be shipped under the product name listed in chapter 17 or 18 of the IBC Code or in the latest edition of MEPC.2/Circular.
- 2.3 The products listed in the IBC Code are mainly pure or technically pure products, including their aqueous solutions.
- 2.4 The list of products in chapters 17 and 18 of the IBC Code will be updated in each consecutive edition.
- 2.5 The Index of Products Carried in Bulk (later referred to as Index) gives most of the commonly used synonyms of the products listed in the IBC Code. The Index will also be updated in each consecutive edition of the IBC Code.
- 2.6 If the product is neither listed in chapter 17 or 18 of the IBC Code nor in the Index, the next step is to check the potential entries to chapters 17 and 18 of the IBC Code. Such a list is issued yearly (17 December) as List 1 of the MEPC.2/Circular. The same Circular also includes a list of pollutant only mixtures classified by calculation or assessed as a mixture, List 2 (covered in section 5), a list of trade-named mixtures of assessed products with safety hazards, List 3 (covered in section 6) and a list of pollutant only mixtures with >1 % unassessed components, List 4 (covered in section 7).
- 2.7 If the product is neither listed in the IBC Code, nor published in the MEPC.2/Circular, it is necessary to check whether the product has already been provisionally assessed by tripartite agreement by contacting the Organization.
- 2.8 If a product has already been assessed by tripartite agreement, any newly initiating shipping or producing country should review the basis of the previous assessment with a view to agreeing with the previous assessment. When carrying out this review, new data should be taken into account, if available, so an accurate assessment can be made in accordance with section 4.
- 2.9 If the shipping or producing country is already a Party to a provisional assessment of the product in question, of which one or more of the flag States and/or receiving countries are not Parties, the shipping or producing country will ask them to join in the existing agreement.

### Section 3: UNASSESSED PRODUCTS

3.1 The products to be assessed can be divided into the following groups:

- .1 pure or technically pure products (see section 4);
- .2 pollutant only mixtures containing at least 99% by weight of components already assessed by IMO (see section 5);
- .3 (trade named) mixtures containing at least 99% by weight of components already assessed by IMO, presenting safety hazards (see section 6);
- .4 mixtures containing one or more components, forming more than 1% by weight of the mixture, which have not yet been assessed by IMO (see section 7).

3.2 The products or mixtures referred to in 3.1.1, 3.1.3 and 3.1.4 will be provisionally assessed by tripartite agreement, in accordance with regulation 6.3 of Annex II to MARPOL 73/78.

3.3 Mixtures in 3.1.2 will be assessed in a simplified manner. Due to the purely mechanical nature of such an assessment, it is not necessary for the shipping or producing country to seek the concurrence of the flag States and receiving countries (see section 5). Until the mixture is included in the MEPC.2/Circular, List 2, it is still necessary to inform the flag States and receiving countries on the assessment of the mixture. These mixtures will be shipped under the applicable generic entry to the IBC Code (i.e. Noxious Liquid (n.o.s.) or Non-Noxious Liquid (n.o.s.)).

3.4 Provisional assessments by tripartite agreement will expire after 3 years of publication in the MEPC.2/Circ. It is intended that during this period the product will be assessed by IMO (see section 8). After expiration of a tripartite agreement, no new tripartite agreement for the same product, even under a different name, shall be established.

3.5 It is in the best interest of the manufacturer/shipper to submit the data necessary for a provisional assessment to the shipping or producing country-Administration well in advance of the shipment. The Administration should avoid unnecessary delays in initiating a tripartite agreement, after receiving the complete set of information.

3.6 After the provisional assessment of the products in 3.1.1, 3.1.3 and 3.1.4 is completed, an addendum to the ship's Certificate of Fitness must be issued by the Administration of the flag State of the ship, before the ship sails. An example of an addendum is given in appendix 2.

3.7 Until full agreement for the provisional assessment among Governments involved has been reached, the products shall not be carried.

## Section 4: PROVISIONAL ASSESSMENT OF PURE OR TECHNICALLY PURE PRODUCTS

4.1 In case of pure or technically pure products, the Administration of the shipping or producing country should provisionally assess the Pollution Category, the Ship Type and the carriage requirements, on the basis of the pollution and safety data supplied by the manufacturer/shipper.

### 4.2 **Pollution Aspects**

The following reference documents provide guidance for the Administration to assess the new product's pollution hazard:

- .1 Guidelines for the Categorization of Noxious Liquid Substances (MARPOL 73/78, Annex II, Appendix 1);
- .2 Abbreviated Legend to the revised GESAMP Hazard Evaluation Procedure (MARPOL 73/78, Annex II, Appendix 1); and
- .3 Relevant parts of chapter 21 of the IBC Code: "Criteria for assigning carriage requirements for products subject to the IBC Code", from a marine pollution point of view.

4.3 The first step for the Administration is to check the latest composite list of hazard profiles of substances carried by ships, issued periodically by IMO under cover of a BLG Circular.

4.4 If a hazard profile can be found for the product in question, its Pollution Category should be derived from it in accordance with references 4.2.1. The Ship Type and carriage requirements, in so far as the pollution hazard is concerned, should be derived from references 4.2.3.

4.5 If no hazard profile exists, all the available data to establish a provisional one should be reviewed.

4.6 When adequate data are available, a provisional hazard profile should be derived, following the criteria developed by GESAMP/EHS (see reference 4.2.2). The provisional Pollution Category should be derived from this provisional hazard profile in accordance with 4.2.1. The Ship Type and carriage requirements, based upon its pollution hazard, should be derived in accordance with 4.2.3.

4.7 When sufficient data are not available, the Administration should make an assessment by analogy to chemically similar substances from the following sources:

- .1 the IBC Code including the Index;
- .2 the MEPC.2/Circular referred to in paragraph 2.5, listing the substances assessed by IMO and those provisionally assessed by tripartite agreement; and

- .3 the BLG circular referred to in paragraph 4.3, listing the substances for which a hazard profile exists.

When several alternative analogies are possible, the most severe should prevail.

### **Safety Aspects**

4.8 After assessment of the pollution hazards, the possible safety hazards of the product should be assessed.

4.9 For this assessment reference is made to the relevant parts of chapter 21 of the IBC Code: “Criteria for assigning carriage requirements for products subject to the IBC Code”, from a safety point of view.

4.10 If the product to be provisionally assessed presents a safety hazard, the Administration should assign carriage requirements in accordance with the above-mentioned criteria. These requirements have to be integrated with those previously assigned for pollution prevention purposes only and the most stringent set has to be adopted. If necessary, the Administration should revise the Ship Type previously assigned for pollution considerations only.

### **Administrative Aspects**

4.11 At this point, the Administration of the shipping or producing country, having provisionally assessed the product in question, should seek the concurrence of the Administrations of the Flag State(s) and receiving countries with its evaluation, by providing information on which the provisional pollution and safety hazard assessment has been based. For this purpose, the standard format for proposing tripartite agreements for the provisional assessment of liquid substances, reproduced in appendix 3, should be used.

4.12 In the absence of an interim or final response to the notification from any of the other Parties involved within 14 days of the despatch, the proposed provisional assessment made by the Administration of the shipping or producing country should be deemed to have been accepted. In this respect it should be noted that those contact points which have not informed the Organization of their latest contact details should be deemed to have accepted the tripartite agreements whilst other contact points should still follow regulation 6(3) of Annex II of MARPOL 73/78 and these guidelines (reference is made to resolution MEPC.109(49)).

4.13 In the event of disagreement the most severe conditions proposed should prevail to obtain the tripartite agreement.

4.14 After express or tacit agreement has been reached, the proposing Administration should inform IMO, as required by regulation 6.3 of Annex II (i.e. within 30 days but preferably as soon as possible). It is recommended to use the format, referred to in 4.11, for this purpose.

4.15 After establishing a tripartite agreement, an addendum to the relevant ship’s certificate may be issued.

4.16 The manufacturer should then promptly forward to GESAMP/EHS all data necessary for a formal hazard evaluation (see section 8).

## Section 5: ASSIGNMENT OF POLLUTANT ONLY MIXTURES CONTAINING PRODUCTS ALREADY ASSESSED BY IMO

5.1 This section deals with the mixtures defined in paragraph 3.1.2, i.e. those presenting no safety hazard and containing at least 99% wt of products assessed by IMO. Those products assessed by IMO are limited to:

- .1 those listed in chapters 17 and 18 of the IBC Code;
- .2 those listed in List 1 of the MEPC.2/Circular without an expiry date; and
- .3 those listed in list 5 of the MEPC.2/Circular.

Such a mixture may contain components with safety hazards (designated by “S” or “S/P” in *column d* in chapter 17 of the IBC Code) as long as they are so diluted that the final mixture presents no safety hazard.

5.2 The Pollution Category and the Ship Type of these mixtures are derived from the GESAMP Hazard Profiles of the components by the calculation method in 5.3 and 5.4. For the purpose of this calculation, unassessed components up to 1% should be assigned by the component factor of 10,000 for pollution categorization. For the assignment of the Ship Type the component factor is 100.

### 5.3 Calculation of the Pollution Category

The first step is to establish the Pollution Category of the mixture by the following procedure:

- .1 identify the revised GESAMP Hazard Profile (GHP) of each component from the latest edition of the BLG circulars;
- .2 multiply the concentration of each identified component in the mixture, expressed in percent by weight, by the factor associated with its GHP, taking the ratings resulting in the highest component factor into account, using the following table 1:

Table 1

Row	Rule No (Guidelines for categorization, App. I to Annex II)	A1	A2	B1	B2	D3	E2	Component factor	Row	
a	1	≥4	NR	≥6				100,000	a	
b	1	≥4		≥6				100,000	b	
c	1		NR	≥6				100,000	c	
d	4	≥4	NR			CMRTNI		25,000	d	
e	1			≥6				10,000	e	
f	1	≥4	NR	5				10,000	f	
g	1	≥4		5				10,000	g	
h	1		NR	5				10,000	h	
i	1			5				1,000	i	
j	2	≥4	NR	4				1,000	j	
k	2	≥4		4				1,000	k	
l	3		NR	4				1,000	l	
m	5			4				100	m	
n	11					CMRTNI		25	n	
o	6			3				10	o	
p	7			2				1	p	
q	8	≥4	NR		Not 0			1	q	
r	9				≥1			1	r	
s	10						Fp,F or S if not <del>Inorg</del> Inorganic	1	s	
t	12	Any product not meeting the criteria of rules 1 to 11 and 13							0	t
u	13	Any OS substance							0	u

3 Add the resultant multiples to obtain the value Sp

$$Sp = \Sigma (\text{Each component \%wt}) \times (\text{Each component factor})$$

X  $Sp \geq 25,000$

Y  $Sp < 25,000$  and  $Sp \geq 25$

Z  $Sp < 25$  unless all individual components are OS

OS a mixture where all individual components are OS

Mineral oil\*: component factor for diluent mineral oil in lube oil additives = 100

\* Most lube oil additive components are produced in mineral oil and have been assessed as produced. Sometimes more mineral oil is added to a mixture to make it pumpable. This is called diluent mineral oil.

#### 5.4 Calculation of the Ship Type

The next step is to establish the Ship Type of the mixture by the following procedure:

- .1 identify the Ship Type of each component from the IBC Code or the MEPC.2/Circ;
- .2 multiply the concentration of each component in the mixture, expressed in percent by weight, by the factor associated to its Ship Type according to the following table 2;

Table 2

Ship Type	Factor
1	1,000
2	100
3	10
NA	0
Diluent mineral oil in lube oil additives	10

- .3 add the resultant multiples to obtain the value “Ss”;
- .4 refer to the left-hand column of the flow chart for determining Ship Types and identify the row that corresponds to the value of “Ss”; and
- .5 read across this row, answering the relevant questions in the middle column, to determine the Ship Type for the mixture, as shown in the right-hand column.

Flow Chart for determining Ship Types

Sum of multiples	Question	Answer	Resulting Ship Type
$S_s \geq 10,000$	Is the sum of ST 1 multiples $\geq 10,000$ ?	Yes → No →	1 2
$10,000 > S_s \geq 1,000$	Is the sum of ST 1 & 2 multiples $\geq 1,000$ ?	Yes → No →	2 3
$1,000 > S_s \geq 100$			3
$S_s < 100$	Is the Pollution Category of the mixture X or Y?	Yes → No →	3 NA

5.5 Examples of the calculation of the Pollution Category and the Ship Type of mixtures are given in appendix 6.

5.6 On the basis of the Pollution Category and Ship Type so calculated and of its flash point, a mixture is then assigned to the appropriate “Noxious (or non-noxious) liquid, n.o.s.” generic entry to the IBC Code with the corresponding carriage requirements.

5.7 A mixture is designated in the shipping document by reference to the appropriate generic n.o.s. entry to the IBC Code, completed by the indication of a trade name and of one component responsible for the assigned Pollution Category. Trade names should not be such as to be confused with generally used chemical descriptions. Components should be identified by their name in either the IBC Code or the MEPC.2/Circular List 1.

5.8 With reference to the diluent mineral oil which could be responsible for the final Pollution Category being assigned to a lube oil additive mixture, the designation of the mixture should include “contains mineral oil”.

5.9 The process of assigning a pollutant-only mixture of assessed components to one of the generic n.o.s. entries to the IBC Code is of a purely mathematical nature and does not involve any assessment whatsoever. In the interest of facilitating shipments, the Administration may authorize the manufacturer to carry out the assignment on its behalf.

5.10 In this case, the obligation to inform the flag States and the receiving countries of the performed assignment falls on the delegated manufacturer. The manufacturer should also inform IMO if so requested by the authorizing Administration. Notification of the assignment by the manufacturer should be accompanied by the authorization letter indicating that the manufacturer acts under instruction and on behalf of the Administration until such authorization is recorded in the MEPC.2/Circular. After notification the mixture shall be recorded in the next edition of the MEPC.2/Circular List 2.

5.11 The manufacturer should inform the authorizing Administration of the assignment performed along with the details of the assignment. Upon request, the manufacturer should also provide the flag State and/or the receiving country with details of the mixture assignment.



## Section 6: ASSESSMENT OF (TRADE NAMED MIXTURES PRESENTING SAFETY HAZARDS CONTAINING ONLY PRODUCTS ALREADY ASSESSED BY IMO

6.1 This section deals with the mixtures defined in paragraph 3.1.3, i.e. those presenting a safety hazard (one or more of the components designated by S or S/P) and containing at least 99% wt of products assessed by IMO.

Products assessed by IMO are limited to:

- .1 those listed in chapters 17 and 18 of the IBC Code; and
- .2 those listed in List 1 of the MEPC.2/Circ. without an expiry date; and
- .3 those listed in List 5 of the MEPC.2/Circ.

These mixtures contain components with safety hazards (designated by an “S” or “S/P” in *column d* of chapter 17 of the IBC Code) to such an extent that they impart a safety hazard to the final mixture.

6.2 The Pollution Category of these mixtures is calculated, as shown in paragraph 5.3.

6.3 A tentative Ship Type, for pollution prevention purposes only, is then calculated, as shown in paragraph 5.4.

6.4 The Administration should then provisionally assess the safety hazards of the mixture and assign carriage requirements. The minimum carriage requirements of each column in the Code is determined by selecting the most stringent requirement of the components present in the mixture, unless the Administration is satisfied that safe carriage is ensured by less stringent conditions. The hazards of the mixture must not exceed the hazards of any individual component (synergistic effects). If necessary, the Administration should revise the tentative Ship Type assigned in paragraph 6.3.

6.5 These mixtures, presenting safety hazards, cannot be shipped under Noxious Liquid n.o.s. generic entries in the IBC Code. Therefore, an appropriate shipping name will need to be assigned to the mixture. This will identify the principal substances responsible for the safety and pollution (if applicable) hazards of the mixture and may include its trade name.

6.6 The Administration should now proceed to obtain a tripartite agreement and to inform IMO, as indicated in paragraphs 4.11, 4.12, 4.13 and 4.14. The provisional assessment will be valid for 3 years.

6.7 The shipping name, Pollution Category, Ship Type and carriage requirements provisionally assigned by tripartite agreement will be evaluated by IMO based on information in the BLG data reporting form submitted by the Administration of the producing or shipping country for final inclusion of the mixture in the MEPC.2/Circular List 3 without an expiry date.

## Section 7: ASSESSMENT OF MIXTURES CONTAINING ONE OR MORE COMPONENTS WHICH HAVE NOT YET BEEN ASSESSED BY IMO

7.1 This section deals with the mixtures defined in paragraph 3.1.4, i.e. those containing one or more components, forming more than 1% .wt of the mixture, which have not yet been assessed by IMO and therefore are not listed in either chapters 17 or 18 of the IBC Code, or in the MEPC.2/Circular.

7.2 There are two alternative ways of assessing these mixtures:

- .1 If sufficient data are available on the mixture as a whole, it should be assessed as if it were a pure or technically pure product, as shown in section 4.
- .2 If sufficient data on the mixture as a whole are not available, the producing or shipping country Administration should first provisionally assess each unassessed component according to section 4 and then assess the mixture by calculation, as shown in section 5 for a pollutant only mixture and section 6 for trade named mixtures presenting safety hazards.

7.3 Mixtures presenting pollution hazards only

7.3.1 After provisional assessment by tripartite agreement, pollutant-only mixtures containing unassessed components will be shipped under one of the “Noxious (or non-noxious) liquid, n.o.s.” generic entries to the IBC Code, without the need for an addendum to the ship’s Certificate of Fitness.

7.3.2 The Administration of the producing or shipping country should inform IMO on the results of the tripartite agreement within 30 days. The results will be included in the next edition of the MEPC.2/Circ, List 4.

7.3.3 The manufacturer will forward to GESAMP/EHS the available data on the mixture as a whole in the case of 7.2.1 or on each individual unassessed component in the case of 7.2.2, in order to assess the respective Hazard Profiles. This should be done as soon as possible, using the format reproduced in annex 8.

7.4 Mixtures presenting safety hazards

7.4.1 When an unassessed component shows safety hazards, the Administration of the producing or shipping country should follow the procedure set out in Section 4, as if the component is to be shipped as a pure or a technically pure product.

7.4.2 When a tripartite agreement is reached for the component in 7.4.1, follow the procedure set out in Section 6.

7.4.3 Provisionally assessed mixtures presenting safety hazards will be included in the List 3 of MEPC.2/Circular with an expiry date of three years.

7.5 The manufacturer will forward to GESAMP/EHS the available data on the mixture as a whole in the case of 7.2.1 or on each individual unassessed component in the case of 7.2.2, in order to assign the respective Hazard Profiles. This should be done as soon as possible, using the format reproduced in annex 8.

## Section 8: SUBMISSION OF DATA TO GESAMP/EHS AND IMO

8.1 As soon as possible after a provisional assessment has been made of a pure or technically pure product or of a mixture containing more than 1% by weight of unassessed components, the manufacturer should submit to the GESAMP/EHS\* Technical Secretariat the data required to develop a hazard profile of the substance or component or mixture, using the format shown in Annex 7 of GESAMP Reports and Studies No 64.

8.2 After receiving the complete GESAMP Hazard Profile, the manufacturer shall submit to the Administration a completed BLG Product Data Reporting Form based on the assessed product by GESAMP/EHS and, where possible, including the proposed assessment for Pollution Category and Ship Type and carriage requirements. The Administration should submit a proposal including the form for a new and complete entry in the IBC Code to IMO. A format of the BLG Product Data Reporting Form is shown in appendix 4 and can be downloaded from [www.imo.org](http://www.imo.org) *click on* Marine Environment *click on* Chemicals reporting forms *click on* BLG Product Data Reporting Form.

8.3 Unless such a substance, component or mixture will have been evaluated by the GESAMP/EHS and IMO in the meantime, its provisional assessment by tripartite agreement will cease to be valid 3 years after the date of publication in the MEPC.2/Circular. After expiration of a tripartite agreement, no new tripartite agreement for the same product, even under a different name, shall be established.

---

\* The completed form should be sent to:

The Technical Secretary of GESAMP/EHS Working Group  
International Maritime Organization (IMO)  
4 Albert Embankment  
London SE1 7SR  
United Kingdom

Appendix 1

Scheme 1

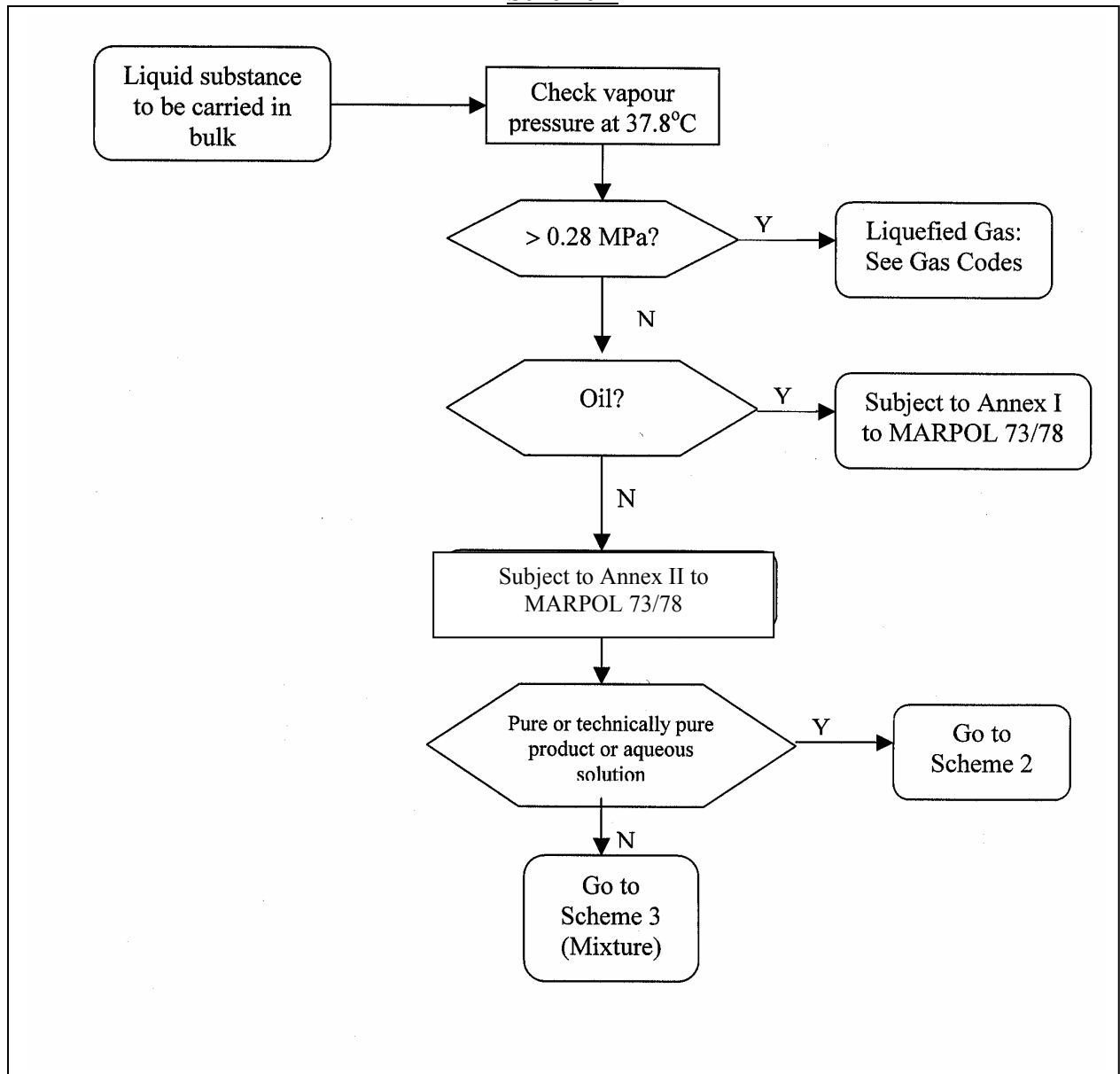

Scheme 2

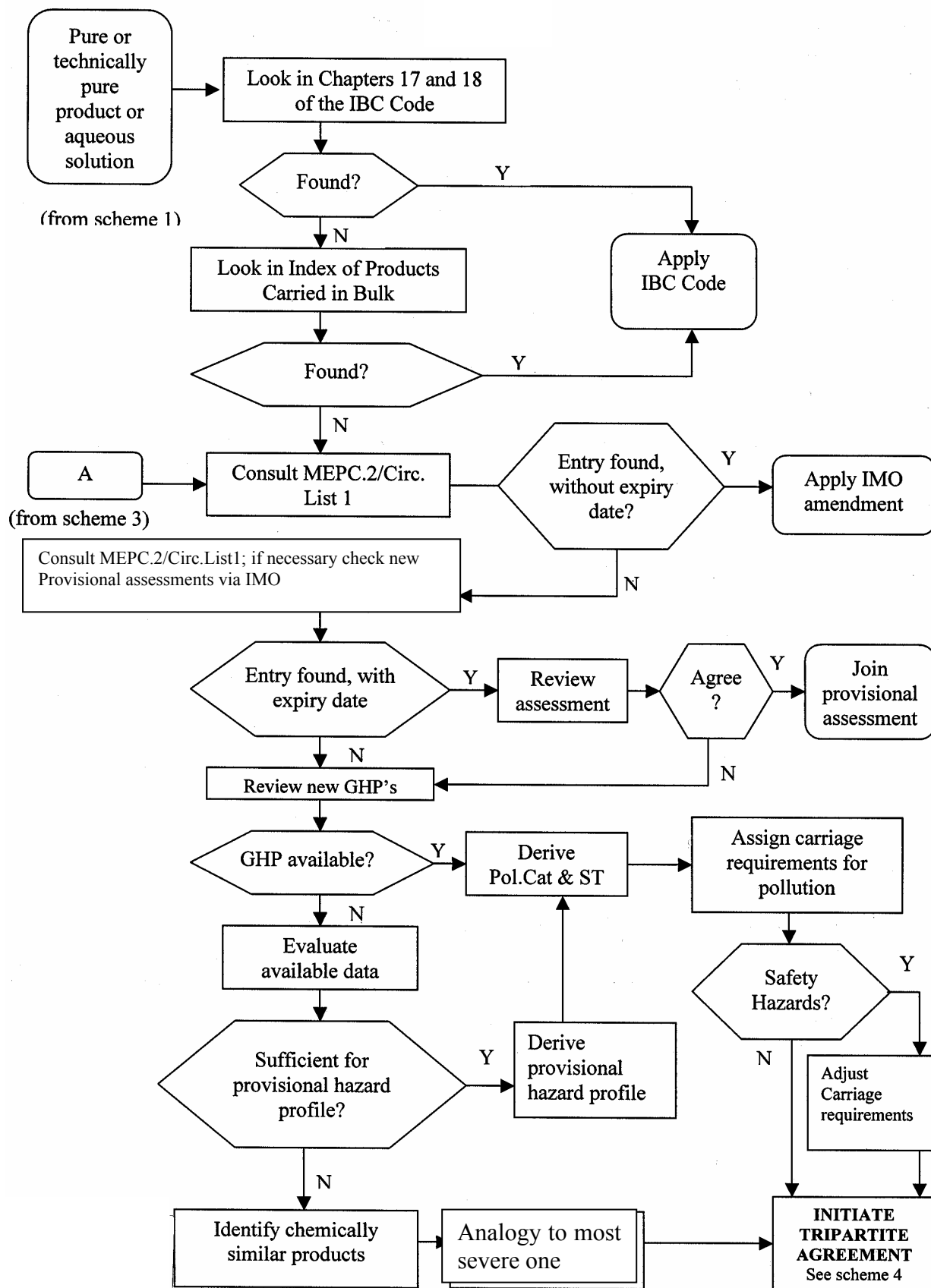

Scheme 3

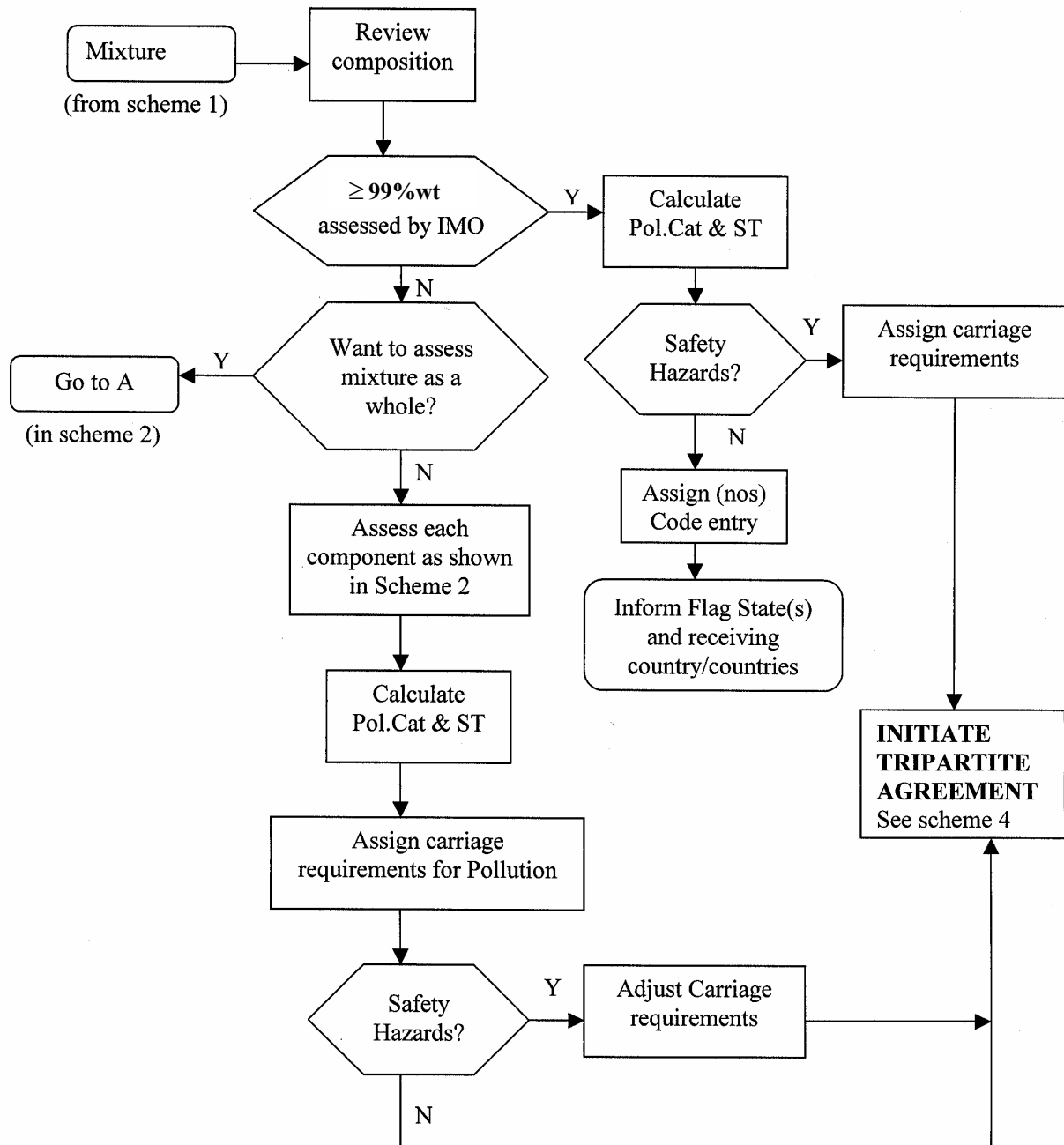

Scheme 4

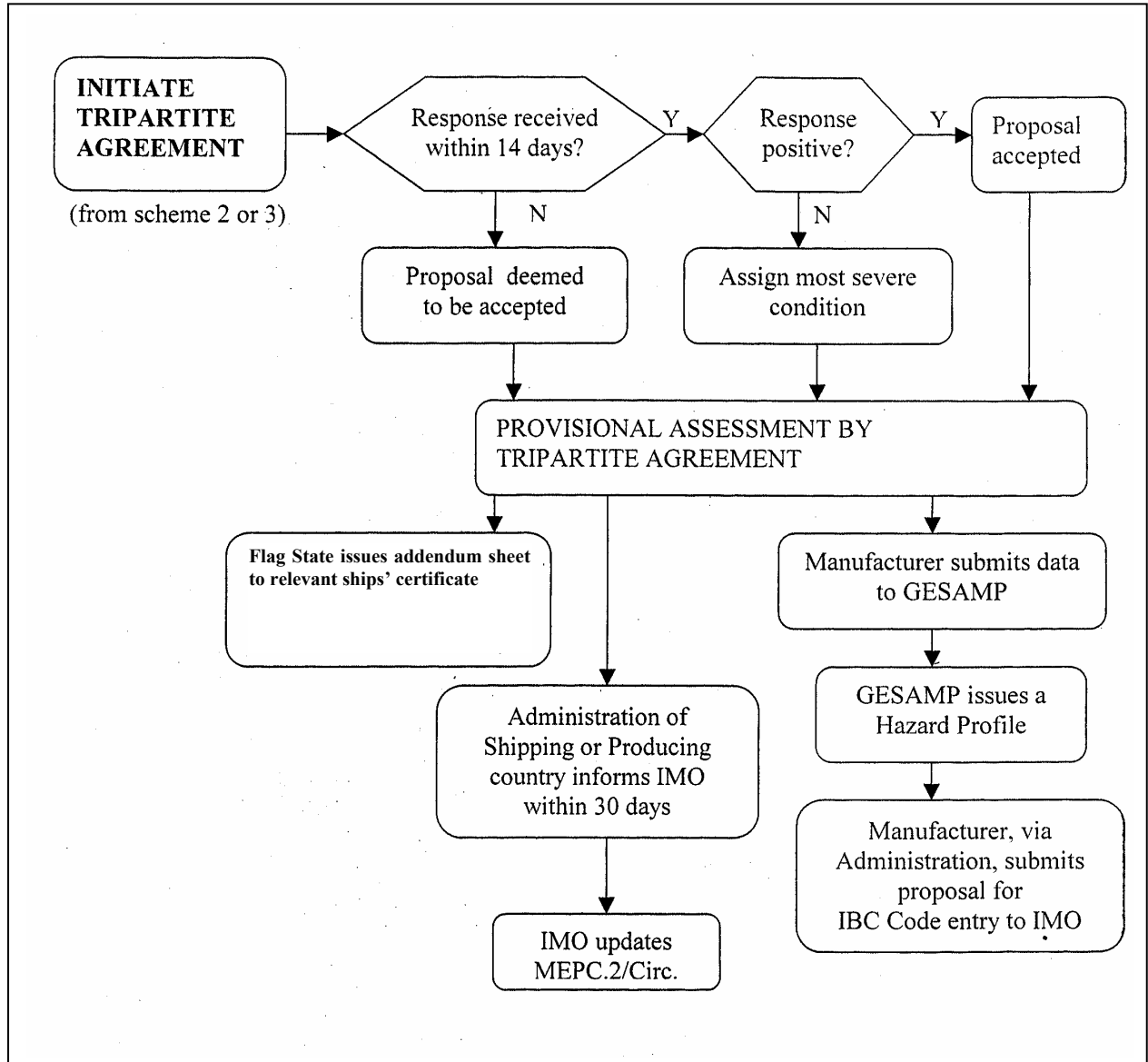



Appendix 2

EXAMPLE OF AN ADDENDUM TO THE SHIP'S CERTIFICATE OF FITNESS /  
INTERNATIONAL CERTIFICATE OF FITNESS / INTERNATIONAL POLLUTION  
PREVENTION CERTIFICATE FOR THE CARRIAGE OF NOXIOUS LIQUID  
SUBSTANCES IN BULK\*

Addendum to Certificate No.:			Issued at: dd/mm/yyyy		
Issued in pursuance of the Code for the Construction and Equipment of Ships Carrying Dangerous Chemicals in Bulk /International Code for the Construction and Equipment of Ships Carrying Dangerous Chemicals in Bulk / Annex II to MARPOL 73/78 as amended* under the authority of the Government of: <p style="text-align: center;">.....</p>					
Name of Ship	Distinctive Number or Letters	IMO Number	Port of Registry	Gross Tonnage	Ship Type

**THIS IS TO CERTIFY:**

That the ship meets the requirements for the carriage in bulk of the following product(s), provided that all relevant operational provisions of / the Code and / Annex II of MARPOL 73/78 are observed:

Noxious Liquid Substance / Product*	Conditions of carriage (tank numbers, etc.)	Pollution Category

The transportation of this product is permitted between the following countries:

The issuance of this Addendum is based on document:

The Tripartite Agreement for this product is valid until: (dd/mm/yyyy).....

This Addendum will remain in force until: (dd/mm/yyyy).....

Place and date of issue: (dd/mm/yyyy).....

Signed.....  
(signature of authorized official)

---

\* Delete as appropriate.

Appendix 3

**FORMAT FOR PROPOSING TRIPARTITE AGREEMENTS FOR PROVISIONAL  
ASSESSMENT OF LIQUID SUBSTANCES**  
(for insertion in lists 1, 3 or 4 of the MEPC.2/Circ.)

Name of Product:  
proposed for inclusion in list: \_\_\_\_\_ of MEPC.2/Circ.

Proposed pollution hazard profile:

A1	A2	B1	B2	D3	E2

Pollution hazard profile based on: by analogy to  
resulting in proposed Pollution Category: \_\_\_\_\_ and Ship Type (pollution hazard):

Additional information regarding pollution aspects:

Melting/pourpoint: \_\_\_\_\_ ° C (specify):  
Viscosity (mPa.s) at 20 ° C:

Safety information:

Vapour pressure (Pa): \_\_\_\_\_ at \_\_\_\_\_ ° C Boiling point: \_\_\_\_\_ ° C

Flashpoint (c.c): \_\_\_\_\_ ° C

Density: \_\_\_\_\_ (kg/m<sup>3</sup>)

Relevant toxicity: Acute inhalation toxicity\* (LC<sub>50</sub>; mg/l/4hr):  
Acute dermal toxicity (LD<sub>50</sub>; mg/kg):  
Acute oral toxicity (LD<sub>50</sub>; mg/kg):  
Corrosivity to skin (skin necrosis):

Chemical properties: Solubility in water (mg/l):  
Autoignition temperature: \_\_\_\_\_ ° C  
Explosive/flammability range (% v/v):  
Hazardous reaction control necessary: \_\_\_\_\_ water  
Corrosive to steel:

---

\* The criteria for inhalation toxicity are based on LC<sub>50</sub> data relating to 4 hr exposures: where such information is available it should be used. Where LC<sub>50</sub> data relating to 1 hr exposures are available, such values can be divided by 4 to be considered equivalent to LC<sub>50</sub> (4hr).

Column		Column		Column	
d		i		l	
e**		i		m	-deleted-
f		i		n	
g		j		o	
h		k			

\*\* Ship Type may have been overruled by safety aspects.

Appendix 4

**BLG Product Data Reporting Form**

( Characteristics of Products proposed for Bulk Marine Transport )

**1: Product Identity**

**Product Name:**

The product name shall be used in the shipping document for any cargo offered for bulk shipments. Any additional name may be included in brackets after the product name.

**1.1: Other Names and Identification Numbers**

**Main Trade Name** :

**Main Chemical Name** :

**Chemical Formula** :

**C.A.S Number** :

**EHS Number** :

**BMR Number** :

**RTECS Number** :

**Structure**

**1.2: Associated Synonyms**

**Synonym Name**

**Type**

<u>Synonym Name</u>	<u>Type</u>

**1.3: Composition**

**Component Name**

**%**

**Type**

<u>Component Name</u>	<u>%</u>	<u>Type</u>

## 2: Physical Properties

Property References and Comments	Units	Qual	Lower Value	Upper Value
Molecular weight		<input type="text"/>	<input type="text"/>	<input type="text"/>
Density @ 20 ° C	( kg/m <sup>3</sup> )	<input type="text"/>	<input type="text"/>	<input type="text"/>
Flash Point (cc)	( ° C )	<input type="text"/>	<input type="text"/>	<input type="text"/>
Boiling Point	( ° C )	<input type="text"/>	<input type="text"/>	<input type="text"/>
Melting Point/Pour Point ( ° C )		<input type="text"/>	<input type="text"/>	<input type="text"/>
Water solubility @	( mg/l )	<input type="text"/>	<input type="text"/>	<input type="text"/>
Viscosity @ 20 ° C	( mPa.s )	<input type="text"/>	<input type="text"/>	<input type="text"/>
Vap. Press. @ 20	( Pa )	<input type="text"/>	<input type="text"/>	<input type="text"/>
AutolgnitionTemp	( ° C )	<input type="text"/>	<input type="text"/>	<input type="text"/>
Explosion Limits	( % v/v )	<input type="text"/>	<input type="text"/>	<input type="text"/>
Carriage Temperature	( ° C )	<input type="text"/>	<input type="text"/>	<input type="text"/>
Unloading Temperature	( ° C )	<input type="text"/>	<input type="text"/>	<input type="text"/>
MESG	( mm )	<input type="text"/>	<input type="text"/>	<input type="text"/>

## 3: Relevant Chemical Properties

Water Reactivity

(0 - 2)

0=No Reactivity

1=Reactive

2=Highly

Details

Does the product react with air to cause a potentially hazardous situation (Y/N)

If so, provide details

Reference

Is an Inhibitor or Stabilizer needed to prevent a hazardous reaction?   
(Y/N)

If so, provide details

Reference

Is refrigeration needed to prevent a hazardous reaction?   
(Y/N)

If so, provide details

Reference

**4: Mammalian Toxicity**

**4.1 Acute Toxicity**

	Qual	Lower Val.	Upper Val.	Species	Reference/ Comments
Oral (mg/kg)	LD50	<input type="text"/>	<input type="text"/>	<input type="text"/>	<input type="text"/>
Dermal (mg/kg)		<input type="text"/>	<input type="text"/>	<input type="text"/>	<input type="text"/>
Inhalation (mg/l/4h)		<input type="text"/>	<input type="text"/>	<input type="text"/>	<input type="text"/>

**4.2 Corrosivity and Irritation**

Skin Corrosion time

	Resultant observation	Species	Reference/Comments
Skin Irritation (4h exposure)	<input type="text"/>	<input type="text"/>	<input type="text"/>
Eye Irritation	<input type="text"/>	<input type="text"/>	<input type="text"/>

Not irritating, Slightly irritating, Mildly irritating, Moderately irritating, Severely irritating or Corrosive

### 4.3 Sensitization

Respiratory (in humans)	Sensitizer	(Y/N)	<input type="checkbox"/>	<input type="checkbox"/>	<input type="text"/>
Skin Sensitization		(Y/N)	<input type="checkbox"/>	<input type="checkbox"/>	<input type="text"/>

### 4.4 Other Specific Long-Term Effects

Carcinogen	(Y/N)	<input type="checkbox"/>	<input type="text"/>
Mutagen	(Y/N)	<input type="checkbox"/>	<input type="text"/>
Toxic to Reproduction:	(Y/N)	<input type="checkbox"/>	<input type="text"/>
Other Long term	(Y/N)	<input type="checkbox"/>	<input type="text"/>

### 4.5 Other Relevant Mammalian Toxicity

## 5: GESAMP Hazard Profiles and Carriage Requirements

### 5.1: GESAMP Hazard Profiles

Column	Property	Value
A1	Bioaccumulation	
A2	Biodegradation	
B1	Acute Aquatic Toxicity	
B2	Chronic Aquatic Toxicity	
C1	Acute Oral Toxicity	
C2	Acute Dermal Toxicity	
C3	Acute Inhalation Toxicity	
D1	Skin Irritation/Corrosivity	
D2	Eye Irritation/Corrosivity	

D3	Specific Health Concerns	
E1	Tainting and Odour	
E2	Wildlife and Seabeds	
E3	Beaches and Amenities	
F	Remarks	

### **5.2: Proposed Carriage Requirements**

Column in the IBC Code	Property	Value
c	Pollution Category	
d	Safety/Pollution Properties	
e	Ship Type	
f	Tank Type	
g	Tank Vents	
h	Tank Environmental Control	
l'	Electrical Equipment – Class	
l''	Electrical Equipment – Group	
l'''	Electrical Equipment – Flashpoint > 60°C	
j	Gauging	
k	Vapour Detection	
l	Fire Protection	
n	Emergency Escape	
o	Special Requirements	



## Appendix 5

### GUIDELINES ON THE COMPLETION OF THE BLG PRODUCT DATA REPORTING FORM

#### 1 General Comments applicable to all sections of the BLG Product Data Reporting Form

1.1 Most properties have the following boxes associated with them:

.1 **Qual:** This is used to provide additional information about the reported value when required. The data used to complete this box must be selected from the following:

- blank No qualification is necessary or appropriate as it is deemed to mean ‘=’
- > Greater than
- < Less than
- ~ Approximately
- E Estimated (this can be used with any of the other qualifiers)
- NF Non-Flammable (used for flash point, autoignition temperature and explosion limits to show that the product is not hazardous).

.2 **Lower Value:** Where only one value exists, it should be put in this box. Where there is a range of values, the lower value should be put in this box e.g. mixtures or impure products have a boiling range rather than a boiling point and so the initial boiling point is put in the **Lower Value** and the dry point is put in the **Upper Value**. For most purposes, the Lower Value will be used and is normally the only one that must be completed, though for **Explosion Limits**, both the **Lower Value** and the **Upper Value** are necessary.

.3 **Reference and Comments:** This should be completed so that the source of data can be traced. This may be a reference to company information, open literature or justification for an estimated value e.g. read across from a similar chemical.

#### 2 Section 1: Product Identity

2.1 This section serves to provide as much identification of the product as possible. It is recognized that some of the boxes may not be relevant, such as the Chemical Abstract Services Number (C.A.S Number) that is normally only applicable to technically pure products or process streams. However, it is advisable to complete this section as much as possible as it facilitates the classification process and provides a mechanism for checking that the product has not been processed under a different name.

2.2 **EHS Number:** This is the reference number issued and used by the GESAMP/EHS Working Group to identify every chemical in its Composite List of products that it has evaluated.

2.3 **BMR Number:** This is the reference number issued and used by IMO to identify every chemical in the IBC Code and the Tripartite Agreements listed in MEPC.2/Circulars.

2.4 **Associated Synonyms:** These are product names, other than those identified in the boxes for **Main Trade Name**, **Main Chemical Name** and **Proper Shipping Name**; they tend to be less common names and should be described in the **Type of Name** section by a qualifier.

2.5 Synonyms in the official languages of IMO should also be included where possible.

2.6 **Composition:** This section shall be used to include components of mixtures and impurities of any product; each entry in this section should include the percentage and Type (described as either C (Component) or I (Impurity)). In situations where this information is confidential, the data should be provided separately to the Reporting State.

### 3 Section 2: Physical Properties

3.1 It is important to recognize that, unless otherwise indicated, **ALL** the physical properties of the product referred to in this section have to be completed in order to enable the correct carriage requirements to be assigned.

3.2 Special attention should be given to paragraph 1.1 of these guidelines when completing this section on physical properties.

3.3 The additional specific notes are applicable to the physical properties section:

- .1 If the product is not flammable then put 'NF' in the Qual box for flash point, autoignition temperature, explosion limits and maximum experimental safe gap (MESG).
- .2 If the flash point is  $>200^{\circ}\text{C}$  and the autoignition temperature has not been measured, it may safely be estimated as  $> 200^{\circ}\text{C}$  which is the cut-off point for defining a product as subject to chapter 17 of the IBC Code.
- .3 For products which do not have a clear melting point, the pour point is regarded as being equivalent. In these cases the reference should include the term '(pour point)'.

### 4 Section 3: Relevant Chemical Properties

#### Water Reactivity Index

4.1 This parameter is an indication of the product's reactivity with water which will result in a hazard. As there are no quantitative definitions for this property, the following guidelines are provided with examples given that can be used for purposes of comparison:

- |       |  |
|-------|--|
| WRI=2 | Applies to any chemical which, in contact with water, may produce a toxic, flammable or corrosive gas or aerosol.                  |
| WRI=1 | Applies to any chemical which, in contact with water, may generate heat producing a non-toxic, non-flammable or non corrosive gas. |
| WRI=0 | Applies to any chemical which, in contact with water, would not undergo a reaction to justify a value of 1 or 2.                   |

## APPENDIX 6

### EXAMPLE OF THE CALCULATION METHOD

#### **Examples of determination of Pollution Categories for mixtures**

##### **Working Method**

###### *Step 1*

Determine for each component the applicable row in Table 1, by means of its hazard profile, taken from the GESAMP/EHS Composite list. This will determine the component factor.

###### *Step 2*

Multiply the component factor with the percentage of the component in the mixture. This will result in the value Sp.

###### *Step 3*

Add all resultant Sp values and determine the Pollution Category.

**Example 1**

*Steps 1 and 2*

The amount of component 1 is 11% of the mixture,  
its GESAMP hazard profile, taken from the GESAMP/EHS Composite list is:

A1	A2	B1	B2	D3	E2
4	NR	6			

This leads to row *a* in Table 1. The component factor is 100,000, the multiple is 1,100,000.

The amount of component 2 is 67% of the mixture,  
its GESAMP hazard profile, taken from the GESAMP/EHS Composite list is:

A1	A2	B1	B2	D3	E2
4	NR	1	1		

This leads to row *q* in Table 1. The component factor is 1, the multiple is 67.

The amount of component 3 is 22% of the mixture,  
its GESAMP hazard profile, taken from the GESAMP/EHS Composite list is:

A1	A2	B1	B2	D3	E2
	R	3			

This leads to row *o* in Table 1. The component factor is 10, the multiple is 220.

*Step 3*

**Sp = 1,100,287**

**Sp ≥ 25,000**

**The mixture is therefore Pollution Category X**

Component number	Applicable row in Table 1	Component Factor (Cp)	%	Multiple (Cp x %)	Resultant Pollution Category
1	a	100,000	11	1,100,000	<b>X</b>
2	q	1	67	67	
3	o	10	22	220	
<b>Sp</b>				<b>1,100,287</b>	

## Example 2

### Steps 1 and 2

The amount of component 1 is 11% of the mixture,  
its GESAMP hazard profile, taken from the GESAMP/EHS Composite list is:

A1	A2	B1	B2	D3	E2
		5		C	

This leads to row *i* in Table 1. The component factor is 1,000, the multiple is 11,000.

The amount of component 2 is 67 % of the mixture,  
its GESAMP hazard profile, taken from the GESAMP/EHS Composite list is:

A1	A2	B1	B2	D3	E2
4	NR		1		

This leads to row *q* in Table 1. The component factor is 1, the multiple is 67.

The amount of component 3 is 22% of the mixture,  
its GESAMP hazard profile, taken from the GESAMP/EHS Composite list is:

A1	A2	B1	B2	D3	E2
		3			

This leads to row *o* in Table 1. The component factor is 10, the multiple is 220.

### Step 3

$$Sp = 11,287$$

$$Sp < 25,000 \text{ and } Sp \geq 25$$

Component number	Applicable row in Table 1	Component factor (Cp)	%	Multiple (Cp x %)	Resultant Pollution Category
1	i	1,000	11	11,000	Y
2	q	1	67	67	
3	o	10	22	220	
<b>Sp</b>				<b>11,287</b>	

The mixture is therefore category Y

### Example 3

#### Steps 1 and 2

The amount of component 1 is 2 % of the mixture,  
its GESAMP hazard profile, taken from the GESAMP/EHS Composite list is:

A1	A2	B1	B2	D3	E2
		3			

This leads to row o in Table 1. The component factor is 10, the multiple is 20.

The amount of component 2 is 4 % of the mixture,  
its GESAMP hazard profile, taken from the GESAMP/EHS Composite list is:

A1	A2	B1	B2	D3	E2
4	NR		1		

This leads to row q in Table 1. The component factor is 1, the multiple is 4.

The amount of component 3 is 94 % of the mixture,  
its GESAMP Hazard profile taken from the GESAMP/EHS Composite list is completely blank or zero:

A1	A2	B1	B2	D3	E2

This leads to row u in Table 1,

It is an OS component, the component factor is 0, the multiple is 0.

#### Step 3

$$Sp = 24$$

$Sp < 25$  and not all components are OS

Component number	Applicable row in Table 1	Component factor (Cp)	%	Multiple (Cp x %)	Resultant Pollution Category
1	o	10	2	20	<b>Z</b>
2	q	1	4	4	
3	u	0	94	0	
<b>Sp</b>				<b>24</b>	

The mixture is therefore category **Z**

**Example 4**

*Steps 1 and 2*

Component 1 is 20% of the mixture,  
its GESAMP Hazard profile, taken from the GESAMP/EHS Composite list is completely  
blank or zero:

A1	A2	B1	B2	D3	E2
		0			

Component 2 is 80% of the mixture,  
its GESAMP Hazard profile, taken from the GESAMP/EHS Composite list is completely  
blank:

A1	A2	B1	B2	D3	E2

All components are OS, *row u* in Table 1 is applicable. The component factors and the  
multiples are 0.

*Step 3*

**$Sp = 0$**

**The mixture consists of OS components only**

Component number	Applicable row in Table 1	Component factor (Cp)	%	Multiple (Cp x %)	Resultant Pollution Category
1	u	0	20	0	<b>OS</b>
2	u	0	80	0	
<b>Sp</b>				<b>0</b>	

**The mixture is therefore OS**

**Example 5**

*Steps 1 and 2*

The amount of component 1 is 70% of the mixture,  
its GESAMP hazard profile, taken from the GESAMP/EHS Composite list is:

A1	A2	B1	B2	D3	E2
		4			

This leads to row *m* in Table 1. The component factor is 100, the multiple is 7,000.

The amount of component 2 is 29% of the mixture.  
It is a diluent mineral oil so *no row* in Table 1 is applicable.  
The component factor however is 100, the multiple is 2,900.

The amount of component 3 is 1% of the mixture.  
It is an unassessed component, so *no row* in Table 1 is applicable.  
The component factor however is 10,000. The multiple is therefore 10,000.

*Step 3*

**$Sp = 19,900$**

Component number	Applicable row in Table 1	Component factor (Cp)	%	Multiple (Cp x %)	Resultant Pollution Category
1	m	100	70	7,000	<b>Y</b>
2	Component is diluent mineral oil	100	29	2,900	
3	Unassessed component	10,000	1	10,000	
<b>Sp</b>				<b>19,900</b>	

**$Sp < 25,000$  and  
 $Sp \geq 25$   
The mixture is  
therefore category  
Y**



### Example 6

#### Steps 1 and 2

The amount of component 1 is 2% of the mixture,  
its GESAMP hazard profile, taken from the GESAMP/EHS Composite list is:

A1	A2	B1	B2	D3	E2
5	NR			M	

This leads to row *d* in Table 1. The component factor is 25,000, the multiple is 50,000.

The amount of component 2 is 98% of the mixture,  
its GESAMP hazard profile, taken from the GESAMP/EHS Composite list is:

A1	A2	B1	B2	D3	E2
			≥1		

This leads to row *r* in Table 1. The component factor is 1, the multiple is 98.

#### Step 3

**Sp = 50,098**

**Sp ≥ 25,000**

**The mixture is therefore category X**

Component number	Applicable row in Table 1	Component factor (Cp)	%	Multiple (Cp x %)	Resultant Pollution Category
1	d	25,000	2	50,000	<b>X</b>
2	r	1	98	98	
<b>Sp</b>				<b>50,098</b>	

*Examples of determination of Ship Types for mixtures*

**Working Method**

*Step 1*

Identify Ship Type and the multiplication factor for each component using the IBC Code or the MEPC.2/Circular and table 2.

*Step 2*

Determine the concentration of each component and multiply the percentage by the factor found in step 1.

*Step 3*

Add multiples together and determine the resulting Ship Type, using the flowchart for determining Ship Types.

*Step 3a*

Apply the previously determined Pollution Category of the mixture if the added multiples are < 100.

**Example 1**

*Step 1*

Component 1 is Ship Type 1, the multiplication factor is 1,000

Component 2 is Ship Type 3, the multiplication factor is 10

Component 3 is Ship Type 3, the multiplication factor is 10

*Step 2*

Component 1 is 11% of the mixture

Multiple is 11,000

Component 2 is 40 % of the mixture

Multiple is 400

Component 3 is 49% of the mixture

Multiple is 490

*Step 3*

**$S_s = 11890$**

**$S_s \geq 10,000$**

**The ST 1 multiples are 11,000**

**The ST 1 multiples are  $\geq 10,000$**

**Therefore the Ship Type is 1**

*(Step 3a is not applicable since  $S_s > 100$ )*

Component number	Ship Type	Factor (f)	%	Multiples (f x %)	Pollution Category of mixture	Resultant Ship Type
1	1	1,000	11	11,000	Not applicable in this example	<b>1</b>
2	3	10	40	400		
3	3	10	49	490		
<b><math>S_s</math></b>				<b>11,890</b>		

**Example 2**

*Step 1*

Component 1 is Ship Type 2 and the multiplication factor is 100  
Component 2 is Ship Type 3 and the multiplication factor is 10

*Step 2*

Component 1 is 5% of the mixture, the multiple is 500  
Component 2 is 95% of the mixture, the multiple is 950

*Step 3*

**Ss = 1450**

**10,000 > Ss ≥ 1,000**

**Sum of ST 1 & 2 multiples is < 1,000**

**Therefore the Ship Type is 3**

*(Step 3a is not applicable since Ss > 100)*

Component number	Ship Type	Factor (f)	%	Multiples (f x %)	Pollution Category of mixture	Resultant Ship Type
1	2	100	5	500	Not applicable in this example	<b>3</b>
2	3	10	95	950		
<b>Ss</b>				<b>1,450</b>		

### Example 3

#### Step 1

Component 1 is Ship Type “ n/a” , the multiplication factor is 0  
 Component 2 is Ship Type 3, the multiplication factor is 10  
 Component 3 is diluent mineral oil, the multiplication factor is 10

#### Step 2

Component 1 is 10% of the mixture	Multiple is 0
Component 2 is 8% of the mixture	Multiple is 80
Component 3 is 82% of the mixture	Multiple is 820

#### Step 3

**Ss = 900**  
**1,000 > Ss ≥ 100**  
**Therefore the Ship Type is 3**  
*(Step 3a is not applicable since Ss > 100)*

Component number	Ship Type	Factor (f)	%	Multiples (f x %)	Pollution Category of mixture	Resultant Ship Type
1	N/a	0	10	0	Not applicable in this example	<b>3</b>
2	3	10	8	80		
3	Diluent mineral oil	10	82	820		
<b>Ss</b>				<b>900</b>		

**Example 4**

*Step 1*

Component 1 is Ship Type 2, the multiplication factor is 100  
Component 2 is Ship Type 3, the multiplication factor is 10  
Component 3 is unassessed, the multiplication factor is 100

*Step 2*

Component 1 is 4% of the mixture	Multiple is 400
Component 2 is 95% of the mixture	Multiple is 950
Component 3 is 1% of the mixture	Multiple is 100

*Step 3*

**Ss = 1,450**  
**10,000 < Ss ≥ 1,000**  
**Sum of ST 1 & 2 multiples is < 1,000**  
**Therefore the Ship Type is 3**  
*(Step 3a is not applicable since Ss > 100)*

Component number	Ship Type	Factor (f)	%	Multiples (f x %)	Pollution Category of mixture	Resultant Ship Type
1	2	100	4	400	Not applicable in this example	<b>3</b>
2	3	10	95	950		
3	Unassessed	100	1	100		
<b>Ss</b>				<b>1,450</b>		

**Example 5**

*Step 1*

Component 1 is Ship Type “n/a”, the multiplication factor is 0

Component 2 is Ship Type 3, the multiplication factor is 10

Component 3 is Ship Type 3, the multiplication factor is 10

*Step 2*

Component 1 is 91% of the mixture

Component 2 is 7% of the mixture

Component 3 is 2% of the mixture

Multiple is 0

Multiple is 70

Multiple is 20

*Step 3*

Ss = 90

Ss < 100

*Step 3a*

**Pollution Category of mixture is Y, as determined previously**

**Therefore the Ship Type is 3**

Component number	Ship Type	Factor (f)	%	Multiples (f x %)	Pollution Category of mixture	Resultant Ship Type
1	N/a	0	91	0	Y	3
2	3	10	7	70		
3	3	10	2	20		
<b>Ss</b>				<b>90</b>		

\*\*\*





**ANNEX 20****RESOLUTION MEPC.148(54)****Adopted on 24 March 2006****REVISED GUIDELINES FOR THE TRANSPORT OF VEGETABLE OILS IN DEEPTANKS OR IN INDEPENDENT TANKS SPECIALLY DESIGNED FOR THE CARRIAGE OF SUCH VEGETABLE OILS IN GENERAL DRY CARGO SHIPS**

THE MARINE ENVIRONMENT PROTECTION COMMITTEE,

RECALLING article 38(a) of the Convention on the International Maritime Organization concerning the function of the Committee conferred upon it by international conventions for the prevention and control of marine pollution,

RECALLING ALSO resolution MEPC.118(52) by which it adopted the revised Annex II of the International Convention for the Prevention of Pollution from Ships, 1973, as modified by the Protocol of 1978 relating thereto (hereinafter referred to as "MARPOL 73/78"),

RECALLING FURTHER resolution MEPC.119(52) by which it adopted amendments to the International Code for the Construction and Equipment of Ships Carrying Dangerous Chemicals in Bulk (IBC Code),

CONSIDERING that the Maritime Safety Committee, at its seventy-second session, considered and approved the proposed amendments to the IBC Code with a view to adoption under the provisions of the International Convention for the Safety of Life at Sea, 1974 (1974 SOLAS Convention),

RECOGNIZING the current practices for the transport of vegetable oils in deep tanks in general dry cargo ships,

RECOGNIZING ALSO the current practices of the transport of vegetable oils in independent tanks specially designed to carry these vegetable oils on board of general dry cargo ships,

NOTING the need for the continuation of the current mode of transport of these vegetable oils on specifically identified trades, where the lack of availability of NLS tankers is demonstrated,

BEING CONVINCED that adequate precaution is needed to provide the protection of the marine environment at the level as required by Annex II of MARPOL 73/78, as amended,

1. ADOPTS the revised Guidelines for the transport of vegetable oils in deep tanks or in independent tanks specially designed for the carriage of such vegetable oils in general dry cargo ships, the text of which is set out in the Annex to this resolution;
2. INVITES the Parties to note that the revised Guidelines supersede the Guidelines adopted by resolution MEPC.120(52) on 15 October 2004; and
3. INVITES ALSO the Parties to note that the revised Guidelines shall take effect on 1 January 2007.

**GUIDELINES FOR THE TRANSPORT OF VEGETABLE OILS IN DEEPTANKS  
OR IN INDEPENDENT TANKS SPECIALLY DESIGNED FOR THE CARRIAGE  
OF SUCH VEGETABLE OILS IN GENERAL DRY CARGO SHIPS**

**1 Preamble**

1.1 The Guidelines have been developed to allow general dry cargo ships, which are currently certified to carry vegetable oil in bulk, to continue to carry these vegetable oils on specific trades. These Guidelines only apply under the following conditions:

- .1 the vegetable oils are carried in deeptanks or independent tanks in general dry cargo ships specifically designed for the carriage of such oils under an NLS Certificate issued before 1 January 2007;
- .2 the products allowed to be carried are restricted to those unmodified vegetable oils (primarily triglycerides) which are listed in the IBC Code, identified by a footnote (k) in column *e*; and
- .3 the ship complies with all discharge requirements under Annex II to MARPOL 73/78.

1.2 The Guidelines have been developed in accordance with the provisions set forth in regulation 11.2 of Annex II to MARPOL 73/78 and in recognition of the need for standards, which provide an alternative to the International Code for the Construction and Equipment of Ship Carrying Dangerous Chemicals in Bulk.

**2 Carriage in deeptanks**

2.1 An Administration may grant a relaxation for the carriage requirements, as required by the IBC Code, when vegetable oils are carried in deeptanks in general dry cargo ships between States for which it is demonstrated that, as a result of their geographical location, the transport of vegetable oils from the exporting State to the receiving State would not be viable using NLS tankers as required by Annex II to MARPOL 73/78. This relaxation shall be endorsed on the ship's Certificate. Such relaxation shall be communicated to the IMO by the Administration.

2.2 Every general dry cargo ship, falling under paragraph 2 of the Guidelines, shall be subject to Annex II to MARPOL 73/78 regarding the discharge requirements and the carriage of a Manual and shall be certified to carry vegetable oils by means of the issue of a certificate under regulation 10.1 of that Annex.

2.3 Before granting a relaxation, the Administration shall receive a confirmation in writing that both the Government of the country of loading and the Government of the country of unloading concur with the proposed relaxation. These confirmations shall be retained on board.

### **3 Carriage in independent tanks**

3.1 An Administration may grant a relaxation for the carriage requirements as required by the IBC Code when vegetable oils are carried in independent tanks in general dry cargo ships specially designed for the carriage of these vegetable oils. This relaxation shall be endorsed on the ship's Certificate. Such relaxation shall be communicated to the IMO by the Administration.

3.2 The following criteria on construction and trade for such relaxation shall apply:

- .1 the independent tanks shall be situated at least 760 mm from the shell plating; and
- .2 such carriage of vegetable oils shall be restricted to specifically identified trades.

3.3 Every general dry cargo ship falling under paragraph 3 of the Guidelines shall be subject to Annex II to MARPOL 73/78 regarding the discharge requirements and the carriage of a Manual and shall be certified to carry vegetable oils by means of the issue of a certificate under regulation 10.1 of that Annex.

3.4 Before granting a relaxation, the Administration shall receive a confirmation in writing that both the Government of the country of loading and the Government of the country of unloading concur with the proposed relaxation. These confirmations shall be retained on board.

\*\*\*



## ANNEX 21

**ITEMS TO BE INCLUDED IN THE AGENDAS  
FOR MEPC 55, MEPC 56 AND MEPC 57**

<b>No.</b>	<b>Item</b>	<b>MEPC 55 October 2006</b>	<b>MEPC 56 July 2007</b>	<b>MEPC 57 March 2008</b>
1	Harmful aquatic organisms in ballast water	RG X	[RG] X	[RG] X
2	Recycling of ships	WG X	WG X	[WG] X
3	Prevention of air pollution from ships	WG X	WG X	[WG] X
4	Consideration and adoption of amendments to mandatory instruments	DG X	[X]	[X]
5	Interpretations and amendments to MARPOL 73/78 and related instruments	X	X	X
6	Implementation of the OPRC Convention and the OPRC-HNS Protocol and relevant Conference resolutions	X	X	X
7	Identification and protection of Special Areas and PSSAs	X	X	X
8	Inadequacy of reception facilities	X	X	X
9	Reports of sub-committees	X	X	X
10	Work of other bodies	X	X	X
11	Status of Conventions	X	X	X
12	Harmful anti-fouling systems for ships	X	[X]	[X]

No.	Item	MEPC 55 October 2006	MEPC 56 July 2007	MEPC 57 March 2008
13	Promotion of implementation and enforcement of MARPOL 73/78 and related instruments	X	X	X
14	Follow-up to UNCED and WSSD	X	[X]	[X]
15	Technical co-operation programme	X	X	X
16	Role of the human element	X	[WG] X	[X]
17	Formal safety assessment	X	X	[X]
18	Work programme of the Committee and subsidiary bodies	X	X	X
19	Application of the Committees' Guidelines	X	[X]	[X]
20	Election of the Chairman and Vice-Chairman	X	X	
21	Any other business	X	X	X